



Advanced Computer Systems



*Instrument Processing Facility L1b*

Doc. No.: *CS-RS-ACS-GS-5123*  
Issue: *1.0*  
Date: *31 January 2004*  
Page: *1*

---

## **CRYOSAT Ground Segment**

### **Instrument Processing Facility L1b**

## **L2 Products Format Specification**

### **[L2-FMT]**

---

**CS-RS-ACS-GS-5123**

**Issue: 1.0**

**Date: 31/01/2004**

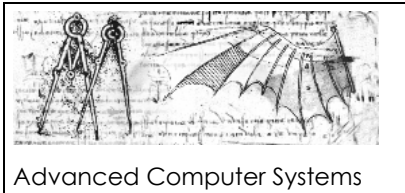

## Document Signature Table

APPROVAL TABLE		
Date		
Name	Function	Signature
C. ZELLI	ACS Project Manager	
P. VIAU	ESA Project Manager	
G. RATIER	Cryosat Project Manager	

CONTRACTOR TABLE				
	Name	Function	Signature	Date
<b>Author</b>	ACS team			
<b>Verification</b>	C. ZELLI	IPF1 Project Manager		
<b>Quality Assurance</b>	O.GUERRA	Quality Manager		
<b>Approval</b>	R.MEDRI	EOD Manager		

## Distribution List

Internal Distribution	
Name	No. Copies
N. Vacca	1
T. Geminale	1
M. Antonacci	1
F. Carriero	1
P. Mantovani	1
V. Spaventa	1
A. Vollono	1
R.Medri	1

External Distribution		
Company	Name	No. Copies
ESA	P. Viau	1
MSSL	S. Baker	1

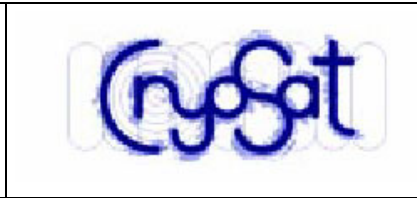
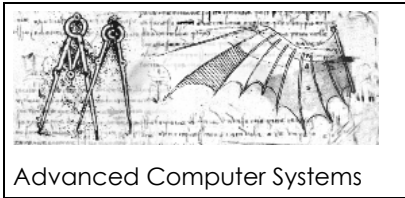

*Instrument Processing Facility L1b*

Doc. No.: *CS-RS-ACS-GS-5123*  
Issue: *1.0*  
Date: *31 January 2004*  
Page: *3*

## Document Change Record

<b>Issue/Rev.</b>	<b>Class (R=Review /A=Approval)</b>	<b>Date</b>	<b>Reason for Change</b>	<b>Changed Pages/Paragraphs</b>
1.0	R	31/01/2004	Initial Issue for IPF2 Vb	all

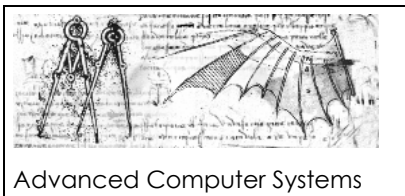

*Instrument Processing Facility L1b*

Doc. No.: CS-RS-ACS-GS-5123  
 Issue: 1.0  
 Date: 31 January 2004  
 Page: 4

## TABLE OF CONTENTS

<b>1</b>	<b>INTRODUCTION .....</b>	<b>5</b>
1.1	PURPOSE AND SCOPE .....	5
1.2	DOCUMENT STRUCTURE.....	5
1.3	APPLICABLE & REFERENCE DOCUMENTS .....	6
1.3.1	<i>Applicable Documents.....</i>	<i>6</i>
1.3.2	<i>Reference Documents.....</i>	<i>6</i>
1.4	ACRONYMS AND ABBREVIATIONS .....	7
<b>2</b>	<b>LEVEL-2 GENERAL FORMAT DESCRIPTION .....</b>	<b>8</b>
2.1	FILE STRUCTURE .....	9
2.2	XML HEADER FILE .....	10
2.2.1	<i>Fixed Header (Cryosat Header).....</i>	<i>10</i>
2.2.2	<i>Variable Header (Product Header).....</i>	<i>11</i>
2.2.2.1	XML Main Product Header (XML MPH).....	11
2.2.2.2	XML Specific Product Header (XML SPH) .....	14
2.3	PRODUCT FILES.....	19
2.3.1	<i>Main Product Header (MPH) .....</i>	<i>20</i>
2.3.2	<i>Specific Product Header (SPH).....</i>	<i>27</i>
2.3.3	<i>Measurement Data Set Record (MDS).....</i>	<i>36</i>
<b>3</b>	<b>CRYOSAT LEVEL-2 PRODUCTS NAMING .....</b>	<b>37</b>

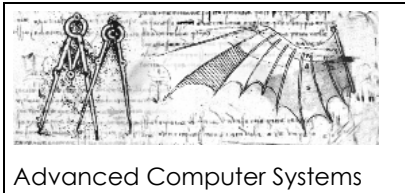

Advanced Computer Systems



*Instrument Processing Facility L1b*

Doc. No.: *CS-RS-ACS-GS-5123*  
Issue: *1.0*  
Date: *31 January 2004*  
Page: *5*

# 1 INTRODUCTION

This document contains the description of the format of the Level-2 products generated inside the PDS for the Cryosat mission.

## 1.1 PURPOSE AND SCOPE

The purpose of the document is to define the product structure and the content of the Level-2 file generated in the PDS identifying for each data section and field the meaning and the format to be used for its representation.

## 1.2 DOCUMENT STRUCTURE

The document includes the following sections:

Section 1 - Introduction

The present section.

Section 2 - Level-2 General Format Description

This section gives the general description of the Level-2 products in terms of common organisation and format and the detailed description of the format for each file type.

Section 3 - Cryosat Level-2 Products

This section contains the product file name and the composition rules of the file name.

 <p>Advanced Computer Systems</p>		<p><i>Instrument Processing Facility L1b</i></p> <p>Doc. No.: CS-RS-ACS-GS-5123  Issue: 1.0  Date: 31 January 2004  Page: 6</p>
---	---	---

## 1.3 APPLICABLE & REFERENCE DOCUMENTS

### 1.3.1 Applicable Documents

Document Title	Identifier	Reference
Earth Explorer Ground Segment File Format Standard Issue 1.4 , 13 June 2003	CS-TN-ESA-GS-0154	[FMT-GUIDE]

### 1.3.2 Reference Documents

Document Title	Identifier	Reference
IPF2 Processors Architecture Description Issue 1.0, 20 November 2003	CS-TN-ACS-GS-5120	[IPF2-TN]
Cryosat IPF2 ESL Input & Output Definition Document Issue 1.0, 11 December 2003	CS-IS-MSL-GS-2001	[L2-IODD]
IPF1 Product Formats Specification Issue 2.6, 31 January 2004	CS-RS-ACS-GS-5106	[L1-FMT]
Level 0 Products Specification Format Issue 1.5, 31 January 2003	CS-ID-ACS-GS-0119	[L0-FMT]
IEEE Standard for Binary Floating-Point Arithmetic. ANSI/IEEE Std 754-1985 Institute of Electrical and Electronics Engineers Issued 1985	IEEE-754	[IEEE]
Extensible Markup Language (XML) 1.0 (Second Edition) W3C Recommendation 6 October 2000	<a href="http://www.w3.org/TR/2000/REC-xml-20001006">http://www.w3.org/TR/2000/REC-xml-20001006</a>	[XML-GUIDE]
XML Schema Definition Language: W3C XML Schema Working Group and Schema Specifications	<a href="http://www.oasis-open.org/cover/schemas.html#W3CWorkingGroup">http://www.oasis-open.org/cover/schemas.html#W3CWorkingGroup</a>	[XML-SCHEMA]

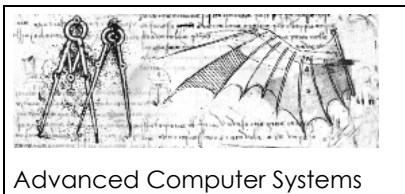

Advanced Computer Systems



*Instrument Processing Facility L1b*

Doc. No.: *CS-RS-ACS-GS-5123*  
Issue: *1.0*  
Date: *31 January 2004*  
Page: *7*

## 1.4 ACRONYMS AND ABBREVIATIONS

<b>ACS</b>	Advanced Computer Systems S.p.A.
<b>AGC</b>	Automatic Gain Control
<b>AIR</b>	Azimuth Impulse Response
<b>AISP</b>	Annotated Instrument Source Packet
<b>APID</b>	Application Process IDentifier
<b>BER</b>	Bit Error Rate
<b>BLOB</b>	Binary Large Object
<b>CADU</b>	Channel Access Data Unit
<b>CAL</b>	Calibration
<b>CCSDS</b>	Consultative Committee for Space Data Systems
<b>CVCDU</b>	Coded Virtual Channel Data Unit
<b>DSR</b>	Data Set Record
<b>EO</b>	Earth Observation
<b>ESA</b>	European Space Agency
<b>FOS</b>	Flight Operations Segment
<b>FBR</b>	Full Bit Rate
<b>G/S</b>	Ground Segment
<b>HK/TM</b>	Housekeeping/Telemetry data
<b>ID</b>	IDentifier
<b>I/O</b>	Input/Output
<b>ISP</b>	Instrument Source Packet
<b>L1B</b>	Level 1B
<b>LRM</b>	Low Rate Mode
<b>MDS</b>	Measurement Data Set
<b>MJD</b>	Modified Julian Day
<b>MON</b>	Monitoring
<b>MPH</b>	Main Product Header
<b>PDS</b>	Payload Data Segment
<b>PSLR</b>	Peak to Side Lobe Ratio
<b>PSS-05</b>	ESA Software Engineering Standard
<b>rc</b>	Radar Cycle
<b>RIR</b>	Range Impulse Response
<b>SIRAL</b>	Synthetic Interferometric Radar ALtimeter
<b>SOW</b>	Statement Of Work
<b>SPH</b>	Specific Product Header
<b>TAI</b>	International Atomic Time Reference
<b>TBC</b>	To Be Clarified
<b>TBD</b>	To Be Defined
<b>TT&amp;C</b>	Tracking, Telemetry and Command
<b>UTC</b>	Universal Time Co-ordinates
<b>VCID</b>	Virtual Channel IDentifier
<b>VCDU</b>	Virtual Channel Data Unit
<b>WGS84</b>	World Geodetic System 1984
<b>XML</b>	eXtensible Markup Language



Advanced Computer Systems



*Instrument Processing Facility L1b*

Doc. No.: *CS-RS-ACS-GS-5123*  
Issue: *1.0*  
Date: *31 January 2004*  
Page: *8*

## **2 LEVEL-2 GENERAL FORMAT DESCRIPTION**

The Level-2 products are derived from the Cryosat L1B products generated by the IPF1 and relevant to the science modes, that is LRM – SAR – SARIN.

Differently from the L1B products, a common layout (i.e. independent of the SIRAL operative mode) is defined for the Level 2 products.

As described in [IPF2-TN] a L2 product is generated soon after a L1B product is available thus resembling still a data driven approach. This implies that following this first generation step there will be L2 products still separated by modes (specifically LRM – SAR – SARin) defined over the same time window of the input L1B.

In the second step, a global L2 product is generated from the L2 mode dependent products collected over an entire orbit, specifically from ANX to ANX. This second step most likely does not imply any specific processing, but simply a concatenation of files in chronological order. L2 products from the first step, in fact, regardless of their SIRAL mode dependence, have binary records with the same layout.

## 2.1 FILE STRUCTURE

The file structure of any file produced by the IPF2 system must follow the requirements of the [FMT-GUIDE] .

Each level-2 product is composed by two files:

- XML Header File
- Product File

The XML Header file is an auxiliary ASCII file that users can easily access for identifying the product without needs to look inside the Product File.

The Product File is the real product containing meaningful instrument's data and ASCII header used by ad hoc developed standard tools for inspecting the product's content. In order to use tools already developed for the ENVISAT mission, the product structure for Cryosat will follow the correspondent one of the ENVISAT products as far as possible.

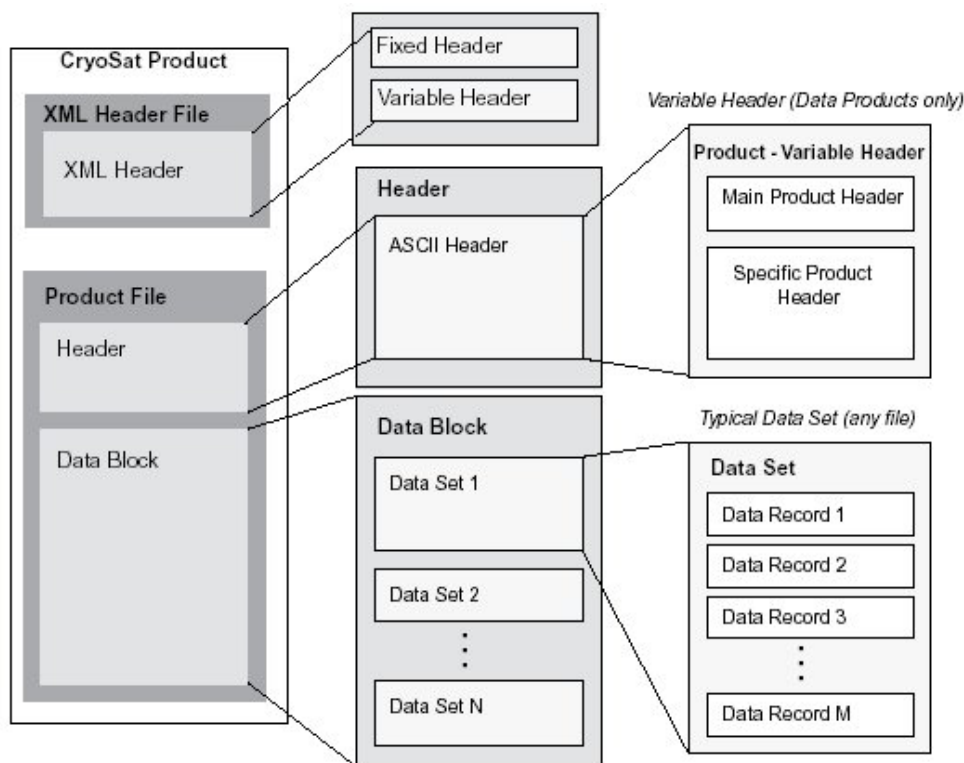



Advanced Computer Systems



*Instrument Processing Facility L1b*

Doc. No.: *CS-RS-ACS-GS-5123*  
Issue: *1.0*  
Date: *31 January 2004*  
Page: *10*

## **2.2 XML HEADER FILE**

The XML Header file contains information identifying the product and easy to read as based on a standard syntax accessed by common tools available for visualising its content. The XML syntax has been chosen for the scope of the PDS.

The XML Header file is composed by:

- a Fixed Header
- a Variable Header

The Fixed Header (hereafter called Standard Cryosat Header) is the common header for all files managed into the PDS. That means it is applied to all files flowing amongst the sub-systems composing the PDS.

The Variable Header (hereafter called Product Header) is the header with format and content depending on the file type and kind of product.

### **2.2.1 Fixed Header (Cryosat Header)**

The Standard Cryosat Header is completely ASCII and based on XML syntax and conventions proposed in [FMT-GUIDE].

The format and content of the Standard Cryosat Header is under ESA responsibility and it is specified in [FMT-GUIDE].

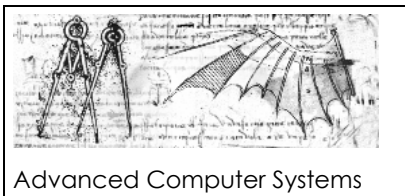

## 2.2.2 Variable Header (Product Header)

The Variable Header (hereafter called Product Header) for the Level 1 product is composed by:

- a XML Main Product Header (XML MPH)
- a XML Specific Product Header (XML SPH) which includes Reference Data Set Descriptors for external input files or more XML Specific Measurement Data Header (XML MDH) for the Data Sets of the Product

The XML MPH and XML SPH are derived from the correspondent headers (MPH and SPH) of the Product File, removing the unused fields and fields already reported in the Standard Cryosat Header.

Each header is completely ASCII and based on XML syntax and conventions proposed in the [FMT-GUIDE].

The following paragraphs describe the format and content of the XML MPH and XML SPH without overload of the XML format description.

### 2.2.2.1 XML Main Product Header (XML MPH)

Field #	Description	Units	Bytes	Format
	MPH	Tag		
	<i>Product Identification Info</i>			
<b>#01</b>	Product	Tag		
	Product File Name Note: the file name shall be without extension		62	See Section 3
<b>#02</b>	Proc_Stage_Code	Tag		
	Processing stage code identifier: RPR0 = Reprocessing OFFL = Routine Operations NRT_ = Near Real Time TEST = Test		4	4*uc
<b>#03</b>	Ref_Doc	Tag		
	Reference DFCB Document describing the product		23	CS-RS-ACS-GS-5106
	<i>Data Processing Information</i>			
<b>#04</b>	Proc_Time	Tag		



Advanced Computer Systems



Instrument Processing Facility L1b

Doc. No.: CS-RS-ACS-GS-5123  
 Issue: 1.0  
 Date: 31 January 2004  
 Page: 12

	Processing Time (Product Generation Time)		30	UTC=yyyy-mm-ddThh:mm:ss.uuuuuu
<b>#05</b>	Software_Version	Tag		
	Processor Name and software version number.		14	ProcessorName/VV.rr
<i>Orbit Information</i>				
<b>#06</b>	Phase	Tag		
	Phase Code: If not used set to X		1	uc
<b>#07</b>	Cycle	Tag		
	Cycle number. If not used set to +000		4	%+04d
<b>#08</b>	Rel_Orbit	Tag		
	Relative Orbit Number at sensing start time. If not used set to +00000		6	%+06d
<b>#09</b>	Abs_Orbit	Tag		
	Absolute Orbit Number at sensing start time. If not used set to +00000		6	%+06d
<b>#10</b>	State_Vector_Time	Tag		
	UTC state vector time		30	UTC=yyyy-mm-ddThh:mm:ss.uuuuuu
<b>#11</b>	Delta_UT1	Tag		
	Universal Time Correction: DUT1 = UT1 – UTC If not used set to +.000000	s	8	%+08.6f
<b>#12</b>	X_Position	Tag		
	X position in Earth Fixed Reference If not used set to +0000000.000	m	12	%+012.3f
<b>#13</b>	Y_Position	Tag		
	Y position in Earth Fixed Reference If not used set to +0000000.000	m	12	%+012.3f
<b>#14</b>	Z_Position	Tag		
	Z position in Earth Fixed Reference If not used set to +0000000.000	m	12	%+012.3f
<b>#15</b>	X_Velocity	Tag		
	X velocity in Earth Fixed Reference If not used set to +0000.000000	m/s	12	%+012.6f
<b>#16</b>	Y_Velocity	Tag		
	Y velocity in Earth Fixed Reference If not used set to +0000.000000	m/s	12	%+012.6f

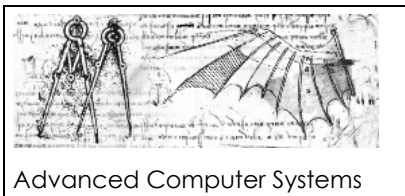

<b>#17</b>	Z_Velocity	Tag		
	Z velocity in Earth Fixed Reference If not used set to +0000.000000	m/s	12	%+012.6f
<b>#18</b>	State_Vector_Source	Tag		
	Source of Orbit State Vector Record  FP = FOS predicted DN = DORIS Level 0 navigator DP = DORIS precise orbit FR= FOS Restituted DI = DORIS Preliminary		2	2*uc
<i>Product Confidence Data Information</i>				
<b>#19</b>	Product_Err	Tag		
	Product Error Flag  1 errors have been reported in the Product  0 no erros		1	uc
<i>Product Size Information</i>				
<b>#20</b>	Tot_Size	Tag		
	Total Size of the Data Product	bytes	21	%021d

**Table 2.2.2.1-1: XML Main Product Header Description**

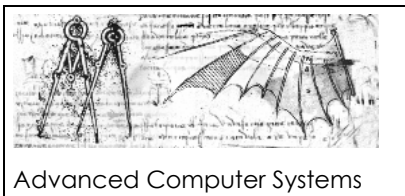

### 2.2.2.2 XML Specific Product Header (XML SPH)

Field #	Description	Units	Bytes	FORMAT
	SPH	tag		
<i>Product description and identification</i>				
<b>#1</b>	SPH_Descriptor	tag		
	Name describing the Specific Product Header		28	<i>ProductID Specific Header See Table 3-1</i>
<i>Product Time information</i>				
	Time_Information	tag		
<b>#2</b>	Start_Record_Time	tag		
	TAI of the first record in the Main MDS of this product		30	TAI=yyyy-mm-ddThh:mm:ss.uuuuuu
<b>#3</b>	Stop_Record_Time	tag		
	TAI of the last record in in the Main MDS of this product		30	TAI=yyyy-mm-ddThh:mm:ss.uuuuuu
<i>Product Orbit information</i>				
	Orbit_Information	Tag		
<b>#4</b>	ABS_Orbit_Start	Tag		
	Absolute Orbit Number at sensing start time.		6	%06d
<b>#5</b>	Rel_Time_ASC_Node_Start	Tag		
	Relative time since crossing ascending node time relative to start time of data sensing.	s	11	%011.6f
<b>#6</b>	ABS_Orbit_Stop	Tag		
	Absolute Orbit Number at sensing stop time.		6	%06d



<b>#7</b>	Rel_Time_ASC_Node_Stop	Tag		
	Time of the ascending node relative to stop time of data sensing. Relative time since crossing ascending node time relative to stop time of data sensing.	s	11	%011.6f
<b>#8</b>	Equator_Cross_Time	Tag		
	Time of equator crossing at the ascending node relative to the sensing start time.		30	UTC=yyyy-mm-ddThh:mm:ss.uuuuuu
<b>#9</b>	Equator_Cross_Long	Tag		
	Longitude of equator crossing at the ascending node relative to the sensing start time (positive East, 0 = Greenwich) referred to WGS84.	10-6 deg	11	%+011d
<b>#10</b>	Ascending_Flag	Tag		
	Orbit Orientation at the sensing start time A=Ascending D=Descending		1	uc
<i>Product Location Information</i>				
	Product_Location	tag		
<b>#11</b>	Start_Lat	tag		
	WGS84 latitude of the first record in the Main MDS (positive north)	10-6 deg	11	%+011d
<b>#12</b>	Start_Long	tag		
	WGS84 longitude of the first record in the Main MDS (positive East, 0 = Greenwich)	10-6 deg	11	%+011d
<b>#13</b>	Stop_Lat	tag		
	WGS84 latitude of the last record in the Main MDS (positive north)	10-6 deg	11	%+011d



Advanced Computer Systems



Instrument Processing Facility L1b

Doc. No.: CS-RS-ACS-GS-5123  
 Issue: 1.0  
 Date: 31 January 2004  
 Page: 16

<b>#14</b>	Stop_Long	tag		
	WGS84 longitude of the last record in the Main MDS (positive East, 0 = Greenwich)	10-6 deg	11	%+011d
<i>SIRAL Level 1B Quality information</i>				
	Level_1_Confidence_Data	tag		
<b>#15</b>	L1_Proc_Flag	tag		
	Processing errors significance flag			
	1 errors (percentage of errors greater than threshold)		1	uc
	0 no erros			
<b>#16</b>	L1_Processing_Quality	tag		
	Percentage of quality checks successfully passed during the SP processing (max allowed +10000)	10-2 %	6	%+06d
<b>#17</b>	L1_Proc_Thresh	tag		
	Minimum acceptable percentage of quality threshold that must be passed during SP processing (max allowed +10000)	10-2 %	6	%+06d
<b>#18</b>	Num_L1_DSR_PROC	tag		
	Number of L1 Data Set Records analysed		11	%+011d
<i>SIRAL Mode Statistics</i>				
	SIR_Mode_Statistics	tag		
<b>#19</b>	LRM_Mode_Percent	tag		
	Percentage of input Level 1B records detected in LRM mode	10-2 %	6	%+06d
<b>#20</b>	SAR_Mode_Percent	tag		
	Percentage of input Level 1B records detected in SAR mode	10-2 %	6	%+06d
<b>#21</b>	SARIN_Mode_Percent	tag		
	Percentage of input Level 1B records detected in SARIN mode	10-2 %	6	%+06d



<b>#22</b>	Other_Modes_Percent	tag		
	Percentage of input Level 1B records detected in other modes	10-2 %	6	%+06d
<i>SIRAL Level 2 Processing information</i>				
	Level_2_Confidence_Data	tag		
<b>#23</b>	L2_Prod_Status	tag		
	Complete/Incomplete Product Completion Flag (0 or 1).  1 if the Product as a duration shorter than the input Level 0		1	uc
<b>#24</b>	L2_Proc_Flag	tag		
	Processing errors significance flag 1 errors (percentage of errors greater than threshold) 0 no erros		1	uc
<b>#25</b>	L2_Processing_Quality	tag		
	Percentage of quality checks successfully passed during Level 1B processing (max allowed +10000)	10-2 %	6	%+06d
<b>#26</b>	L2_Proc_Thresh	tag		
	Minimum acceptable percentage of quality threshold that must be passed during Level 1B processing (max allowed +10000)	10-2 %	6	%+06d
<i>Data Set Descriptors</i>				
	DSDs	tag		
	List_of_DSDs	tag		
	Data_Set_Descriptor	tag		
<b>#27</b>	Data_Set_Name	tag		
	Name of the Data Set		28	uc
<b>#28</b>	Data_Set_Type	tag		
	M for Measurement – R for Reference		1	uc
<b>#29</b>	File_Name	tag		
	Name of the reference file. Field is left empty for Measurement DSD		62	uc
<b>#30</b>	Data_Set_Offset	tag		

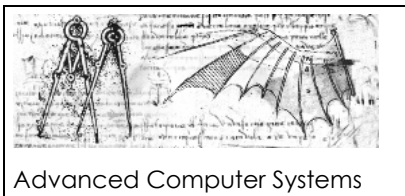

	Offset in bytes from the beginning of the DBL file. For reference DSDs the field is set to 0.	bytes	21	%+021d
<b>#31</b>	Data_Set_Size	tag		
	Size in bytes of the Measurement Data Set Record. For reference DSDs the field is set to 0.	bytes	21	%+021d
<b>#32</b>	Num_of_Records	tag		
	Number of Data Set Records. For reference DSDs the field is set to 0.		11	%+011d
<b>#33</b>	Record_Size	tag		
	Record size in bytes. For reference DSDs the field is set to 0.	bytes	11	%+011d
<b>#34</b>	Byte_Order	tag		
	It describes the endianness of the data set 3210 → Big-endian 0123 → Little-endian  For Reference DSDs the field is left empty		4	%4c  3210 for Cryosat

**Table 2.2.2.2-1: XML Specific Product Header description**

## 2.3 PRODUCT FILES

The Product File structure will follow the one defined for the ENVISAT level-0 products as much as possible.

As shown in figure 2.3-1, each product file is composed by:

- Main Product Header (MPH)
- Specific Product Header (SPH)
- Data Sets

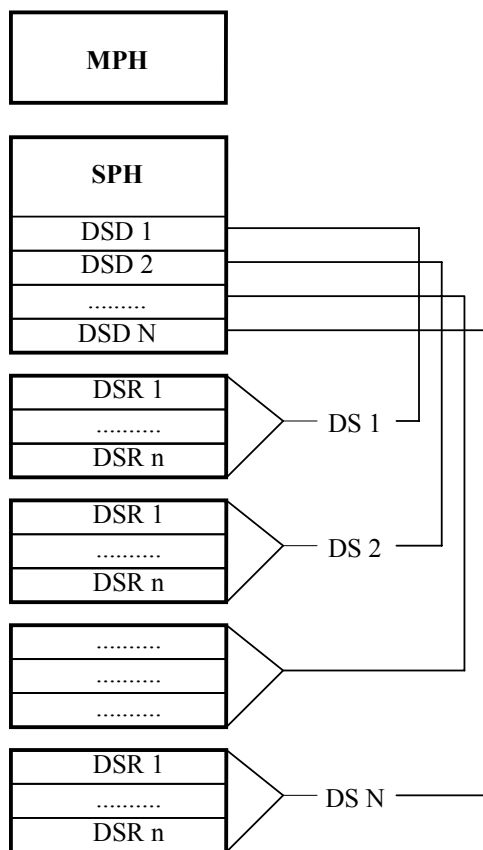

**Figure 2.3-1: Generalised Product Structure**

The MPH and SPH blocks are ASCII and following the current syntax for any composing field:

**FieldName= value<units>**

The Data Sets are completely binary and contains one or more Data Set Records each. According to the following Products definitions the maximum number of DS in a product is two.



### 2.3.1 Main Product Header (MPH)

Field #	Description	Units	Bytes	Format
<i>Product Identification Info</i>				
<b>#01</b>	<b>PRODUCT=</b>	keyword	8	
	quotation mark (")		1	uc
	Product File Name It is left justified with trailer blanks		62	See 3.1
	quotation mark (")		1	uc
	newline character	terminator	1	
<b>#02</b>	<b>PROC_STAGE=</b>	keyword	11	11*uc
	Processing stage code: N = Near-Real Time T = Test O = OFF Line (Systematic) R = Reprocessing		1	
	newline character	terminator	1	
<b>#03</b>	<b>REF_DOC=</b>	keyword	8	8*uc
	quotation mark (")		1	uc
	Reference DFCB Document describing the product		23	23*uc
	quotation mark (")		1	uc
	newline character	terminator	1	
<b>#04</b>	<b>Spare</b> (blank characters)		40	40*uc
	newline character	terminator	1	uc
<i>Data Processing Information</i>				
<b>#05</b>	<b>ACQUISITION_STATION=</b>	keyword	20	20*uc
	quotation mark (")		1	uc
	Acquisition Station ID Filled by blanks		20	Kiruna
	quotation mark (")		1	uc
	newline character	terminator	1	
<b>#06</b>	<b>PROC_CENTER=</b>	keyword	12	12*uc
	quotation mark (")		1	uc
	Processing Center ID code		6	PDS
	quotation mark (")		1	uc
	newline character	terminator	1	



Advanced Computer Systems



Instrument Processing Facility L1b

Doc. No.: CS-RS-ACS-GS-5123  
 Issue: 1.0  
 Date: 31 January 2004  
 Page: 21

<b>#07</b>	<b>PROC_TIME=</b>	keyword	10	10*uc
	quotation mark (")		1	uc
	Processing Time (Product Generation Time)	UTC	27	dd-MMM-yyyy hh:mm:ss.uuuuuu
	quotation mark (")		1	uc
	newline character	terminator	1	
<b>#08</b>	<b>SOFTWARE_VER=</b>	keyword	13	13*uc
	quotation mark (")		1	uc
	Processor name, up to 8 characters, and software version number followed by trailer blanks if any. If not used set to blanks		14	14*uc ProcessorName/VV.rr
	quotation mark (")		1	uc
	newline character	terminator	1	
<b>#09</b>	<b>Spare</b> (blank characters)		40	40*uc
	newline character	terminator	1	uc
<i>Information on Time of Data</i>				
<b>#10</b>	<b>SENSING_START=</b>	keyword	14	14*uc
	quotation mark (")		1	uc
	UTC start time of data sensing. This is the UTC start time of the Input Level 1B/L2 Product. If not used set to 27 blanks	UTC	27	dd-MMM-yyyy hh:mm:ss.uuuuuu
	quotation mark (")		1	uc
	newline character	terminator	1	
<b>#11</b>	<b>SENSING_STOP=</b>	keyword	13	13*uc
	quotation mark (")		1	uc
	UTC stop time of data sensing. This is the UTC stop time of the Input Level 1B/L2 Product. If not used set to 27 blanks	UTC	27	dd-MMM-yyyy hh:mm:ss.uuuuuu
	quotation mark (")		1	uc
	newline character	terminator	1	
<b>#12</b>	<b>Spare</b> (blank characters)		40	40*uc
	newline character	terminator	1	uc
<i>Orbit Information</i>				
<b>#13</b>	<b>PHASE=</b>	keyword	6	6*uc
	Phase Code: phase letter (A, B, ...) If not used set to X		1	
	newline character	terminator	1	uc



<b>#14</b>	<b>CYCLE=</b>	keyword	6	6*uc
	Cycle number. If not used set to +000		4	%+04d
	newline character	terminator	1	uc
<b>#15</b>	<b>REL_ORBIT=</b>	keyword	10	10*uc
	Relative Orbit Number at sensing start time. If not used set to +00000		6	%+06d
	newline character	terminator	1	uc
<b>#16</b>	<b>ABS_ORBIT=</b>	keyword	10	10*uc
	Absolute Orbit Number at sensing start time. If not used set to +00000		6	%+06d
	newline character	terminator	1	uc
<b>#17</b>	<b>STATE_VECTOR_TIME=</b>	keyword	18	18*uc
	quotation mark (")		1	uc
	UTC state vector time It is filled properly in case of usage of FOS Predicted Orbit information otherwise it shall be set to 27 blanks	UTC	27	dd-MMM-yyyy hh:mm:ss.uuuuuu
	quotation mark (")		1	uc
	newline character	terminator	1	
<b>#18</b>	<b>DELTA_UT1=</b>	keyword	10	10*uc
	Universal Time Correction: DUT1 = UT1 – UTC Not used for Cryosat. It shall be set to +.000000	s	8	%+08.6f
	<s>	units	3	3*uc
	newline character	terminator	1	
<b>#19</b>	<b>X_POSITION=</b>	keyword	11	11*uc
	X position in Earth Fixed Reference. If not used set to +0000000.000	m	12	%+012.3f
	<m>	units	3	3*uc
	newline character	terminator	1	
<b>#20</b>	<b>Y_POSITION=</b>	keyword	11	11*uc
	Y position in Earth Fixed Reference. If not used set to +0000000.000	m	12	%+012.3f
	<m>	units	3	3*uc
	newline character	terminator	1	



<b>#21</b>	<b>Z_POSITION=</b>	keyword	11	11*uc
	Z position in Earth Fixed Reference. If not used set to +0000000.000	m	12	%+012.3f
	<m>	units	3	3*uc
	newline character	terminator	1	
<b>#22</b>	<b>X_VELOCITY=</b>	keyword	11	11*uc
	X velocity in Earth Fixed Reference. If not used set to +0000.000000	m/s	12	%+012.6f
	<m/s>	units	5	5*uc
	newline character	terminator	1	
<b>#23</b>	<b>Y_VELOCITY=</b>	keyword	11	11*uc
	Y velocity in Earth Fixed Reference. If not used set to +0000.000000	m/s	12	%+012.6f
	<m/s>	units	5	5*uc
	newline character	terminator	1	
<b>#24</b>	<b>Z_VELOCITY=</b>	keyword	11	11*uc
	Z velocity in Earth Fixed Reference. If not used set to +0000.000000	m/s	12	%+012.6f
	<m/s>	units	5	5*uc
	newline character	terminator	1	
<b>#25</b>	<b>VECTOR_SOURCE=</b>	keyword	14	14*uc
	quotation mark (")		1	uc
	Source of Orbit State Vector Record FP = FOS predicted DN = DORIS Level 0 navigator DP = DORIS precise orbit FR = FOS Restituted DI = DORIS Preliminary		2	2*uc
	quotation mark (")		1	uc
	newline character	terminator	1	
<b>#26</b>	<b>Spare</b> (blank characters)		40	40*uc
	newline character	terminator	1	uc
<i>SBT to UTC conversion Information</i>				
<b>#27</b>	<b>UTC_SBT_TIME=</b>	keyword	13	13*uc
	quotation mark (")		1	uc



	Not used and set to 27 blanks		27	\$
	quotation mark (")		1	uc
	newline character	terminator	1	uc
<b>#28</b>	<b>SAT_BINARY_TIME=</b>	keyword	16	16*uc
	Satellite Binary Time Not used for Cryosat and it shall be set to zeros		11	+0000000000
	newline character	terminator	1	uc
<b>#29</b>	<b>CLOCK_STEP =</b>	keyword	11	11*uc
	Clock Step Not used for Cryosat and it shall be set to zeros		11	+0000000000
	<ps>	units	4	4*uc
	newline character	terminator	1	uc
<b>#30</b>	<b>Spare</b> (blank characters)		32	32*uc
	newline character	terminator	1	uc
<i>Leap Second Information</i>				
<b>#31</b>	<b>LEAP.UTC=</b>	keyword	9	9*uc
	quotation mark (")		1	uc
	UTC Time of the occurrence of the leap second. If a leap second occurred in the product window the field is set by a devoted function in the CFI EXPLORER_ORBIT library (see [EXPL_ORB-SUM] for details), otherwise it is set to 27 blanks. It corresponds to the time after the Leap Second occurrence (i.e. midnight of the day after the leap second)		27	dd-MMM-yyyy hh:mm:ss.uuuuuu
	quotation mark (")		1	uc
	newline character	terminator	1	uc
<b>#32</b>	<b>LEAP_SIGN=</b>	keyword	10	10*uc
	Leap second sign If a leap second occurred in the product window the field is set to the expected value by a devoted function in the CFI EXPLORER_ORBIT library (see [EXPL_ORB-SUM] for details), otherwise it is set to +000.	s	4	%+04d
	newline character	terminator	1	uc
<b>#33</b>	<b>LEAP_ERR=</b>	keyword	9	9*uc



Advanced Computer Systems



Instrument Processing Facility L1b

Doc. No.: CS-RS-ACS-GS-5123  
 Issue: 1.0  
 Date: 31 January 2004  
 Page: 25

	Leap second error flag.  This field is always set to 0 considering that CRYOSAT products have true UTC times		1	uc
	newline character	terminator	1	uc
<b>#34</b>	<b>Spare</b> (blank characters)		40	40*uc
	newline character	terminator	1	uc
<i>Product Confidence Data Information</i>				
<b>#35</b>	<b>PRODUCT_ERR=</b>	keyword	12	12*uc
	Product Error Flag set to 1 if errors have been reported in the product		1	uc
	newline character	terminator	1	uc
<i>Product Size Information</i>				
<b>#36</b>	<b>TOT_SIZE=</b>	keyword	9	9*uc
	Total size of the product	bytes	21	%+021d
	<bytes>	units	7	7*uc
	newline character	terminator	1	Uc
<b>#37</b>	<b>SPH_SIZE=</b>	keyword	9	9*uc
	Length of the SPH	bytes	11	%+011d
	<bytes>	units	7	7*uc
	newline character	terminator	1	Uc
<b>#38</b>	<b>NUM_DSD=</b>	keyword	8	8*uc
	Number of Data Set Descriptors, including spares and all other types of DSDs		11	%+011d
	newline character	terminator	1	Uc
<b>#39</b>	<b>DSD_SIZE=</b>	keyword	9	9*uc
	Length of each DSD	bytes	11	%+011d
	<bytes>	units	7	7*uc
	newline character	terminator	1	Uc
<b>#40</b>	<b>NUM_DATA_SETS=</b>	keyword	14	14*uc
	Number of attached Data Sets (note that not all the DSDs have a DS attached)		11	%+011d
	newline character	terminator	1	Uc
<b>#41</b>	<b>CRC=</b>	keyword	4	4*uc
	Cyclic Redundancy Code computed as overall value of all records of the Measurement Data Set. If not computed it shall be set to -00001		6	%+06d
	newline character	terminator	1	Uc

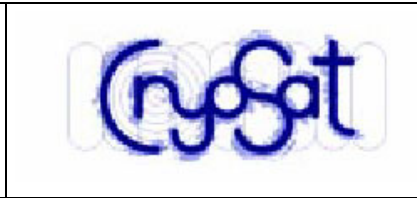
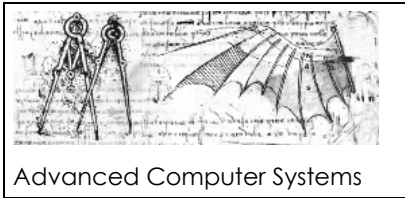

*Instrument Processing Facility L1b*

Doc. No.: *CS-RS-ACS-GS-5123*  
 Issue: *1.0*  
 Date: *31 January 2004*  
 Page: *26*

<b>#42</b>	<b>Spare</b> (blank characters)		29	29*uc
	newline character	terminator	1	uc
	<b>TOTAL</b>		<b>1247</b>	

**Table 2.3.1-1 Product MPH Description**

## 2.3.2 Specific Product Header (SPH)

The Specific Product Header is an ASCII header common to all Level 2 products.

Field #	Description	Units	Bytes	Data Type
<i>Product description and identification</i>				
<b>#1</b>	<b>SPH_DESCRIPTOR=</b>	keyword	15	15*uc
	quotation mark (")		1	uc
	ASCII string describing the product		28	28*uc Product ID Specific Header See Product ID in table 3-1
	quotation mark (")		1	uc
	newline character	terminator	1	uc
<i>Product Time information</i>				
<b>#2</b>	<b>START_RECORD_TAI_TIME=</b>	keyword	22	22*uc
	quotation mark (")		1	uc
	TAI of the first record in the Main MDS of this product	TAI	27	dd-MMM-yyyy hh:mm:ss.uuuuuu
	quotation mark (")		1	uc
	newline character	terminator	1	uc
<b>#3</b>	<b>STOP_RECORD_TAI_TIME=</b>	keyword	21	21*uc
	quotation mark (")		1	uc
	TAI of the last record in in the Main MDS of this product	TAI	27	dd-MMM-yyyy hh:mm:ss.uuuuuu
	quotation mark (")		1	uc
	newline character	terminator	1	uc
<i>Product Orbit Information</i>				
<b>#4</b>	<b>ABS_ORBIT_START=</b>	Keyword	16	16*uc
	Absolute Orbit Number at Product Start Time		6	%06d
	Newline character	terminator	1	uc



<b>#5</b>	<b>REL_TIME_ASC_NODE_START</b> =	Keyword	24	24*uc
	Relative time since crossing ascending node time relative to start time of data sensing	s	11	%011.6f
	<s>	units	3	3*uc
	Newline character	terminator	1	Uc
<b>#6</b>	<b>ABS_ORBIT_STOP</b> =	Keyword	15	15*uc
	Absolute Orbit Number at Product Stop Time		6	%06d
	Newline character	terminator	1	uc
<b>#7</b>	<b>REL_TIME_ASC_NODE_STOP</b> =	Keyword	23	23*uc
	Relative time since crossing ascending node time relative to stop time of data sensing	s	11	%011.6f
	<s>	units	3	3*uc
	Newline character	terminator	1	uc
<b>#8</b>	<b>EQUATOR_CROSS_TIME_UTC</b> =	Keyword	23	23*uc
	Quotation mark (")		1	uc
	Time of Equator crossing at the ascending node of the sensing start time	UTC	27	dd-MMM-yyyy hh:mm:ss.uuuuuu
	Quotation mark (")		1	uc
	Newline character	terminator	1	uc
<b>#9</b>	<b>EQUATOR_CROSS_LONG</b> =	Keyword	19	19*uc
	Longitude of Equator Crossing at the ascending node of the sensing start time (positive East, 0 = Greenwich) referred to WGS84	s	11	%+011d
	<10-6degE>	units	10	10*uc
	Newline character	terminator	1	uc
<b>#10</b>	<b>ASCENDING_FLAG</b> =	Keyword	15	15*uc
	Orbit Orientation at the sensing start time A= Ascending D= Descending		1	uc
	Newline character	terminator	1	uc
<i>Product Location Information</i>				
<b>#11</b>	<b>START_LAT</b> =	keyword	10	10*uc
	WGS84 latitude of the first record in the Main MDS (positive north)	[10-6 deg]	11	%+011d



	<10-6degN>	units	10	10*uc
	newline character	terminator	1	uc
#12	<b>START_LONG=</b>	keyword	11	11*uc
	WGS84 longitude of the first record in the Main MDS (positive East, 0 = Greenwich)	[10-6 deg]	11	%+011d
	<10-6degE>	units	10	10*uc
	newline character	terminator	1	uc
#13	<b>STOP_LAT=</b>	keyword	9	9*uc
	WGS84 latitude of the last record in the Main MDS (positive north)	[10-6 deg]	11	%+011d
	<10-6degN>	units	10	10*uc
	newline character	terminator	1	uc
#14	<b>STOP_LONG=</b>	keyword	10	10*uc
	WGS84 longitude of the last record in the Main MDS (positive East, 0 = Greenwich)	[10-6 deg]	11	%+011d
	<10-6degE>	units	10	10*uc
	newline character	terminator	1	uc
#15	<b>Spare (blank characters)</b>	ascii	50	50*uc
	newline character	terminator	1	uc
<i>Level 1B Quality information</i>				
#16	<b>L1_PROC_FLAG=</b>	keyword	13	13*uc
	Processing errors significance flag (1 or 0).  1 if the percentage of L1B records free of processing errors is less than the acceptable threshold		1	uc
	newline character	terminator	1	uc
	<b>L1_PROCESSING_QUALITY=</b>	keyword	22	22*uc
#17	Percentage of quality checks successfully passed during the L1B processing (max allowed +10000 )	[10-2 %]	6	%+06d
	<10-2%>	units	7	7*uc
	newline character	terminator	1	uc
#18	<b>L1_PROC_THRESH=</b>	keyword	15	15*uc
	Minimum acceptable percentage of quality threshold that must be passed during L1B processing (max allowed +10000)	[10-2 %]	6	%+06d



#19	<10-2%>	units	7	7*uc
	newline character	terminator	1	uc
	<b>NUM_L1_DSR_PROC=</b>		16	16*uc
	Number of L1B Data Set Records analysed		11	%+011d
#20	newline character	terminator	1	uc
	<b>Spare (blank characters)</b>	ascii	50	50*uc
	newline character	terminator	1	uc
<i>SIRAL Mode Statistics</i>				
#21	<b>LRM_MODE_PERCENT=</b>	keyword	17	17*uc
	Percentage of input L1B records detected in LRM mode	[10-2 %]	6	%+06d
	<10-2%>	units	7	7*uc
	newline character	terminator	1	uc
#22	<b>SAR_MODE_PERCENT=</b>	keyword	17	17*uc
	Percentage of input L1B records detected in SAR mode	[10-2 %]	6	%+06d
	<10-2%>	units	7	7*uc
	newline character	terminator	1	uc
#23	<b>SARIN_MODE_PERCENT=</b>	keyword	19	19*uc
	Percentage of input L1B records detected in SARIN mode	[10-2 %]	6	%+06d
	<10-2%>	units	7	7*uc
	newline character	terminator	1	uc
#24	<b>OTHER_MODES_PERCENT=</b>	keyword	20	20*uc
	Percentage of input L1B records detected in any other mode	[10-2 %]	6	%+06d
	<10-2%>	units	7	7*uc
	newline character	terminator	1	uc
#25	<b>Spare (blank characters)</b>	ascii	50	50*uc
	newline character	terminator	1	uc
<i>Level 2 Processing information</i>				
#26	<b>L2_PROD_STATUS=</b>	keyword	15	15*uc
	Complete/Incomplete Product Completion Flag (0 or 1).  1 if the Product as a duration shorter than the input product.		1	uc
	newline character	terminator	1	uc
	#27	<b>L2_PROC_FLAG=</b>	keyword	13

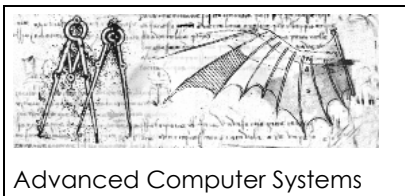

#28	Processing errors significance flag (1 or 0).  1 if the percentage of DSR free of processing errors is less than the acceptable threshold		1	uc
	newline character	terminator	1	uc
	<b>L2_PROCESSING_QUALITY=</b>	keyword	22	22*uc
	Percentage of quality checks successfully passed during Level 1B processing (max allowed +10000)	[10-2 %]	6	%+06d
	<10-2%>	units	7	7*uc
#29	newline character	terminator	1	uc
	<b>L2_PROC_THRESH=</b>	keyword	15	15*uc
	Minimum acceptable percentage of quality threshold that must be passed during Level 1B processing (max allowed +10000)	[10-2 %]	6	%+06d
#30	<10-2%>	units	7	7*uc
	newline character	terminator	1	Uc
	<b>Spare (blank characters)</b>	ascii	50	50*uc
	newline character	terminator	1	Uc
<b>TOTAL</b>			<b>949</b>	

*DSD Section*

**Table 2.3.2-1 Product SPH Description**

Notes:

- Fields 16 – 17 – 18 – 19 are aimed to provide summary quality information of the input L1B that was the source for the higher L2 processing. These fields are derived from the input L1B and transferred in the output L2 SIR\_LRM\_2\_ – SIR\_SAR\_2A – SIR\_SIN\_2\_.

For the Level 2 SIR\_SAR\_2B the fields 16 – 17 – 18 - 19 are copied from the corresponding fields of the SIR\_SAR\_2A.

For the Level 2 GDR (SIR\_GDR\_2A and SIR\_GDR\_2B) field 17 is computed from the corresponding fields of the input products taking in to account the number of the DSR records in the input file which is available in field 19 of the input L2 products and recomputing the percentage as a weighted sum over the input products. Field 18 matches the threshold

specified in the processor configuration file for the L2 GDR processing and field 16 is then computed accordingly from field 17 and 19 using the threshold level in field 18.

- ❑ Fields 21 – 22 – 23 – 24 are mainly aimed for the GDR products (which are merged products) providing statistical information on the amount of data in the product belonging to the LRM – SAR – SARIN or other modes. These fields will be computed from the Mode information that is available in both L1B and L2 records.
  
- ❑ Fields 26 – 27 – 28 – 29 provide summary quality information of the Level 2 product L2 SIR\_LRM\_2\_ – SIR\_SAR\_2A / B – SIR\_SIN\_2\_ - SIR\_GDR\_2A /B. The calculation of the quality parameters is based on the analysis of the MCD field available in the records.

The DSD Section shall actually be divided in two principal sections, Measurement DSD, indicated as DSD (M) and Reference DSD, indicated as DSD (R). The general structure of a DSD is shown in table 2.3.2-2. The size of a DSD is 280 bytes.

#N	<i>DSD</i>			
<b>#N.1</b>	<b>DS_NAME=</b>	keyword	8	8*uc
	quotation mark		1	uc
	Name describing the Data Set		28	28*uc
	quotation mark		1	uc
	newline character	terminator	1	uc
<b>#N.2</b>	<b>DS_TYPE=</b>	keyword	8	8*uc
	Type of Data Set. It can be:		1	uc
	M = Measurement R = Reference			
	newline character	terminator	1	uc
<i>External product reference</i>				
<b>#N.3</b>	<b>FILENAME=</b>	keyword	9	9*uc

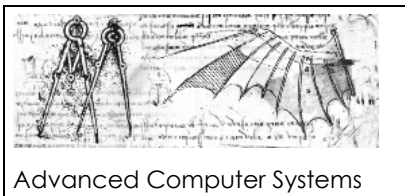

	quotation mark		1	uc
	Name of the Reference File.		62	62*uc
	Used if DS_TYPE is set to R. It is left justified with trailer blanks. The file name includes the extension. If not used it is set to 62 blanks.			
	quotation mark		1	uc
	newline character	terminator	1	uc
<i>Position and size of DS</i>				
<b>#N.4</b>	<b>DS_OFFSET=</b>	keyword	10	10*uc
	Length in bytes of MPH + SPH (including DSDs) + DS size of previous Data Set (if any).	byte	21	%+021d
	<bytes>	units	7	7*uc
	newline character	terminator	1	uc
<b>#N.5</b>	<b>DS_SIZE=</b>	keyword	8	8*uc
	Length in bytes of the attached Data Set Used if DS_TYPE is set to M If not used set to 0	byte	21	%+021d
	<bytes>	units	7	7*uc
	newline character	terminator	1	uc
<i>Number and length of DSRs</i>				
<b>#N.6</b>	<b>NUM_DSR=</b>	keyword	8	8*uc
	Number of Data Set Records		11	%+011d
	newline character	terminator	1	uc
<b>#N.7</b>	<b>DSR_SIZE=</b>	keyword	9	9*uc
	Length in bytes of the Data Set Record If not used set to +0 If variable set to -1	byte	11	%+011d
	<bytes>	units	7	7*uc
	newline character	terminator	1	uc
<b>#N.8</b>	<b>Spare</b>	ascii	32	32*uc
	newline character	terminator	1	uc

**Table 2.3.2-2 Generic DSD Description**

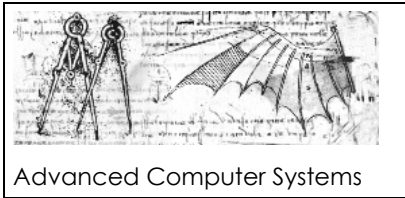

For convenience the Measurement DSD should appear first in the list, followed by all the needed Reference DSDs.

The effective size of the SPH in number of bytes is defined in field #37 SPH\_SIZE of the MPH.

The total number of DSD Descriptors is defined in field #38 of the MPH.

The number of Measurement DSDs is defined in field #40 of the MPH.

For the Measurement Data Sets the DSD (M) may have the following options for the DS\_NAME:

<i>DS_NAME for Measurement DSD</i>
SIR_LRM_L2
SIR_SAR_L2A
SIR_SAR_L2B
SIR_SIN_L2
SIR_GDR_2A
SIR_GDR_2B

**Table 2.3.2-3 DS Names for Measurement Data Sets DSD**

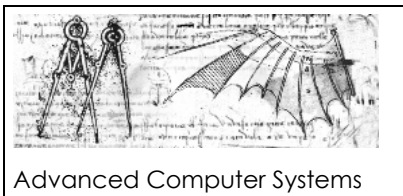

For the Reference DSDs it is proposed to include all the reference DSDs of the source L1B file, in order to provide a Level 2 product which contains all the references to the files that were used along the IPF1 / IPF2 processing chain to generate the product.

In addition some new DSDs have to be introduced and the complete list is supplied here after:

CONSTANTS_FILE	Constants File
PROC_CONFIG_PARAMS_FILE	Processor Configuration Paramaters File
SIRAL_LEVEL_0_FILE	SIRAL LEVEL 0 File from which the L1B product was created
SIRAL_LEVEL_1B_FILE	SIRAL LEVEL 1B File from which the product was created
SIRAL_LEVEL_2_FILE	SIRAL LEVEL 2 File from which the GDR product was created
SCENARIO_FILE	Orbit Scenario File
ORBIT_FILE	Orbit Data File
STAR_TRACKER_LEVEL_0_FILE	Star Tracker Level 0 File
DORIS_USO_DRIFT_FILE	DORIS USO Drift File
FOS_PLATFORM_DATA_FILE	FOS Platform Data File
FOS_HK_TM_FILE	FOS Sorted HouseKeeping Telemetries File
IPF_RA_DATABASE_FILE	Instrument Characterisation Data File
CALIBRATION_TYPE_1_FILE	File Product containing CAL_1 corrections
CALIBRATION_TYPE_2_FILE	File Product containing CAL_2 corrections
CALIBRATION_TYPE_3_FILE	File Product containing the CAL_3 corrections
OCEAN_TIDE_FILE	File for Ocean Tide
TIDAL_LOADING_FILE	File for Tidal Loading
EARTH_TIDE_FILE	CartWright File
POLE_TIDE_FILE	Pole Location Data File
SURFACE_TYPE_FILE	Surface Type Map File
MODIFIED_DIP_MAP_FILE	Modified Dip Map File used for BENT Ionospheric Correction
IONO_COEFFICENTS_FILE	Ionospheric Coefficients file used for BENT Ionospheric Correction
SAI_FILE	Solar Activity Index File used for BENT Ionospheric Correction
DORIS_TEC_FILE	DORIS Total Electron Content File used for Ionosphere Correction
SURFACE_PRESSURE_FILE	Surface Pressure File for Meteo Correction
MEAN_PRESSURE_FILE	Mean Pressure File for Meteo Correction
WET_TROPOSHERE_FILE	Wet Troposphere File for Meteo Correction
DRY_ROPOSPHERE_FILE	Dry Troposphere File for Meteo Correction
U_WIND_FILE	U Wind component File for Meteo Correction
V_WIND_FILE	V Wind component File for Meteo Correction
METEO_GRID_DEF_FILE	Meteo Grid Definition File
DEM_MODEL_FILE	DEM Model File
ARCTIC_SLOPE_FILE	Arctic Slope File
ANTARCTIC_SLOPE_FILE	Antarctic Slope File
MEAN_SEA_SURFACE_FILE	Mean Sea Surface File
SNOW_DEPTH_CLIMATE_FILE	Snow depth Climatology File
SEA_ICE_CONCENTRATION_FILE	Sea Ice Concentration File
GEOID_FILE	Geoid File

**Table 2.3.2-5 DS Names for Reference DSDs**

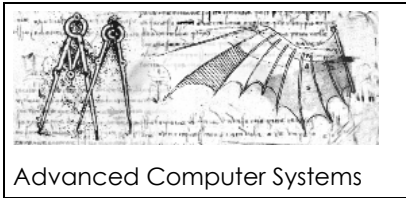

Advanced Computer Systems



*Instrument Processing Facility L1b*

Doc. No.: *CS-RS-ACS-GS-5123*  
Issue: *1.0*  
Date: *31 January 2004*  
Page: *36*

### **2.3.3 Measurement Data Set Record (MDS)**

The L2 Measurement Data Set has a single format which is independent of mode. This is documented in document [L2-IODD].

