



Advanced Computer Systems



*Instrument Processing Facility L1b*

Doc. No.: *CS-RS-ACS-GS-5106*  
Issue: *4.6*  
Date: *15/09/2009*  
Page: *1*

---

## **CRYOSAT Ground Segment**

### **Instrument Processing Facility L1b**

## **Products Specification Format**

**[PROD-FMT]**

---

**CS-RS-ACS-GS-5106**

**Issue: 4.6**

**Date: 15/09/2009**



Advanced Computer Systems



Instrument Processing Facility L1b

Doc. No.: CS-RS-ACS-GS-5106  
Issue: 4.6  
Date: 15/09/2009  
Page: 2

## Document Signature Table

APPROVAL TABLE		
Date		
Name	Function	Signature
P.L. MANTOVANI	Project Manager	
N. MIRANDA	ESA Technical Officer	
P. GILLES	Cryosat PDGS Manager	

CONTRACTOR TABLE				
	Name	Function	Signature	Date
<b>Author</b>	ACS team			
<b>Verification</b>	M.Epifani	System Engineer		
<b>Quality Assurance</b>	A. Giustiniani	Quality Manager		
<b>Approval</b>	P.L. Mantovani	IPF Project Manager		

## Distribution List

Internal Distribution	
Name	No. Copies
P. Mantovani	1
V.Spaventa	1
M. Epifani	1
C. Zelli	1

External Distribution		
Company	Name	No. Copies
ESA-ESRIN	N. Miranda - IPF1 Engineer	1

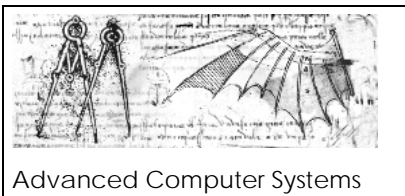

*Instrument Processing Facility L1b*

Doc. No.: *CS-RS-ACS-GS-5106*  
Issue: *4.6*  
Date: *15/09/2009*  
Page: *3*

ESA-ESRIN	P. Femenias – IPF2 Engineer	1
ESA-ESRIN	P. Gilles - Cryosat 2 Mission Manager	1
ARESIS	D. Daria - System Engineer	1

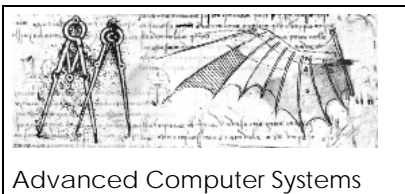

## Document Change Record

Issue/Rev.	Class (R=Review /A=Approval)	Date	Reason for Change	Changed Pages/Paragraphs
<b>Cryosat 1</b>				
1	R	10/04/2002	Initial Issue for SRR	all
1.8	R	17/05/2002	Update for Co-location Meeting	See side bars
1.9	R	12/07/2002	Comments following Co-Location Meeting Delivery for ADR	See side bars
2.0	R	20/12/2002	Outcomes of Actions issued in the ADR Meeting.	See side bars
2.1	R	25/02/2003	<p>Alignment of document for Va 2.0 SW re-delivery. The following items are covered in this update:</p> <p>SPR93</p> <p>Definition of Start and Stop Time in product filenames and product MPH as for CS-MN-ACS-GS-5217</p> <p>Correction of Percentage fields from 10-3 to 10-2 in Product Headers</p> <p>NOTE THAT THIS IS AN INTERIM VERSION OF THE PROD_FMT: FURTHER CHANGES ALREADY DISCUSSED DURING FAT-VA WILL BE INCLUDED AFTER VA 2.0 REDELIVERY TO ALLOW CORRECT DEVELOPMENT OF VB SW PROCESSORS.</p>	See side bars

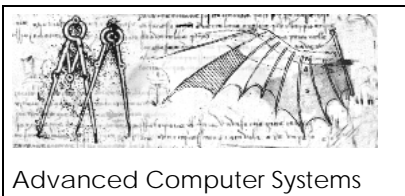

Issue /Rev.	Class (R=Review /A=Approval)	Date	Reason for Change	Changed Pages/Paragraphs
2.2	A	25/04/2003	Global Revision of Product Headers and Update of Records Structure	
2.3	A	13/06/2003	Includes updates of MCD fields and CAL1 / CAL2 product layouts as per agreements in MoM CS-MS-ACS-GS-5219	
2.4	A	20/10/2003	Update of CAL3 L1B and SARIN L1B Product Layouts as for agreements with MSSL  Inclusion of NPM quality flag in FBR and L1B MCD  Modification of CAL1-SARIN MCD definition to separate quality information of Rx1 and Rx2 channels.  Inclusion of Platform Attitude Control flag in MODE_ID field  Inclusion of SAR/SARIN processing specific flags in MCD for L1B product  Revision of Product Header.	
2.5	A	30/11/2003	Inclusion of statement about the exotic units in products  Inclusion of scaling factors in Monitoring Products	
2.6	A	31/01/2004	Inclusion of scaling factors in CAL1 Products + XML DSD definition + typographical	
2.7	A	26/11/2004	Inclusion of Exotic CAL1 Product + corrections	
2.8	A	16/05/2005	XML and ASCII SPH modified to introduce Surface Id Statistics fields (Task#6 IPF1-CCN6)  List of DS_NAME for Measurement DSD updated to account for Fast Delivery Ocean Processing Chain.  FBR and L1B MCD updated: obsolete External COM Correction bit field removed; flags to trace exotic CAL1 file have been introduced  IPF1 Products List updated with FDM products	
2.9	A	02/08/2005	Inclusion of fields descriptions	

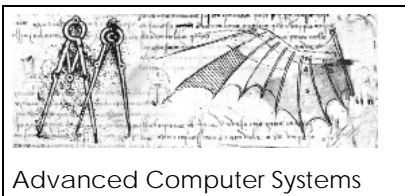

Advanced Computer Systems



Instrument Processing Facility L1b

Doc. No.: CS-RS-ACS-GS-5106  
 Issue: 4.6  
 Date: 15/09/2009  
 Page: 6

3.0	A	09/09/2005	Typo errors corrections	See Sidebars
3.1	A	24/06/2006	Inclusion of new DS Name for new geocorrections files	See Sidebars
3.2	A	10/07/2007	Definition of 'Flags' field in SAR Average Waveform Group added	See Sidebars
<b>Cryosat 2</b>				
4.0	R	12/12/2007	Vh 1.0 delivery (SIRAL redundancy)	See Sidebars
4.1	R	16/06/2008	Two Beam Behaviour parameters added	See sidebars
4.2	R	15/11/2008	Added new applicables to trace the CCN#1 requirements	Sec. 1.3.1
4.3	R	27/02/2009	Updated note on phase slope (field 33)	Table 2.3.4-1: phase slope correction in L1B MDS record
			Updated note on internal phase correction (field 30)	Table 2.3.4-1: internal phase correction in L1B MDS record
			Updated note on external phase correction (field 31)	Table 2.3.4-1: external phase correction in L1B MDS record
			Updated note on internal phase correction (field 30)	Table 2.3.3-1: internal phase correction in FBR MDS record
			Updated note on external phase correction (field 31)	Table 2.3.3-1: external phase correction in FBR MDS record
			Added Correction Error Flag for new DAC geocorrection, as for CCN#2	Sec. 2.3.3, table 2.3.3-6
			Added Correction Status Flag for new DAC geocorrection, as for CCN#2	Sec. 2.3.3, table 2.3.3-5
			Added new DAC geocorrection and a spare byte in the Correction Group of MDS record, as for CCN#2	Sec. 2.3.3, table 2.3.3-1: FBR MDS Records Sec. 2.3.4-1, table 2.3.3-5: L1B MDS records
			Reference to DORIS ionospheric correction has been replaced with GIM, because DORIS ionospheric correction data have been removed by PDGS.	Sec. 2.3.3, table 2.3.3-1: FBR MDS Records Sec. 2.3.4-1, table 2.3.3-5: L1B MDS records
Removed reference to DRYTRP file Added reference to MOG_2D file	Table 2.3.2-5 DS Names for Reference DSDs			
4.4	R	07/04/2009	Modifications agreed at VH1.2 QR	Sec.2.3.4: MCD field "Phase Perturbation Correction Mode" moved to last bit (#0) in table 2.3.4-2
				Sec.2.3.6.3: Added note to clarify storing of PTRs to fields #12 and #23 of the CAL1SARin type1 MDS in table 2.3.6.3-1
				Sec.2.3.6.4: updated description of fields #21, #24, #25, #26 and #27 in table 2.3.6.4-1

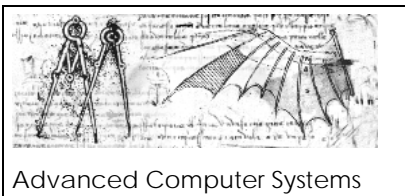

				Sec. 2.3.6.4: updated description of MCD fields #7, #8 and #9 in table 2.3.6.3-2
4.5	R	20/04/2009	New issue after RIDs	<p>Section 1.3: list of reference updated</p> <p>Section 2: page 14: reference to Cal3 removed, added bullet for CAL products and L1b product tree</p> <p>Section 2.3: references to CAL3 removed from SPH</p> <p>Section 2.3, Table 2.3.4-2: bitfield Orbit Propagation Error is changed to bold type face because is used to set the BlockDegraded bitfield.</p> <p>Section 2.2.2.1: REF DOC example updated</p> <p>Section 3.1: setting of Valididty start and stop time updated as for relevant CR</p>
4.6	R	15/09/2009	MCD field table for FBR product changed	Table 2.3.4-2: removed unused fields.

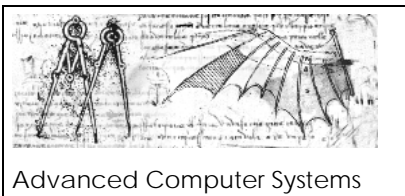

## TABLE OF CONTENTS

<b>1</b>	<b>INTRODUCTION .....</b>	<b>10</b>
1.1	PURPOSE AND SCOPE .....	10
1.2	DOCUMENT STRUCTURE.....	10
1.3	APPLICABLE & REFERENCE DOCUMENTS .....	11
1.3.1	<i>Applicable Documents.....</i>	<i>11</i>
1.3.2	<i>Reference Documents.....</i>	<i>11</i>
1.4	ACRONYMS AND ABBREVIATIONS .....	13
<b>2</b>	<b>LEVEL-1 GENERAL FORMAT DESCRIPTION .....</b>	<b>14</b>
2.1	FILE STRUCTURE .....	16
2.2	XML HEADER FILE .....	17
2.2.1	<i>Fixed Header (Cryosat Header).....</i>	<i>17</i>
2.2.2	<i>Variable Header (Product Header).....</i>	<i>18</i>
2.2.2.1	XML Main Product Header (XML MPH).....	18
2.2.2.2	XML Specific Product Header (XML SPH) .....	21
2.3	PRODUCT FILES.....	27
2.3.1	<i>Main Product Header (MPH) .....</i>	<i>28</i>
2.3.2	<i>Specific Product Header (SPH).....</i>	<i>35</i>
2.3.3	<i>FBR SAR/SARin MDS Record Structure.....</i>	<i>46</i>
2.3.4	<i>L1b LRM(FDM)/SAR/SARin Data Products MDS Record Structure .....</i>	<i>60</i>
2.3.5	<i>Monitoring MDS Record Structure .....</i>	<i>76</i>
2.3.5.1	LRM/TRK Monitoring MDS Record Structure.....	76
2.3.5.2	SAR Monitoring MDS Record Structure .....	80
2.3.5.3	SARIN Monitoring MDS Record Structure.....	82
2.3.5.4	CAL4 Monitoring MDS Record Structure.....	84
2.3.6	<i>Cal1 MDS Record Structures .....</i>	<i>86</i>
2.3.6.1	Cal1 LRM MDS Record Structures.....	86
2.3.6.2	Cal1 SAR MDS Record Structures.....	90
2.3.6.3	Cal1 SARIn MDS Record Structures.....	94
2.3.6.4	AUTO CAL1-SARIN MDS Record.....	100
2.3.7	<i>Cal2 MDS Record Structure.....</i>	<i>102</i>
2.3.7.1	Cal2 SAR MDS Record Structure .....	102
2.3.7.2	Cal 2 SARIn MDS Record Structure .....	104
<b>3</b>	<b>CRYOSAT LEVEL-1 PRODUCTS .....</b>	<b>105</b>
3.1	FILE NAMES.....	106



Advanced Computer Systems



*Instrument Processing Facility L1b*

Doc. No.: *CS-RS-ACS-GS-5106*  
Issue: *4.6*  
Date: *15/09/2009*  
Page: *9*

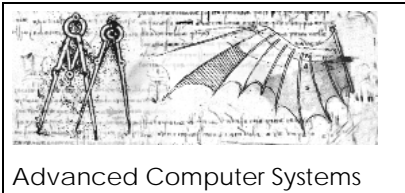

# 1 INTRODUCTION

This document contains the description of the format of all the Level-1 products generated inside the PDS for the Cryosat mission.

## 1.1 PURPOSE AND SCOPE

The purpose of the document is to define the product structure and the content of each Level-1 file generated in the PDS identifying for each data section and field the meaning and the format to be used for its representation.

## 1.2 DOCUMENT STRUCTURE

The document includes the following sections:

Section 1 - Introduction

The present section.

Section 2 - Level-1 General Format Description

This section gives the general description of the Level-1 products in terms of common organisation and format and the detailed description of the format for each file type.

Section 3 - Cryosat Level-1 Products

This section contains the product file name and the composition rules of the file name.

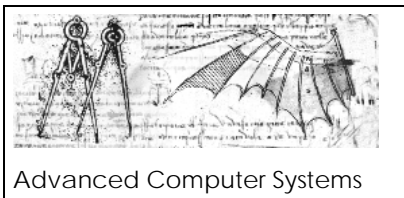

## 1.3 APPLICABLE & REFERENCE DOCUMENTS

### 1.3.1 Applicable Documents

Document Title	Identifier	Reference
Earth Explorer Ground Segment File Format Standard Issue 1.4 , 13 June 2003	CS-TN-ESA-GS-0154	[FMT-GUIDE]
Cryosat Ground Segment Master ICD Issue 4.0, April 2007	CS-ID-ESA-GS-0147	[MASTER-ICD]
CCN #1: Upgrades of IPF1 [IPF1-CCN1] Issue 1.0	C2-CN-ACS-GS-5224	[CCN1-TN]
Minute of CCN#1 negotiation meeting	C2-MN-ACS-GS-5225	[CCN1-NM]
CCN #2: Upgrades of IPF1 [IPF1-CCN2] Issue 1.0	C2-CN-ACS-GS-5229	[CCN2-TN]
Minute of CCN#2 negotiation meeting	C2-MN-ACS-GS-5231	[CCN2-NM]
Minute of ipf1 Vh1.2 QR meeting	C2-MN-ACS_GS-5236	[MOM-QR]

### 1.3.2 Reference Documents

Document Title	Identifier	Reference
IPF1 Detailed Processing Model Issue 2.1, April 2009	CS-TN-ACS-GS-5105	[IPF1-DPM]
Level 0 Products Specification Format Issue 3.1, November 2007	CS-ID-ACS-GS-0119	[L0-FMT]
IEEE Standard for Binary Floating-Point Arithmetic. ANSI/IEEE Std 754-1985 Institute of Electrical and Electronics Engineers Issued 1985	IEEE-754	[IEEE]
Extensible Markup Language (XML) 1.0 (Second Edition) W3C Recommendation 6 October 2000	<a href="http://www.w3.org/TR/2000/REC-xml-20001006">http://www.w3.org/TR/2000/REC-xml-20001006</a>	[XML-GUIDE]
XML Schema Definition Language: W3C XML Schema Working Group and Schema Specifications	<a href="http://www.oasis-open.org/cover/schemas.html#W3CWorkingGroup">http://www.oasis-open.org/cover/schemas.html#W3CWorkingGroup</a>	[XML-SCHEMA]
CCSDS Recommendation Time Code Formats Blue Book Issue 2.0, April 1990	CCSDS 301.0-B-2	[CCSDS-TIMEGUIDE]

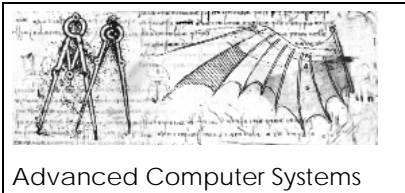

*Instrument Processing Facility L1b*

Doc. No.: *CS-RS-ACS-GS-5106*  
 Issue: *4.6*  
 Date: *15/09/2009*  
 Page: *12*

CCSDS Recommendation Advanced Orbiting System, Networks and Data Links Architectural Specification Blue Book Issue 3.0, June 2001	CCSDS 701.0-B-3	[CCSDS-AOS]
Cryosat Master Interface Control Document Issue 4.6, July 2008	CS-ID-ESA-GS-0147	[CS-ICD]
SIRAL User Manual Issue 10.0	SIRA-ASPI-MA-0228	[SIR-US]

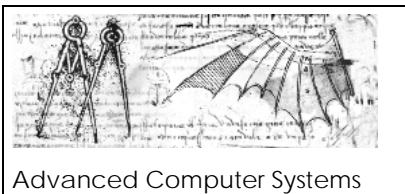

Advanced Computer Systems



*Instrument Processing Facility L1b*

Doc. No.: *CS-RS-ACS-GS-5106*  
Issue: *4.6*  
Date: *15/09/2009*  
Page: *13*

## 1.4 ACRONYMS AND ABBREVIATIONS

<b>ACS</b>	Advanced Computer Systems S.p.A.
<b>AGC</b>	Automatic Gain Control
<b>AIR</b>	Azimuth Impulse Response
<b>AISP</b>	Annotated Instrument Source Packet
<b>APID</b>	Application Process IDentifier
<b>BER</b>	Bit Error Rate
<b>BLOB</b>	Binary Large OBject
<b>CADU</b>	Channel Access Data Unit
<b>CAL</b>	Calibration
<b>CCSDS</b>	Consultative Committee for Space Data Systems
<b>CVCDU</b>	Coded Virtual Channel Data Unit
<b>DSR</b>	Data Set Record
<b>EO</b>	Earth Observation
<b>ESA</b>	European Space Agency
<b>FOS</b>	Flight Operations Segment
<b>FBR</b>	Full Bit Rate
<b>G/S</b>	Ground Segment
<b>HK/TM</b>	Housekeeping/Telemetry data
<b>ID</b>	IDentifier
<b>I/O</b>	Input/Output
<b>ISP</b>	Instrument Source Packet
<b>L1B</b>	Level 1B
<b>LRM</b>	Low Rate Mode
<b>MDS</b>	Measurement Data Set
<b>MJD</b>	Modified Julian Day
<b>MON</b>	Monitoring
<b>MPH</b>	Main Product Header
<b>PDS</b>	Payload Data Segment
<b>PSLR</b>	Peak to Side Lobe Ratio
<b>PSS-05</b>	ESA Software Engineering Standard
<b>rc</b>	Radar Cycle
<b>RIR</b>	Range Impulse Response
<b>SIRAL</b>	Synthetic Interferometric Radar ALtimeter
<b>SOW</b>	Statement Of Work
<b>SPH</b>	Specific Product Header
<b>TAI</b>	International Atomic Time Reference
<b>TBC</b>	To Be Clarified
<b>TBD</b>	To Be Defined
<b>TT&amp;C</b>	Tracking, Telemetry and Command
<b>UTC</b>	Universal Time Co-ordinates
<b>VCID</b>	Virtual Channel IDentifier
<b>VCDU</b>	Virtual Channel Data Unit
<b>WGS84</b>	World Geodetic System 1984
<b>XML</b>	eXtensible Markup Language



## 2 LEVEL-1 GENERAL FORMAT DESCRIPTION

The Level-1 products are derived from the SIRAL Instrument Level 0 data, applying the IPF1 processing algorithms defined in the IPF1 system of PDS.

IPF1 processing chains provide three types of Level1 products:

### □ Level 1B

The L1B data is the main product output from the IPF1. In the case of SAR and SARIN modes of SIRAL, the L1B data are strongly compressed in size following the application of SAR/SARIN algorithms and multilooking for speckle reduction..

### □ Level 1B CAL products

Cal1 and Cal2 products also belong to the L1b class. Cal1 data are available for LRM/SAR/SARIN modes, while CAL2 data are available for SAR/SARIN modes.

### □ FBR

The Full Bit Rate (FBR) product is output at an intermediate stage before the L1B Processing is complete. This is the highest processing stage reached before information compression occurs. In particular the FBR data for SAR and SARIn modes still contain the echo data as complex numbers.

### □ Monitoring

Monitoring data is a systematic product aimed to provide timely information on the health of the instrument. It consists of a set of instrument parameters which may be produced rapidly and routinely starting from LRM/TRK SIRAL data, SAR or SARIN data.

The IPF1 has as output the following L1b products :

- **Level 1B Science Data**
  - LRM Level 1B
  - SAR Level 1B
  - SARIn Level 1B
- **FBR Science Data**
  - SAR FBR
  - SARIn FBR
  - LRM FBR
- **Auxiliary Calibration Data**
  - CAL1 LRM
  - CAL1 SAR



Advanced Computer Systems



*Instrument Processing Facility L1b*

Doc. No.: *CS-RS-ACS-GS-5106*  
Issue: *4.6*  
Date: *15/09/2009*  
Page: *15*

- CAL1 SARIn
- CAL2 SAR
- CAL2 SARIn
- CCAL1 SARIn (Autocal Complex CAL1 data)
- **Monitoring Products**
  - MON LRM/TRK
  - MON SAR
  - MON SARIn

## 2.1 FILE STRUCTURE

The file structure of any file produced by the IPF1 system must follow the requirements of the [FMT-GUIDE] .

Each level-1 product is composed by two files:

- XML Header File
- Product File

The XML Header file is an auxiliary ASCII file that users can easily access for identifying the product without needs to look inside the Product File.

The Product File is the real product containing meaningful instrument's data and ASCII header used by ad hoc developed standard tools for inspecting the product's content. In order to use tools already developed for the ENVISAT mission, the product structure for Cryosat will follow the correspondent one of the ENVISAT products as far as possible.

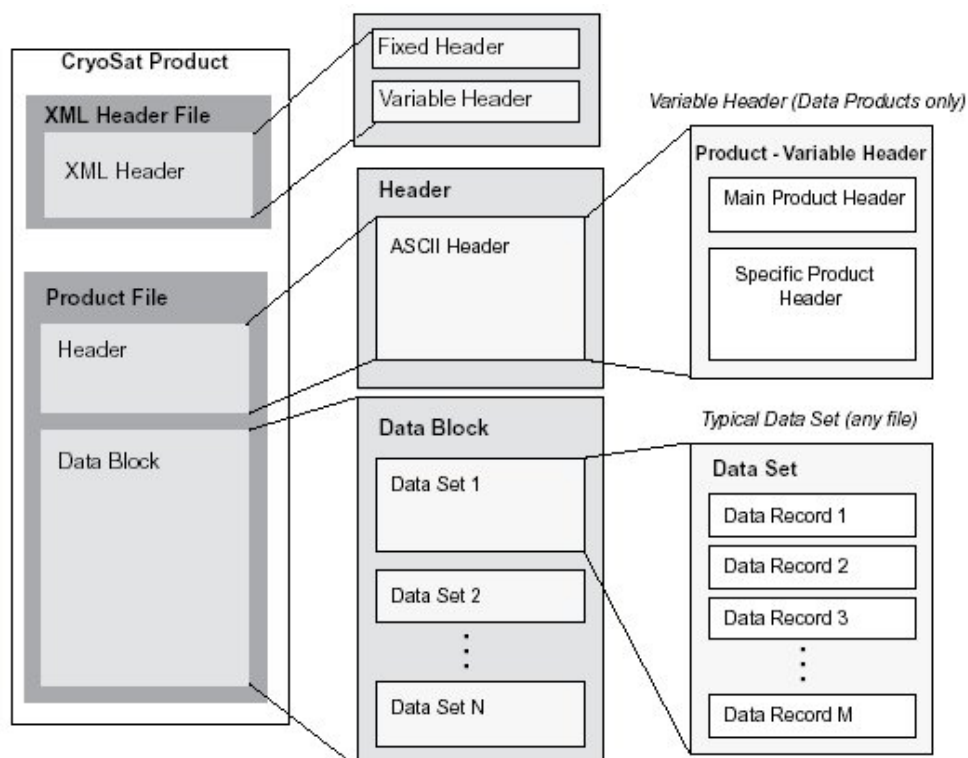



Advanced Computer Systems



*Instrument Processing Facility L1b*

Doc. No.: *CS-RS-ACS-GS-5106*  
Issue: *4.6*  
Date: *15/09/2009*  
Page: *17*

## 2.2 XML HEADER FILE

The XML Header file contains information identifying the product and easy to read as based on a standard syntax accessed by common tools available for visualising its content. The XML syntax has been chosen for the scope of the PDS.

The XML Header file is composed by:

- a Fixed Header
- a Variable Header

The Fixed Header (hereafter called Standard Cryosat Header) is the common header for all files managed into the PDS. That means it is applied to all files flowing amongst the sub-systems composing the PDS.

The Variable Header (hereafter called Product Header) is the header with format and content depending on the file type and kind of product.

### 2.2.1 Fixed Header (Cryosat Header)

The Standard Cryosat Header is completely ASCII and based on XML syntax and conventions proposed in [FMT-GUIDE].

The format and content of the Standard Cryosat Header is under ESA responsibility and it is specified in [FMT-GUIDE].

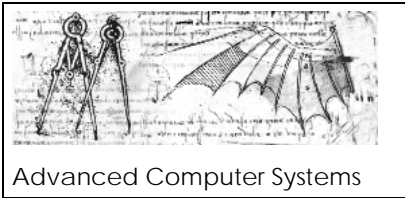

## 2.2.2 Variable Header (Product Header)

The Variable Header (hereafter called Product Header) for the Level 1 product is composed by:

- a XML Main Product Header (XML MPH)
- a XML Specific Product Header (XML SPH) which includes Reference Data Set Descriptors for external input files one or more XML Specific Measurement Data Header (XML MDH) for the Data Sets of the Product

The XML MPH and XML SPH are derived from the correspondent headers (MPH and SPH) of the Product File, removing the unused fields and fields already reported in the Standard Cryosat Header.

Each header is completely ASCII and based on XML syntax and conventions proposed in the [FMT-GUIDE].

The following paragraphs describe the format and content of the XML MPH and XML SPH without overload of the XML format description.

### 2.2.2.1 XML Main Product Header (XML MPH)

Field #	Description	Units	Bytes	Format
	MPH	Tag		
	<i>Product Identification Info</i>			
#01	Product	Tag		
	Product File Name Note: the file name shall be without extension		62	See Section 3
#02	Proc_Stage_Code	Tag		
	Processing stage code identifier: RPR0 = Reprocessing OFFL = Routine Operations NRT_ = Near Real Time TEST = Test LTA_ = Long Term Archive		4	4*uc
#03	Ref_Doc	Tag		
	Reference DFCB Document describing the product		23	CS-RS-ACS-GS-5106 04.00
	<i>Data Processing Information</i>			



#04	Proc_Time	Tag		
	Processing Time (Product Generation Time)		30	UTC=yyyy-mm-ddThh:mm:ss.uuuuuu
#05	Software_Version	Tag		
	Processor Name and software version number.		14	ProcessorName/VV.rr
	<i>Orbit Information</i>			
#06	Phase	Tag		
	Phase Code: If not used set to X		1	uc
#07	Cycle	Tag		
	Cycle number. If not used set to +000		4	%+04d
#08	Rel_Orbit	Tag		
	Relative Orbit Number at sensing start time. If not used set to +00000		6	%+06d
#09	Abs_Orbit	Tag		
	Absolute Orbit Number at sensing start time. If not used set to +00000		6	%+06d
#10	State_Vector_Time	Tag		
	UTC state vector time		30	UTC=yyyy-mm-ddThh:mm:ss.uuuuuu
#11	Delta_UT1	Tag		
	Universal Time Correction: DUT1 = UT1 – UTC If not used set to +.000000	s	8	%+08.6f
#12	X_Position	Tag		
	X position in Earth Fixed Reference If not used set to +0000000.000	m	12	%+012.3f
#13	Y_Position	Tag		
	Y position in Earth Fixed Reference If not used set to +0000000.000	m	12	%+012.3f
#14	Z_Position	Tag		
	Z position in Earth Fixed Reference If not used set to +0000000.000	m	12	%+012.3f
#15	X_Velocity	Tag		
	X velocity in Earth Fixed Reference If not used set to +0000.000000	m/s	12	%+012.6f
#16	Y_Velocity	Tag		
	Y velocity in Earth Fixed Reference	m/s	12	%+012.6f

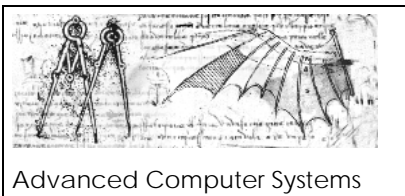

	If not used set to +0000.000000			
<b>#17</b>	Z_Velocity	Tag		
	Z velocity in Earth Fixed Reference If not used set to +0000.000000	m/s	12	%+012.6f
<b>#18</b>	State_Vector_Source	Tag		
	Source of Orbit State Vector Record  FP = FOS predicted DN = DORIS Level 0 navigator DP = DORIS precise orbit FR= FOS Restituted DI = DORIS Preliminary		2	2*uc
<i>Product Confidence Data Information</i>				
<b>#19</b>	Product_Err	Tag		
	Product Error Flag  1 errors have been reported in the Product  0 no errors		1	uc
<i>Product Size Information</i>				
<b>#20</b>	Tot_Size	Tag		
	Total Size of the Data Product	bytes	21	%021d

**Table 2.2.2.1-1: XML Main Product Header Description**

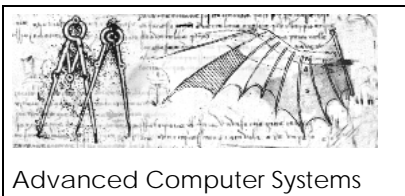

### 2.2.2.2 XML Specific Product Header (XML SPH)

Field #	Description	Units	Bytes	FORMAT
	SPH	tag		
<i>Product description and identification</i>				
#1	SPH_Descriptor	tag		
	Name describing the Specific Product Header		28	<i>ProductID SPECIFIC HEADER See Table 3-1</i>
<i>Product Time information</i>				
	Time_Information	tag		
#2	Start_Record_Time	tag		
	TAI of the first record in the Main MDS of this product		30	TAI=yyyy-mm-ddThh:mm:ss.uuuuuu
#3	Stop_Record_Time	tag		
	TAI of the last record in in the Main MDS of this product		30	TAI=yyyy-mm-ddThh:mm:ss.uuuuuu
<i>Product Orbit information</i>				
	Orbit_Information	Tag		
#4	ABS_Orbit_Start	Tag		
	Absolute Orbit Number at sensing start time.		6	%06d
#5	Rel_Time_ASC_Node_Start	Tag		
	Relative time since crossing ascending node time relative to start time of data sensing.	s	11	%011.6f
#6	ABS_Orbit_Stop	Tag		

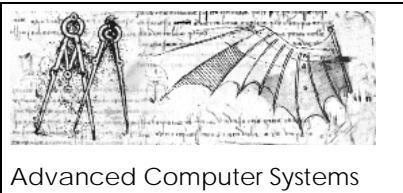

	Absolute Orbit Number at sensing stop time.		6	%06d
#7	Rel_Time_ASC_Node_Stop	Tag		
	Time of the ascending node relative to stop time of data sensing.  Relative time since crossing ascending node time relative to stop time of data sensing.	s	11	%011.6f
#8	Equator_Cross_Time	Tag		
	Time of equator crossing at the ascending node relative to the sensing start time.		30	UTC=yyyy-mm-ddThh:mm:ss.uuuuuu
#9	Equator_Cross_Long	Tag		
	Longitude of equator crossing at the ascending node relative to the sensing start time (positive East, 0 = Greenwich) referred to WGS84.	10-6 deg	11	%+011d
#10	Ascending_Flag	Tag		
	Orbit Orientation at the sensing start time  A=Ascending  D=Descending		1	uc
<i>Product Location Information</i>				
	Product_Location	tag		
#11	Start_Lat	tag		
	WGS84 latitude of the first record in the Main MDS (positive north)	10-6 deg	11	%+011d
#12	Start_Long	tag		
	WGS84 longitude of the first record in the Main MDS (positive East, 0 = Greenwich)	10-6 deg	11	%+011d
#13	Stop_Lat	tag		

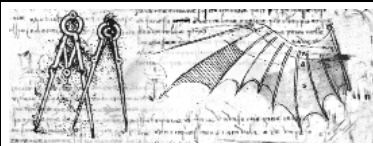

	WGS84 latitude of the last record in the Main MDS (positive north)	10-6 deg	11	%+011d
#14	Stop_Long	tag		
	WGS84 longitude of the last record in the Main MDS (positive East, 0 = Greenwich)	10-6 deg	11	%+011d
<i>SIRAL Level 0 Quality information</i>				
	Level_0_Confidence_Data	tag		
#15	L0_Proc_Flag	tag		
	Processing errors significance flag  1 errors (percentage of errors greater than threshold)  0 no errors		1	uc
#16	L0_Processing_Quality	tag		
	Percentage of quality checks successfully passed during the SP processing (max allowed +10000)	10-2 %	6	%+06d
#17	L0_Proc_Thresh	tag		
	Minimum acceptable percentage of quality threshold that must be passed during SP processing (max allowed +10000)	10-2 %	6	%+06d
#18	L0_Gaps_Flag	tag		
	Flag to indicate gaps in input data  1 gaps  0 no gaps		1	uc
#19	L0_Gaps_Num	tag		
	Number of gaps detected during the SP processing		7	%07d
<i>SIRAL Instrument Configuration</i>				
	SIR_Instrument_Configuration	tag		
#20	Instrument_Identifier	tag	1	1*uc
				A (SIRAL Nominal) B (SIRAL Redundant)



#21	SIR_Op_Mode	tag		
	SIRAL Operative Mode		10	10*uc  LRM_____ SAR_____ SARIN_____ CAL1_LRM_____ CAL1_SAR_____ CAL1_SARIN_____ CAL2_SAR_____ CAL2_SARIN_____ ACQ_____ TRK_SARIN_____ TRK_SAR_____ CAL4_____
#22	SIR_Configuration	tag		
	SIRAL Rx Configuration		7	7*uc  RX_1____ RX_2____ BOTH____ UNKNOWN
<i>Level 1 Surface Statistics</i>				
	Surface_Statistics	tag		
#23	Open_Ocean_Percent	tag		
	Percentage of input L1B records detected on open ocean or semi-enclosed seas	10-2 %	6	%+06d
#24	Close_Sea_Percent	tag		
	Percentage of input L1B records detected on close seas or lakes	10-2 %	6	%+06d
#25	Continent_Ice_Percent	tag		
	Percentage of input L1B records detected on continental ice	10-2 %	6	%+06d
#26	Land_Percent	tag		
	Percentage of input L1B records detected on land	10-2 %	6	%+06d
<i>SIRAL Level 1 Processing information</i>				
	Level_1_Confidence_Data	tag		
#27	L1B_Prod_Status	tag		



	Complete/Incomplete Product Completion Flag (0 or 1).  1 if the Product as a duration shorter than the input Level 0		1	uc
#28	L1B_Proc_Flag	tag		
	Processing errors significance flag 1 errors (percentage of errors greater than threshold) 0 no errors		1	uc
#29	L1B_Processing_Quality	tag		
	Percentage of quality checks successfully passed during Level 1B processing (max allowed +10000)	10-2 %	6	%+06d
#30	L1B_Proc_Thresh	tag		
	Minimum acceptable percentage of quality threshold that must be passed during Level 1B processing (max allowed +10000)	10-2 %	6	%+06d
<i>Data Set Descriptors</i>				
	DSDs	tag		
	List_of_DSDs	tag		
	Data_Set_Descriptor	tag		
#31	Data_Set_Name	tag		
	Name of the Data Set		28	uc
#32	Data_Set_Type	tag		
	M for Measurement – R for Reference		1	uc
#33	File_Name	tag		
	Name of the reference file. Field is left empty for Measurement DSD		62	uc
#34	Data_Set_Offset	tag		
	Offset in bytes from the beginning of the DBL file. For reference DSDs the field is set to 0.	bytes	21	%+021d
#35	Data_Set_Size	tag		
	Size in bytes of the Measurement Data Set Record. For reference DSDs the field is set to 0.	bytes	21	%+021d
#36	Num_of_Records	tag		
	Number of Data Set Records. For reference DSDs the field is set to 0.		11	%+011d

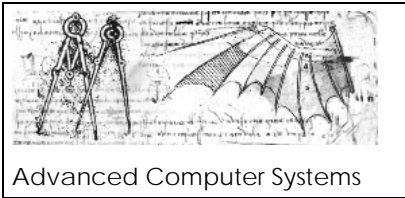

<b>#37</b>	Record_Size	tag		
	Record size in bytes. For reference DSDs the field is set to 0.	bytes	11	%+011d
<b>#38</b>	Byte_Order	tag		
	It describes the endianness of the data set 3210 → Big-endian 0123 → Little-endian For Reference DSDs the field is left empty		4	%4c  3210 for Cryosat

**Table 2.2.2.2-1: XML Specific Product Header description**

### 2.3 PRODUCT FILES

The Product File structure will follow the one defined for the ENVISAT level-0 products as much as possible.

As shown in figure 2.3-1, each product file is composed by:

- Main Product Header (MPH)
- Specific Product Header (SPH)
- Data Sets

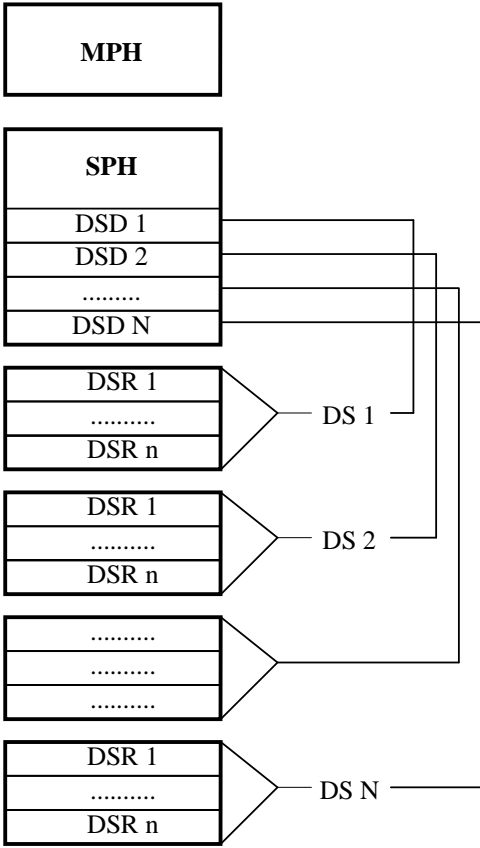

**Figure 2.3-1: Generalised Product Structure**

The MPH and SPH blocks are ASCII and following the current syntax for any composing field:

**FieldName= value<units>**

The Data Sets are completely binary and contains one or more Data Set Records each. According to the following Products definitions the maximum number of DS in a product is two.



### 2.3.1 Main Product Header (MPH)

Field #	Description	Units	Bytes	Format
<i>Product Identification Info</i>				
#01	<b>PRODUCT=</b>	keyword	8	
	quotation mark (")		1	uc
	Product File Name It is left justified with trailer blanks		62	See 3.1
	quotation mark (")		1	uc
	newline character	terminator	1	
#02	<b>PROC_STAGE=</b>	keyword	11	11*uc
	Processing stage code: N = Near-Real Time T = Test O = OFF Line (Systematic) R = Reprocessing L = Long Term Archive		1	
	newline character	terminator	1	
#03	<b>REF_DOC=</b>	keyword	8	8*uc
	quotation mark (")		1	uc
	Reference DFCB Document describing the product		23	23*uc
	quotation mark (")		1	uc
	newline character	terminator	1	
#04	<b>Spare</b> (blank characters)		40	40*uc
	newline character	terminator	1	uc
<i>Data Processing Information</i>				
#05	<b>ACQUISITION_STATION=</b>	keyword	20	20*uc
	quotation mark (")		1	uc
	Acquisition Station ID Filled by blanks		20	Kiruna
	quotation mark (")		1	uc
	newline character	terminator	1	
#06	<b>PROC_CENTER=</b>	keyword	12	12*uc
	quotation mark (")		1	uc
	Processing Center ID code		6	PDS
	quotation mark (")		1	uc



	newline character	terminator	1	
#07	<b>PROC_TIME=</b>	keyword	10	10*uc
	quotation mark (")		1	uc
	Processing Time (Product Generation Time)	UTC	27	dd-MMM-yyyy hh:mm:ss.uuuuuu
	quotation mark (")		1	uc
	newline character	terminator	1	
#08	<b>SOFTWARE_VER=</b>	keyword	13	13*uc
	quotation mark (")		1	uc
	Processor name, up to 8 characters, and software version number followed by trailer blanks if any. If not used set to blanks		14	14*uc ProcessorName/VV.rr
	quotation mark (")		1	uc
	newline character	terminator	1	
#09	<b>Spare</b> (blank characters)		40	40*uc
	newline character	terminator	1	uc
<i>Information on Time of Data</i>				
#10	<b>SENSING_START=</b>	keyword	14	14*uc
	quotation mark (")		1	uc
	UTC start time of data sensing. This is the UTC start time of the Input Level 0 Product. If not used set to 27 blanks	UTC	27	dd-MMM-yyyy hh:mm:ss.uuuuuu
	quotation mark (")		1	uc
	newline character	terminator	1	
#11	<b>SENSING_STOP=</b>	keyword	13	13*uc
	quotation mark (")		1	uc
	UTC stop time of data sensing. This is the UTC stop time of the Input Level 0 Product. If not used set to 27 blanks	UTC	27	dd-MMM-yyyy hh:mm:ss.uuuuuu
	quotation mark (")		1	uc
	newline character	terminator	1	
#12	<b>Spare</b> (blank characters)		40	40*uc
	newline character	terminator	1	uc
<i>Orbit Information</i>				
#13	<b>PHASE=</b>	keyword	6	6*uc
	Phase Code: phase letter (A, B, ...) If not used set to X		1	



	newline character	terminator	1	uc
#14	<b>CYCLE=</b>	keyword	6	6*uc
	Cycle number. If not used set to +000		4	%+04d
	newline character	terminator	1	uc
#15	<b>REL_ORBIT=</b>	keyword	10	10*uc
	Relative Orbit Number at sensing start time. If not used set to +00000		6	%+06d
	newline character	terminator	1	uc
#16	<b>ABS_ORBIT=</b>	keyword	10	10*uc
	Absolute Orbit Number at sensing start time. If not used set to +00000		6	%+06d
	newline character	terminator	1	uc
#17	<b>STATE_VECTOR_TIME=</b>	keyword	18	18*uc
	quotation mark (")		1	uc
	UTC state vector time It is filled properly in case of usage of FOS Predicted Orbit information otherwise it shall be set to 27 blanks	UTC	27	dd-MMM-yyyy hh:mm:ss.uuuuuu
	quotation mark (")		1	uc
	newline character	terminator	1	
#18	<b>DELTA_UT1=</b>	keyword	10	10*uc
	Universal Time Correction: DUT1 = UT1 – UTC Not used for Cryosat. It shall be set to +.000000	s	8	%+08.6f
	<s>	units	3	3*uc
	newline character	terminator	1	
#19	<b>X_POSITION=</b>	keyword	11	11*uc
	X position in Earth Fixed Reference. If not used set to +0000000.000	m	12	%+012.3f
	<m>	units	3	3*uc
	newline character	terminator	1	
#20	<b>Y_POSITION=</b>	keyword	11	11*uc
	Y position in Earth Fixed Reference. If not used set to +0000000.000	m	12	%+012.3f
	<m>	units	3	3*uc



	newline character	terminator	1	
#21	<b>Z_POSITION=</b>	keyword	11	11*uc
	Z position in Earth Fixed Reference. If not used set to +0000000.000	m	12	%+012.3f
	<m>	units	3	3*uc
	newline character	terminator	1	
#22	<b>X_VELOCITY=</b>	keyword	11	11*uc
	X velocity in Earth Fixed Reference. If not used set to +0000.000000	m/s	12	%+012.6f
	<m/s>	units	5	5*uc
	newline character	terminator	1	
#23	<b>Y_VELOCITY=</b>	keyword	11	11*uc
	Y velocity in Earth Fixed Reference. If not used set to +0000.000000	m/s	12	%+012.6f
	<m/s>	units	5	5*uc
	newline character	terminator	1	
#24	<b>Z_VELOCITY=</b>	keyword	11	11*uc
	Z velocity in Earth Fixed Reference. If not used set to +0000.000000	m/s	12	%+012.6f
	<m/s>	units	5	5*uc
	newline character	terminator	1	
#25	<b>VECTOR_SOURCE=</b>	keyword	14	14*uc
	quotation mark (")		1	uc
	Source of Orbit State Vector Record FP = FOS predicted DN = DORIS Level 0 navigator DP = DORIS precise orbit FR = FOS Restituted DI = DORIS Preliminary		2	2*uc
	quotation mark (")		1	uc
	newline character	terminator	1	
	<b>Spare (blank characters)</b>		40	40*uc
	newline character	terminator	1	uc
<i>SBT to UTC conversion Information</i>				
#27	<b>UTC_SBT_TIME=</b>	keyword	13	13*uc



	quotation mark (")		1	uc
	Not used and set to 27 blanks		27	\$
	quotation mark (")		1	uc
	newline character	terminator	1	uc
#28	<b>SAT_BINARY_TIME=</b>	keyword	16	16*uc
	Satellite Binary Time Not used for Cryosat and it shall be set to zeros		11	+0000000000
	newline character	terminator	1	uc
#29	<b>CLOCK_STEP =</b>	keyword	11	11*uc
	Clock Step Not used for Cryosat and it shall be set to zeros		11	+0000000000
	<ps>	units	4	4*uc
	newline character	terminator	1	uc
#30	<b>Spare</b> (blank characters)		32	32*uc
	newline character	terminator	1	uc
<i>Leap Second Information</i>				
#31	<b>LEAP.UTC=</b>	keyword	9	9*uc
	quotation mark (")		1	uc
	UTC Time of the occurrence of the leap second. If a leap second occurred in the product window the field is set by a devoted function in the CFI EXPLORER_ORBIT library (see [EXPL_ORB-SUM] for details), otherwise it is set to 27 blanks. It corresponds to the time after the Leap Second occurrence (i.e. midnight of the day after the leap second)		27	dd-MMM-yyyy hh:mm:ss.uuuuuu
	quotation mark (")		1	uc
	newline character	terminator	1	uc
#32	<b>LEAP_SIGN=</b>	keyword	10	10*uc
	Leap second sign If a leap second occurred in the product window the field is set to the expected value by a devoted function in the CFI EXPLORER_ORBIT library (see [EXPL_ORB-SUM] for details), otherwise it is set to +000.	s	4	%+04d
	newline character	terminator	1	uc



#33	<b>LEAP_ERR=</b>	keyword	9	9*uc
	Leap second error flag.		1	uc
	This field is always set to 0 considering that CRYOSAT products have true UTC times			
	newline character	terminator	1	uc
#34	<b>Spare</b> (blank characters)		40	40*uc
	newline character	terminator	1	uc
<i>Product Confidence Data Information</i>				
#35	<b>PRODUCT_ERR=</b>	keyword	12	12*uc
	Product Error Flag set to 1 if errors have been reported in the product		1	uc
	newline character	terminator	1	uc
<i>Product Size Information</i>				
#36	<b>TOT_SIZE=</b>	keyword	9	9*uc
	Total size of the product	bytes	21	%+021d
	<bytes>	units	7	7*uc
	newline character	terminator	1	Uc
#37	<b>SPH_SIZE=</b>	keyword	9	9*uc
	Length of the SPH	bytes	11	%+011d
	<bytes>	units	7	7*uc
	newline character	terminator	1	Uc
#38	<b>NUM_DSD=</b>	keyword	8	8*uc
	Number of Data Set Descriptors, including spares and all other types of DSDs		11	%+011d
	newline character	terminator	1	Uc
#39	<b>DSD_SIZE=</b>	keyword	9	9*uc
	Length of each DSD	bytes	11	%+011d
	<bytes>	units	7	7*uc
	newline character	terminator	1	Uc
#40	<b>NUM_DATA_SETS=</b>	keyword	14	14*uc
	Number of attached Data Sets (note that not all the DSDs have a DS attached)		11	%+011d
	newline character	terminator	1	Uc
#41	<b>CRC=</b>	keyword	4	4*uc
	Cyclic Redundancy Code computed as overall value of all records of the Measurement Data Set. If not computed it shall be set to -00001		6	%+06d

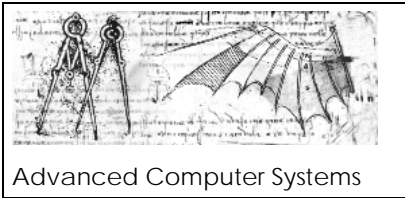

Advanced Computer Systems



*Instrument Processing Facility L1b*

Doc. No.: *CS-RS-ACS-GS-5106*  
 Issue: *4.6*  
 Date: *15/09/2009*  
 Page: *34*

	newline character	terminator	1	Uc
<b>#42</b>	<b>Spare</b> (blank characters)		29	29*uc
	newline character	terminator	1	uc
	<b>TOTAL</b>		<b>1247</b>	

**Table 2.3.1-1 Product MPH Description**

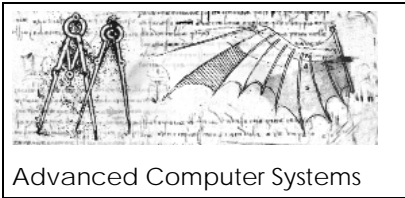

### 2.3.2 Specific Product Header (SPH)

The Specific Product Header is an ASCII header. A general structure valid for all SIRAL IPF1 products is proposed. The proposed SPH structure is as follows.

Field #	Description	Units	Bytes	Data Type
<i>Product description and identification</i>				
#1	<b>SPH_DESCRIPTOR=</b>	keyword	15	15*uc
	quotation mark (")		1	uc
	ASCII string describing the product		28	28*uc Product ID SPECIFIC HEADER See Product ID in table 3-1
	quotation mark (")		1	uc
	newline character	terminator	1	uc
<i>Product Time information</i>				
#2	<b>START_RECORD_TAI_TIME=</b>	keyword	22	22*uc
	quotation mark (")		1	uc
	TAI of the first record in the Main MDS of this product	TAI	27	dd-MMM-yyyy hh:mm:ss.uuuuuu
	quotation mark (")		1	uc
	newline character	terminator	1	uc
#3	<b>STOP_RECORD_TAI_TIME=</b>	keyword	21	21*uc
	quotation mark (")		1	uc
	TAI of the last record in in the Main MDS of this product	TAI	27	dd-MMM-yyyy hh:mm:ss.uuuuuu
	quotation mark (")		1	uc
	newline character	terminator	1	uc
<i>Product Orbit Information</i>				
#4	<b>ABS_ORBIT_START=</b>	Keyword	16	16*uc
	Absolute Orbit Number at Product Start Time		6	%06d



	Newline character	terminator	1	uc
#5	<b>REL_TIME_ASC_NODE_START</b> =	Keyword	24	24*uc
	Relative time since crossing ascending node time relative to start time of data sensing	s	11	%011.6f
	<s>	units	3	3*uc
	Newline character	terminator	1	Uc
#6	<b>ABS_ORBIT_STOP</b> =	Keyword	15	15*uc
	Absolute Orbit Number at Product Stop Time		6	%06d
	Newline character	terminator	1	uc
#7	<b>REL_TIME_ASC_NODE_STOP</b> =	Keyword	23	23*uc
	Relative time since crossing ascending node time relative to stop time of data sensing	s	11	%011.6f
	<s>	units	3	3*uc
	Newline character	terminator	1	uc
#8	<b>EQUATOR_CROSS_TIME_UTC</b> =	Keyword	23	23*uc
	Quotation mark("")		1	uc
	Time of Equator crossing at the ascending node of the sensing start time	UTC	27	dd- <i>MMM</i> -yyyy hh:mm:ss.uuuuuu
	Quotation mark ("")		1	uc
	Newline character	terminator	1	uc
#9	<b>EQUATOR_CROSS_LONG</b> =	Keyword	19	19*uc
	Longitude of Equator Crossing at the ascending node of the sensing start time (positive East, 0 = Greenwich) referred to WGS84	s	11	%+011d
	<10-6degE>	units	10	10*uc
	Newline character	terminator	1	uc
#10	<b>ASCENDING_FLAG</b> =	Keyword	15	15*uc
	Orbit Orientation at the sensing start time A= Ascending D= Descending		1	uc
	Newline character	terminator	1	uc
	<i>Product Location Information</i>			
#11	<b>START_LAT</b> =	keyword	10	10*uc



	WGS84 latitude of the first record in the Main MDS (positive north)	[10-6 deg]	11	%+011d
	<10-6degN>	units	10	10*uc
	newline character	terminator	1	uc
#12	<b>START_LONG=</b>	keyword	11	11*uc
	WGS84 longitude of the first record in the Main MDS (positive East, 0 = Greenwich)	[10-6 deg]	11	%+011d
	<10-6degE>	units	10	10*uc
	newline character	terminator	1	uc
#13	<b>STOP_LAT=</b>	keyword	9	9*uc
	WGS84 latitude of the last record in the Main MDS (positive north)	[10-6 deg]	11	%+011d
	<10-6degN>	units	10	10*uc
	newline character	terminator	1	uc
#14	<b>STOP_LONG=</b>	keyword	10	10*uc
	WGS84 longitude of the last record in the Main MDS (positive East, 0 = Greenwich)	[10-6 deg]	11	%+011d
	<10-6degE>	units	10	10*uc
	newline character	terminator	1	uc
#15	<b>Spare (blank characters)</b>	ascii	50	50*uc
	newline character	terminator	1	uc
<i>Level 0 Quality information</i>				
#16	<b>LO_PROC_FLAG=</b>	keyword	13	13*uc
	Processing errors significance flag (1 or 0).  1 if the percentage of SIRAL packets free of processing errors is less than the acceptable threshold		1	uc
	newline character	terminator	1	uc
	#17	<b>LO_PROCESSING_QUALITY=</b>	keyword	22
Percentage of quality checks successfully passed during the SP processing (max allowed +10000 )		[10-2 %]	6	%+06d
<10-2%>		units	7	7*uc
newline character		terminator	1	uc
#18	<b>LO_PROC_THRESH=</b>	keyword	15	15*uc



#19	Minimum acceptable percentage of quality threshold that must be passed during SP processing (max allowed +10000)	[10-2 %]	6	%+06d
	<10-2%>	units	7	7*uc
	newline character	terminator	1	uc
	<b>LO_GAPS_FLAG=</b>	keyword	13	13*uc
	Gaps significance flag (1 or 0).  1 if gaps (either caused by extraction or alignment failures) were detected during the SP processing		1	uc
#20	newline character	terminator	1	uc
	<b>LO_GAPS_NUM=</b>	keyword	12	12*uc
	Number of gaps detected during the SP processing (no gaps indicated as +0000000)		8	%+08d
#21	newline character	terminator	1	uc
	<b>Spare (blank characters)</b>	ascii	37	37*uc
	newline character	terminator	1	uc



<i>SIRAL Instrument Configuration</i>				
#22	<b>INSTR_ID=</b>	keyword	9	9*uc
	quotation mark (")		1	uc
	Instrument identifier		1	1*uc A = SIRAL Nominal B = SIRAL Redundant
	quotation mark (")		1	uc
	newline character	terminator	1	uc
	#23	<b>SIR_OP_MODE=</b>	keyword	12
quotation mark (")			1	uc
SIRAL Operative Mode:			10	10*uc
LRM\$\$\$\$\$				
SAR\$\$\$\$\$				
SARIN\$\$\$\$\$				
CAL1_LRM\$\$				
CAL1_SAR\$\$				
CAL1_SARIN				
CAL2_SAR\$\$				
CAL2_SARIN				
ACQ\$\$\$\$\$\$				
TRK_SAR\$\$\$				
TRK_SARIN\$				
CAL4\$\$\$\$\$				
(strings shorter than 10 are filled in with blanks \$)				
quotation mark (")		1	uc	
Newline character	terminator	1	uc	
#24	<b>SIR_CONFIGURATION=</b>	keyword	18	17*uc
	quotation mark (")		1	uc



	SIRAL Configuration:		7	7*uc
	RX_1\$\$\$ RX_2\$\$\$ BOTH\$\$\$ UNKNOWN			
	(strings shorter than 7 are filled in with blanks)			
	quotation mark (")		1	uc
	Newline character	terminator	1	uc
<i>Surface ID Statistics</i>				
#25	<b>OPEN_OCEAN_PERCENT=</b>	keyword	19	19*uc
	Percentage of records detected on open ocean or semi-enclosed seas	[10-2 %]	6	%+06d
	<10-2%>	units	7	7*uc
	Newline character	terminator	1	uc
#26	<b>CLOSE_SEA_PERCENT=</b>	keyword	18	18*uc
	Percentage of records detected on close seas or lakes	[10-2 %]	6	%+06d
	<10-2%>	units	7	7*uc
	Newline character	terminator	1	Uc
#27	<b>CONTINENT_ICE_PERCENT=</b>	keyword	22	22*uc
	Percentage of records detected on continental ice	[10-2 %]	6	%+06d
	<10-2%>	units	7	7*uc
	Newline character	terminator	1	Uc
#28	<b>LAND_PERCENT=</b>	keyword	13	13*uc
	Percentage of records detected on land	[10-2 %]	6	%+06d
	<10-2%>	units	7	7*uc
	Newline character	terminator	1	Uc
#29	<b>Spare (blank characters)</b>	ascii	50	50*uc
	newline character	terminator	1	uc
<i>Level 1 Processing information</i>				
#30	<b>L1B_PROD_STATUS=</b>	keyword	16	16*uc

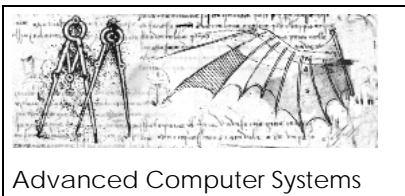

#31	Complete/Incomplete Product Completion Flag (0 or 1).  1 if the Product as a duration shorter than the input Level 0		1	uc
	newline character	terminator	1	uc
	<b>L1B_PROC_FLAG=</b>	keyword	14	14*uc
#32	Processing errors significance flag (1 or 0).  1 if the percentage of DSR free of processing errors is less than the acceptable threshold		1	uc
	newline character	terminator	1	uc
	<b>L1B_PROCESSING_QUALITY=</b>	keyword	23	23*uc
#33	Percentage of quality checks successfully passed during Level 1B processing (max allowed +10000)	[10-2 %]	6	%+06d
	<10-2%>	units	7	7*uc
	newline character	terminator	1	uc
	<b>L1B_PROC_THRESH=</b>	keyword	16	16*uc
	Minimum acceptable percentage of quality threshold that must be passed during Level 1B processing (max allowed +10000)	[10-2 %]	6	%+06d
#34	<10-2%>	units	7	7*uc
	newline character	terminator	1	uc
	<b>Spare (blank characters)</b>	ascii	50	50*uc
	newline character	terminator	1	uc
	<b>TOTAL</b>			
<i>DSD Section</i>				

**Table 2.3.2-1 Product SPH Description**

The DSD Section shall actually be divided in two principal sections, Measurement DSD, indicated as DSD (M) and Reference DSD, indicated as DSD (R). The general structure of a DSD is shown in table 2.3.2-2. The size of a DSD is 280 bytes.



#N	<i>DSD</i>			
#N.1	<b>DS_NAME=</b>	keyword	8	8*uc
	quotation mark		1	uc
	Name describing the Data Set		28	28*uc
	quotation mark		1	uc
	newline character	terminator	1	uc
#N.2	<b>DS_TYPE=</b>	keyword	8	8*uc
	Type of Data Set. It can be:  M = Measurement R = Reference		1	uc
	newline character	terminator	1	uc
	<i>External product reference</i>			
#N.3	<b>FILENAME=</b>	keyword	9	9*uc
	quotation mark		1	uc
	Name of the Reference File.  Used if DS_TYPE is set to R. It is left justified with trailer blanks. The file name includes the extension. If not used it is set to 62 blanks.		62	62*uc
	quotation mark		1	uc
	newline character	terminator	1	uc
	<i>Position and size of DS</i>			
#N.4	<b>DS_OFFSET=</b>	keyword	10	10*uc
	Length in bytes of MPH + SPH (including DSDs) + DS size of previous Data Set (if any).	byte	21	%+021d
	<bytes>	units	7	7*uc
	newline character	terminator	1	uc
#N.5	<b>DS_SIZE=</b>	keyword	8	8*uc
	Length in bytes of the attached Data Set Used if DS_TYPE is set to M If not used set to 0	byte	21	%+021d
	<bytes>	units	7	7*uc
	newline character	terminator	1	uc

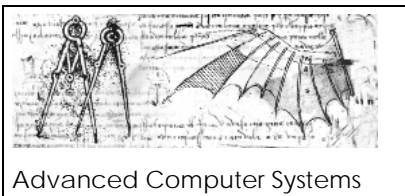

<i>Number and length of DSRs</i>				
<b>#N.6</b>	<b>NUM_DSR=</b>	keyword	8	8*uc
	Number of Data Set Records		11	%+011d
	newline character	terminator	1	uc
<b>#N.7</b>	<b>DSR_SIZE=</b>	keyword	9	9*uc
	Length in bytes of the Data Set Record If not used set to +0 If variable set to -1	byte	11	%+011d
	<bytes>	units	7	7*uc
	newline character	terminator	1	uc
<b>#N.8</b>	<b>Spare</b>	ascii	32	32*uc
	newline character	terminator	1	uc

**Table 2.3.2-2 Generic DSD Description**

A variable number of DSDs will compose the SPH. Variability in fact depends most on the number of auxiliary files and input Level 0 files effectively used to generate the product.

For convenience Measurement DSDs (1 or more) should appear first in the list, followed by all the needed Reference DSDs.

The effective size of the SPH in number of bytes is defined in field #37 SPH\_SIZE of the MPH.

The total number of DSD Descriptors is defined in field #38 of the MPH.

The number of Measurement DSDs is defined in field 40 of the MPH.

For the Measurement Data Sets the DSD 1 (M) may have the following options for the DS\_NAME:

<i>DS_NAME for DSD 1 (M)</i>
SIR_FBR_SAR
SIR_FBR_SARIN

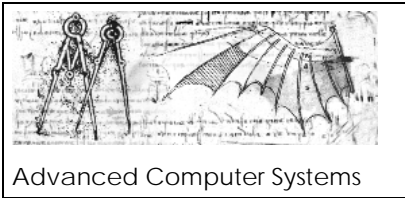

SIR_L1B_SAR
SIR_L1B_SARIN
SIR_L1B_LRM
SIR_L1B_FDM
SIR_CAL1_LRM
SIR_CAL1_SAR
SIR_CAL1_SARIN
SIR_COMPLEX_CAL1_SARIN
SIR_CAL2_SAR
SIR_CAL2_SARIN
SIR_LRM_OM
SIR_SAR_OM
SIR_SIN_OM
SIR_CAL4_OM

**Table 2.3.2-3 DS Names for Measurement Data Sets DSD 1**

The DSD 2 (M) may have the following options for the DS\_NAME:

<i>DS_NAME for DSD 2 (M)</i>
SIR_CAL1_LRM_INTERP_COR
SIR_CAL1_SAR_INTERP_COR
SIR_CAL1_SIN_INTERP_COR

**Table 2.3.2-4 DS Names for Measurement Data Sets DSD 2**

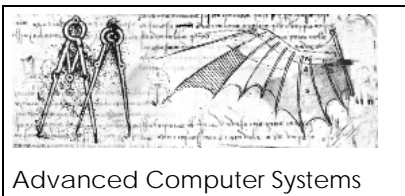

Advanced Computer Systems



Instrument Processing Facility L1b

Doc. No.: CS-RS-ACS-GS-5106  
 Issue: 4.6  
 Date: 15/09/2009  
 Page: 45

For the Reference DSDs the possible DS\_NAME are hereafter listed. For a given DS\_NAME one or more Reference DSDs may be in the final layout of the DSD if more than one file was used to generate the product. Identification of the specific file will be possible through the field #N.3 FILENAME.

<i>DS_NAME for DSD (R)</i>	
CONSTANTS_FILE	Constants File
PROC_CONFIG_PARAMS_FILE	Processor Configuration Parameters File
SIRAL_LEVEL_0_FILE	SIRAL LEVEL 0 File from which the product was created
SCENARIO_FILE	Orbit Scenario File
ORBIT_FILE	Orbit Data File
STAR_TRACKER_LEVEL_0_FILE	Star Tracker Level 0 File
DORIS_USO_DRIFT_FILE	DORIS USO Drift File
FOS_PLATFORM_DATA_FILE	FOS Platform Data File
FOS_HK_TM_FILE	FOS Sorted HouseKeeping Telemetries File
IPF_RA_DATABASE_FILE	Instrument Characterisation Data File
CALIBRATION_TYPE_1_FILE	File Product containing CAL_1 corrections
CALIBRATION_TYPE_2_FILE	File Product containing CAL_2 corrections
SIR_COMPLEX_CAL1_SARIN	File Product containing Complex CAL1 SARIN corrections
OCEAN_TIDE_FILE	File for Ocean Tide
TIDAL_LOADING_FILE	File for Tidal Loading
EARTH_TIDE_FILE	CartWright File
POLE_TIDE_FILE	Pole Location Data File
SURFACE_TYPE_FILE	Surface Type Map File
S1S2_PRESSURE_00H_MAP	Climatology Pressure Grids for each month at 00 hh.
S1S2_PRESSURE_06H_MAP	Climatology Pressure Grids for each month at 06 hh.
S1S2_PRESSURE_12H_MAP	Climatology Pressure Grids for each month at 12 hh.
S1S2_PRESSURE_18H_MAP	Climatology Pressure Grids for each month at 18 hh.
S1_TIDE_AMPLITUDE_MAP	S1 tide grid of monthly mean of global amplitude
S2_TIDE_AMPLITUDE_MAP	S2 tide grid of monthly mean of global amplitude
S1_TIDE_PHASE_MAP	S1 tide grid of monthly mean of global phase
S2_TIDE_PHASE_MAP	S2 tide grid of monthly mean of global phase
MODIFIED_DIP_MAP_FILE	Modified Dip Map File used for BENT Ionospheric Correction
IONO_COEFFICIENTS_FILE	Ionospheric Coefficients file used for BENT Ionospheric Correction
SAI_FILE	Solar Activity Index File used for BENT Ionospheric Correction
GPS_IONO_MAP	GPS Ionospheric Map Data
SURFACE_PRESSURE_FILE	Surface Pressure File for Meteo Correction
MEAN_PRESSURE_FILE	Mean Pressure File for Meteo Correction
WET_TROPOSPHERE_FILE	Wet Troposphere File for Meteo Correction
MOG_2D_FILE	2D Gravity Wave model for Dynamic Atmospheric Correction
U_WIND_FILE	U Wind component File for Meteo Correction
V_WIND_FILE	V Wind component File for Meteo Correction
METEO_GRID_DEF_FILE	Meteo Grid Definition File

Table 2.3.2-5 DS Names for Reference DSDs

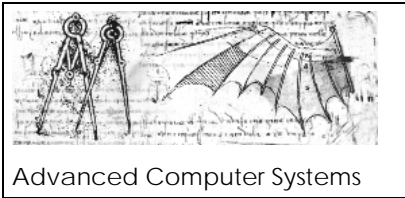

### 2.3.3 FBR SAR/SARin MDS Record Structure

The structure of this MDS is as follows:

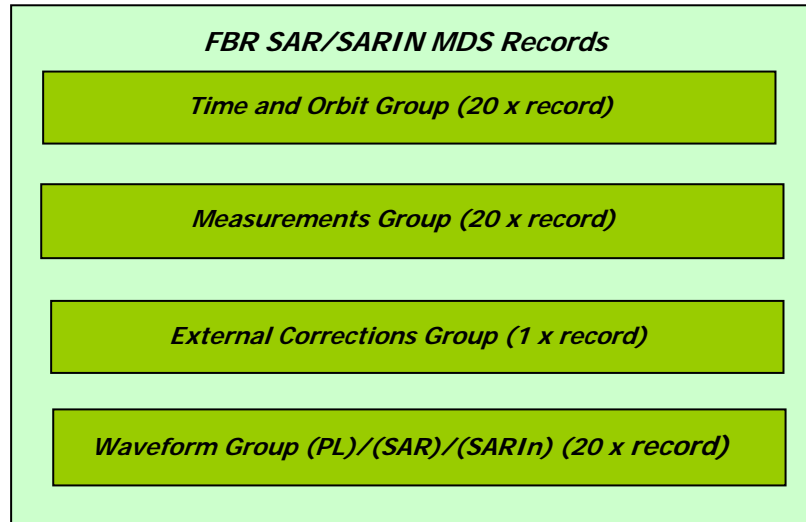

The (SAR) and (SARin) waveform group are exclusive one of the other while all the previous groups are in common.



Field	Description	Units	Bytes	Format
<b>Mode - Time and Orbit Group</b>				
1	Data Record Time (MDSR Time Stamp)	TAI	12	sl+2*ul
2	USO Correction Factor (ratio)	10 <sup>-9</sup>	4	sl
3	Mode ID		2	us (see table 2.3.3-2)
4	Source Sequence Counter		2	us (see note 6)
5	Instrument Configuration		4	ul (see table 2.3.3-3)
6	Burst counter (always starts from 1 and incremented at group rate)		4	ul
7	Latitude of measurement	10 <sup>-1</sup> μdeg	4	sl (see note 1)
8	Longitude of measurement	10 <sup>-1</sup> μdeg	4	sl (see note 1)
9	Altitude of COG above reference ellipsoid (interpolated value)	mm	4	sl
10	Instantaneous altitude rate derived from orbit	mm/s	4	sl
11	Satellite velocity vector[3] (in ITRF)	mm/s	3*4	sl
12	Real beam direction vector[3] (in CRF)	μm	3*4	sl
13	Interferometer baseline vector[3] (in CRF)	μm	3*4	sl
14	FBR Measurement Confidence Data (flag word)		4	ul (see table 2.3.3-4)
<b>Measurements Group</b>				
15	Window Delay (2way) uncorrected for instrument delays	10-12 s	8	sl
16	Ho Initial Height Word	48.8 ps	4	sl (see note 2)
17	COR2 Height Rate	3.05 ps/rc	4	sl (see note 2)
18	Coarse Range Word LAI	12.5 ns	4	sl (see note 2)
19	Fine Range Word FAI	12.5/256 ns	4	sl (see note 2)
20	AGC_1 (not corrected)	dB/100	4	sl (see note 3)
21	AGC_2 (not corrected)	dB/100	4	sl (see note 3)
22	Total Fixed Gain Rx 1	dB/100	4	sl (see note 3)
23	Total Fixed Gain Rx 2	dB/100	4	sl (see note 3)
24	Transmit Power	Micro-Watts	4	sl
25	Doppler range correction (Radial component)	mm	4	sl
26	Instrument Range Correction tx-rx antenna (from CAL1)	mm	4	sl
27	Instrument Range Correction	mm	4	sl



	rx only antenna (from CAL1)			
28	Instrument Gain correction, tx-rx antenna (from CAL1)	dB/100	4	sl (see note 3)
29	Instrument Gain correction rx only antenna (from CAL1)	dB/100	4	sl (see note 3)
30	Internal Phase Correction	Microradians	4	sl
31	External Phase Correction	Microradians	4	sl
32	Noise power measurement	dB/100	4	sl (see note 3)
33	Phase Slope Correction	Microradians	4	sl
34	Spares		4*1	uc
<b>Corrections Group</b>				
35	Dry Tropospheric Correction	mm	4	sl
36	Wet Tropospheric Correction	mm	4	sl
37	Inverse Barometric Correction	mm	4	sl
38	Dynamic Atmospheric Correction	mm	4	sl
39	GIM Ionospheric Correction	mm	4	sl
40	Model Ionospheric Correction	mm	4	sl
41	Ocean Equilibrium Tide	mm	4	sl
42	Long Period Tide Height	mm	4	sl
43	Ocean Loading Tide	mm	4	sl
44	Solid Earth Tide	mm	4	sl
45	Geocentric Polar Tide	mm	4	sl
46	Surface type flag	-	4	ul
47	Spare	-	4*1	uc
48	Correction status flags		4	ul (see table 2.3.3-5)
49	Correction error flags		4	ul (see table 2.3.3-6)
50	Spare		4*1	uc
Sub-Total Size			3424 bytes	

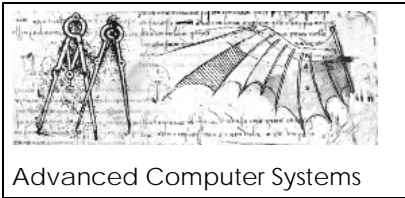

Waveform group (SAR)				
51	Complex Echo Waveform[64,128,2]		64*128*2	sc (see note 5)
52	Number of pulses in burst		2	us
53	Flag		2	us
Sub-Total Size			327760 bytes	
Total Record Size			331184 bytes	

Waveform group (SARin)				
54	Complex Echo Waveform[64,512,2] antenna 1 (Tx-Rx)		64*512*2	sc (see note 5)
55	Complex Echo Waveform[64,512,2] antenna 2 (Rx only)		64*512*2	sc (see note 5)
56	Number of pulses in burst		2	us
57	Flag		2	us
Sub-Total Size			2621520 bytes	
Total Record Size			2624944 bytes	

**Table2.3.3-1: FBR MDS Records**

Notes:

- 1) this is an exotic unit exclusively used at binary record level to improve resolution of the lat and long fields
- 2) These are exotic units specific of SIRAL instrument
- 3) This is an exotic unit used for db-units related fields.
- 5) Complex echo samples are packed in bytes for both SAR and SARIN, The "Q" byte is followed by the "I" byte.
- 6) The field Source Sequence Counter is copied – from ECHO-SAR L0 –first packet of group for FBR SAR – ECHO-SARIN L0 of Master channel, first packet of group, for FBR SARIN.

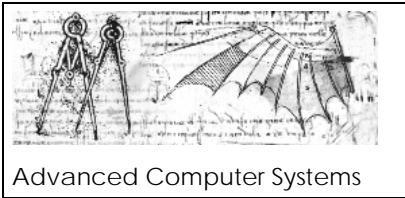

**Fields Descriptions:**

Field 1) MDSR Time Stamp - corresponding to ground bounce time of the individual pulse, or middle of group of pulses for LRM.

Field 2) USO Correction factor - this is the correction factor for USO drift defined as the ratio between the nominal and the measured value.

Field 3) Mode ID - (us giving 16 bits) Identifies the SIRAL instrument measurement mode. See Table 2.3.3-2:

ID	Definition	Bit (*)	Bit (**)	Setting
1.	Instrument Operative Mode	15-10	0-5	1 = LRM 2 = SAR 3 = SARIN  11 = CAL1-LRM 12 = CAL1-SAR 13 = CAL1-SARIN  22 = CAL2-SAR 23 = CAL2-SARIN
2.	SARIn Degraded Case	9	6	0 : Nominal SARIN Scenario 1: Contingency SARIN Scenario (1 Rx chain missing)
3.	Reserved	8	7	Set to zero
4.	CAL4 Flag	7	8	1 if CAL4 packets detected
5	Platform Attitude Control	6-5	9-10	0 = Unknown 1 = Local Normal Pointing 2 = Yaw Sterring
6.	Reserved	4-0	11-15	Set to zero

(\*) Ground Segment bit numbering standard [FMT-Guide]

(\*\*) Space Segment bit numbering standard

**Table 2.3.3-2: Mode\_ID**



Field 4) Source Sequence Counter - read from the L0 Echo telemetry packet (of the master channel in the case of SARin). This is a 16384 cyclic modulo counter, starting from 0, incrementing by 1. A separate counter is maintained for each instrument mode.

Field 5) Instrument Config flag - this is derived from flags in the L0 packets for tracking and the echo telemetry. see Table 2.3.3-3:

ID	Definition	Bit (*)	Bit (**)	Setting
1.	Rx chain in use	31-30	0-1	1 = Rx1 2 = Rx2 3 = Both 0 = Unknown
2.	SIRAL_Identifier	29	2	0 = Nominal 1 = Redundant
3.	Reserved	28	3	Set to zero
4.	Bandwidth	27-26	4-5	1 = 320 Mhz 2 = 40 Mhz 0 = Unknown
5.	Reserved	25-24	6-7	Set to zero
6.	Tracking Mode	23-22	8-9	1 = LRM 2 = SAR 3 = SARIN 0 = Unknown
7.	External Calibration	21	10	0 = no 1 = External Calibration
8.	Reserved	20	11	Set to zero
9.	Loop Status	19	12	0 = closed loop 1 = open loop
10.	Loss of Echo (from Cycle Report)	18	13	0 = OK 1 = Loss of Echo
11.	Real Time Error (from Cycle Report)	17	14	0 = OK 1 = Real Time Computation Error
12.	Echo Saturation Error (from Cycle Report)	16	15	0 = OK 1 = Echo Saturation Error
13.	Rx Band Attenuation	15	16	0 = not applied 1 = applied
14.	Cycle Report General Error	14	17	0 = Cycle Report is 0 1 = Cycle Report is not 0

15.	Star Tracker 1 used	13	18	Set to 1 if Star Tracker 1 is used
16.	Star Tracker 2 used	12	19	Set to 1 if Star Tracker 2 is used
17.	Star Tracker 3 used	11	20	Set to 1 if Star Tracker 3 is used
18.	Reserved	10-0	21-31	Set to zero

(\*) Ground Segment bit numbering standard [FMT-Guide]

(\*\*) Space Segment bit numbering standard

**Table 2.3.3-3: Instrument Config**

Field 6) High-rate block counter - will increment from 1 for each data block. Hence the first full MDS record will contain the numbers 1-20, the second 21-40, etc.

Field 7) Latitude of measurement - corresponding to the MDSR Time Stamp.

Field 8) Longitude of measurement - corresponding to the MDSR Time Stamp.

Field 9) Altitude - altitude of the Satellite CoM above reference ellipsoid corresponding to the MDSR Time Stamp.

Field 10) Altitude rate - (as for Latitude)

Field 11) Satellite velocity vector -described in the International Terrestrial Reference Frame in the International Earth Fixed System. From Orbit CFI call. This is not a unit vector as the velocity magnitude is also required.

Field 12) Real beam direction vector - described in the Cryosat Reference Frame. This is a unit vector and note that the units are micro-metres.

Field 13. Interferometric baseline vector - described in the Cryosat Reference Frame. This is a unit vector and note that the units are micro-metres.

Field 14. FBR MCD - Measurement confidence flags. Generally the MCD flags indicate problems when set. If the whole MCD is 0 then no problems or non-nominal conditions were detected. Serious errors (highlighted in the table) are indicated by setting bit 31 (SS bit 0). In which case the block must not be processed. Other error settings can be regarded as warnings. See table 2.3.3-4:



ID	Definition	Bit (*)	Bit (**)	Setting
1.	<b>Block Degraded</b>	31	0	0 = OK 1 = Degraded (set if the block should not be processed – indicated by <b>bold</b> typeface & shading)
2.	<b>Blank Block</b>	30	1	0 = OK 1 = Blank Block inserted for record padding
3.	<b>Datation Degraded</b>	29	2	0 = OK 1 = Datation is bad or not set
4.	Orbit Propagation Error	28	3	0 = OK 1 = Error (returned by CFI or independent check)
5.	Orbit File Change	27	4	0 = OK 1 = Orbit file has changed wrt previous record
6.	Orbit Discontinuity	26	5	0 = OK 1 = discontinuity (e.g. gap)
7.	Echo Saturation (from Cycle Report)	25	6	0 = OK 1 = Saturated
8.	Other Echo Error	24	7	0 = OK 1 = Echo Error (bit fields Tracking Echo Error or Echo Rx1 Error or Echo Rx2 Error set to 1)
9.	Rx 1 Channel Error for SARIN	23	8	0 = OK 1 = degraded or missing
10.	Rx 2 Channel error for SARIN	22	9	0 = OK 1 = degraded or missing
11.	<b>Window Delay Inconsistency</b>	21	10	0 = OK (value is in range) 1 = value out of range or computation error
12.	<b>AGC Inconsistency</b>	20	11	0 = OK (value is in range) 1 = value out of range or computation error
13.	Cal1 Correction Missing	19	12	0 = correction applied 1 = correction not applied
14.	Cal1 Correction from IPF DB	18	13	0 = correction from CAL1 Product used 1 = correction from IPF DB used
15.	DORIS USO Correction	17	14	0 = USO Correction Factor is

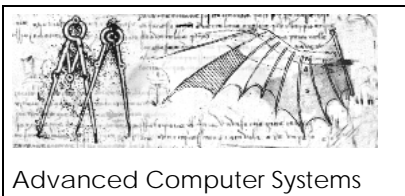

				available 1 = USO Correction Factor is not available
16.	Complex Cal1 Correction from IPF DB	16	15	0 = correction from Complex CAL1 Product used 1 = correction from IPF DB used
17.	TRK Echo Error	15	16	0 = OK 1 = empty (or null) tracking echo
18.	Echo Rx 1 Error	14	17	0 = OK 1 = empty (or null) raw echo
19.	Echo Rx2 Error	13	18	0 = OK 1 = empty (or null) raw echo
20.	NPM Inconsistency	12	19	0 = OK 1 = value out of range or computation error
21	Reserved	11-4	20-27	Set to zero
22.	Attitude Correction Missing	3	28	0 = OK, attitude correction applied 1 = missing, correction not applied.
23.	Reserved	2-0	29-31	Set to zero

(\*) Ground Segment bit numbering standard [FMT-Guide]

(\*\*) Space Segment bit numbering standard

**Table 2.3.3-4: FBR Measurement Confidence Data**

Field 15) Window delay - The window delay from the telemetry converted to physical units. This is a 2-way measurement: the time taken for the radar pulse to travel to the surface and back.

Field 16) H0 - from telemetry

Field 17) COR2 - on-board tracker height rate over the radar cycle

Field 18) Coarse range word LAI - derived from telemetry

Field 19) Fine range word - derived from telemetry

Field 20) AGC1 - First AGC stage setting (applies to both receive channels) from telemetry. The value is commanded on board, from the tracker loop in normal operation. Gain calibration corrections are not applied. Note: the value is always an integer number of dB but units of db/100 are used to be consistent.

Field 21) AGC2 - Second AGC stage setting (applies to both receive channels) from telemetry

Field 22) Total Fixed Gain On Channel 1 - total fixed instrument gain applied on chain 1, this is the gain applied by the RF unit. see [R21] for details.

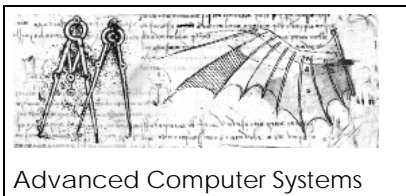

Field 23) Total Fixed Gain On Channel 2 - instrument fixed gain on receive chain 2 (as for chain 1)

Field 24) Transmit power in micro Watts.

Field 25) Doppler range correction - computed for the component of satellite velocity in the nadir direction.

Field 26) Instrument Range Correction (Tx-Rx chain) - Calibration correction to range on channel 1 computed from CAL1. (CAL1-LRM, CAL1-SAR and CAL1-SARin)

Field 27) Instrument Range Correction (Rx only chain) - Calibration correction to range on channel 2 computed from CAL1. (CAL1-LRM, CAL1-SAR and CAL1-SARin)

Field 28) Instrument Gain Correction (t-r chain) - Calibration correction to gain on channel 1 computed from CAL1. (Sometimes referred to as 'Sigma0 correction')

Field 29) Instrument Gain Correction (r only chain) - Calibration correction to gain on channel 2 computed from CAL1.

Field 30) Internal phase correction. - set to zero due to no availability of correction until specialized FBR-L1B processing

Field 31) External phase correction. - set to zero since correction has no meaning at FBR level

Field 32) Noise power measurement - converted from telemetry units to be the noise floor of FBR measurement echoes

Field 33) Phase Slope Correction – set to zero since correction has no meaning at FBR level

Field 34) measurement spares - reserved for future use.

Field 35) Dry Tropospheric Correction - added to range measurement to correct for the propagation delay to the radar pulse, caused by the dry-gas component of the Earth's atmosphere.

Field 36) Wet Tropospheric Correction - added to range measurement to correct for the propagation delay to the radar pulse, caused by the H2O component of the Earth's atmosphere.

Field 37) Inverse Barometric Correction - added to range measurement to correct for the depression of the ocean surface caused by the local barometric pressure.

Field 38) Dynamic Atmospheric Correction - added to range measurement to correct for high frequency variability of the atmosphere

Field 39) GIM Ionospheric Correction - added to range measurement to correct for the delay to the Radar pulse caused by free electrons in the ionosphere. Computed from GPS ionospheric data.

Field 40) Model Ionospheric Correction - added to range measurement to correct for the delay to the Radar pulse caused by free electrons in the ionosphere. Computed from an Ionospheric model.



Advanced Computer Systems



*Instrument Processing Facility L1b*

Doc. No.: *CS-RS-ACS-GS-5106*  
Issue: *4.6*  
Date: *15/09/2009*  
Page: *56*

Field 42) Ocean Tide - to be added to the range to remove the effect of local tide and adjust the measurement to the mean sea surface.

Field 42) Long-Period equilibrium Ocean Tide - a component of total ocean tide. To be added to range to correct for the tidal effect.

Field 43) Ocean Loading Tide - added to the range to remove the effect of local tidal distortion to the Earth's crust.

Field 44) Solid Earth Tide - added to the range to remove the effect of local tidal distortion in the Earth's crust.

Field 45) Geocentric Polar Tide - added to the range to remove the effect of movement of the Earth's rotational axis w.r.t. geographic location.

Field 46) Surface type flag - enumerated key to classify surface at nadir:

- 0 = Open Ocean
- 1 = Closed Sea
- 2 = Continental Ice
- 3 = Land

Field 47) Correction spares - reserved for future use.

Field 48) Correction status flag - used to show which correction algorithms have been called, see Table 2.3.3-5.

Field 49) Correction error flag - used to show if a correction algorithms returned an error when called, see Table 2.3.3-6.

Field 50) Correction spares - reserved for future use.

ID	Definition	Bit (*)	Bit (**)	Setting
1.	Dry Tropospheric Correction Called	31	0	0 = no, 1 = yes
2.	Wet Tropospheric Correction Called	30	1	0 = no, 1 = yes
3.	Inverse Barometric Correction Called	29	2	0 = no, 1 = yes
4.	DAC correction Called	28	3	0 = no, 1 = yes
5.	GIM Ionospheric Correction Called	27	4	0 = no, 1 = yes
6.	Model Ionospheric Correction Called	26	5	0 = no, 1 = yes
7.	Ocean Equilibrium Tide Called	25	6	0 = no, 1 = yes
8.	Ocean Long Period Tide Called	24	7	0 = no, 1 = yes
9.	Ocean Loading Tide Called	23	8	0 = no, 1 = yes
10.	Solid Earth Tide Called	22	9	0 = no, 1 = yes
11.	Geocentric Polar Tide Called	21	10	0 = no, 1 = yes
12.	Surface type flag Called	20	11	0 = no, 1 = yes
13.	reserved	19-0	10-31	set to 0

(\*) Ground Segment bit numbering standard [FMT-Guide]

(\*\*) Space Segment bit numbering standard

**Table 2.3.3-5: Correction status flags**

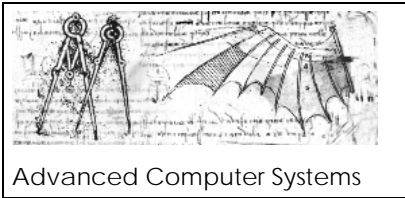

ID	Definition	Bit (*)	Bit (**)	Setting
1.	Dry Tropospheric Correction Error	31	0	0 = OK, 1 = error
2.	Wet Tropospheric Correction Error	30	1	0 = OK, 1 = error
3.	Inverse Barometric Correction Error	29	2	0 = OK, 1 = error
4.	Dynamic Atmospheric Correction Error	28	3	0 = OK, 1 = error
5.	GIM Ionospheric Correction Error	27	4	0 = OK, 1 = error
6.	Model Ionospheric Correction Error	26	5	0 = OK, 1 = error
7.	Ocean Equilibrium Tide Error	25	6	0 = OK, 1 = error
8.	Ocean Long Period Tide Error	24	7	0 = OK, 1 = error
9.	Ocean Loading Tide Called	23	8	0 = OK, 1 = error
10.	Solid Earth Tide Called	22	9	0 = OK, 1 = error
11.	Geocentric Polar Tide Called	21	10	0 = OK, 1 = error
12.	Surface type flag Error	20	11	0 = OK, 1 = error
13.	reserved	19-0	12-31	set to 0

(\*) Ground Segment bit numbering standard [FMT-Guide]

(\*\*) Space Segment bit numbering standard

**Table 2.3.3-6: Correction error flags**

- Waveform Group for SAR Mode

Field 51) Complex Echo Waveform - Array of 64 echoes \* 128 bins \* 2 for I & Q samples. These are stored as signed characters, as they were in the telemetry.

Field 52) Number of echoes in burst - normally 64. If lower some of the echoes in field 51. will be filled with zeroes.

Field 53) Flags - for errors or information about echoes. Currently not used – Reserved for future use.

- Waveform Group for SARin Mode

Field 54) Complex Echo Waveform antenna 1- Array of 64 echoes \* 512 bins \* 2 for I & Q samples. These are stored as signed characters, as they were in the telemetry.

Field 55) Complex Echo Waveform antenna 1- Array of 64 echoes \* 512 bins \* 2 for I & Q samples. These are stored as signed characters, as they were in the telemetry.

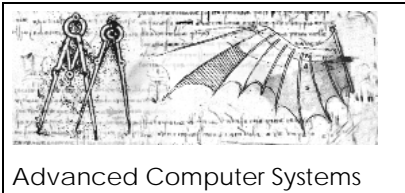

Advanced Computer Systems



*Instrument Processing Facility L1b*

Doc. No.: *CS-RS-ACS-GS-5106*  
Issue: *4.6*  
Date: *15/09/2009*  
Page: *59*

Field 56) Number of echoes in burst - normally 64. If lower some of the echoes in field 51. will be filled with zeroes.

Field 57) Flags - for errors or information about echoes. Currently not used – Reserved for future use.

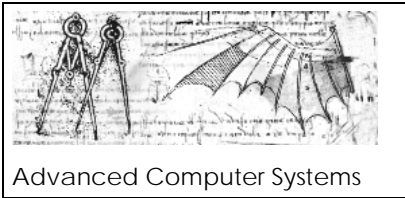

### 2.3.4 L1b LRM(FDM<sup>1</sup>)/SAR/SARin Data Products MDS Record Structure

This MDS is composed by:

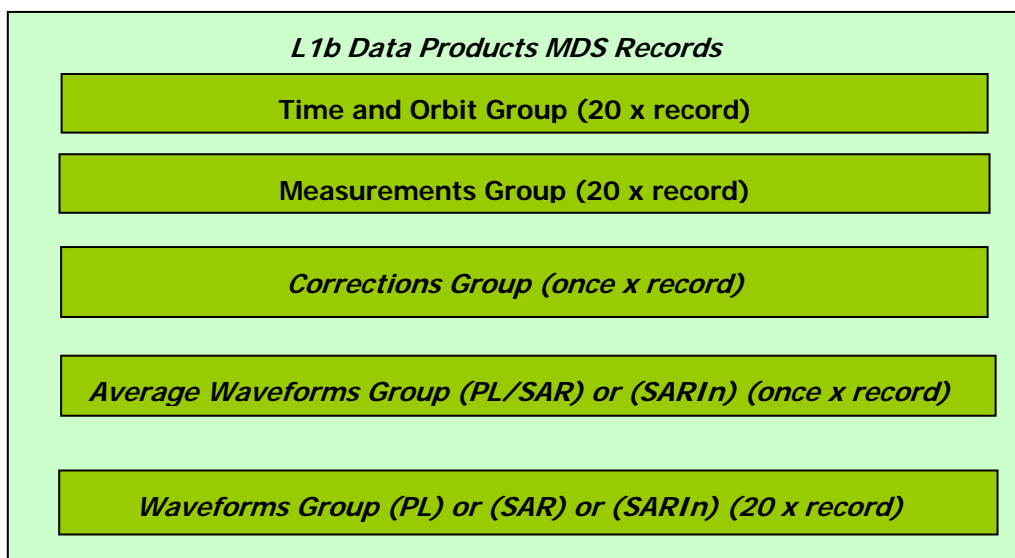

The L1b MDS has actually three variations depending on the Mode. The data record is arranged so that the first part is common to all modes. Time and Orbit Group and Measurements Group are in blocks of 20 per record. Corrections are made available once per record. The common part is then followed by:

- a 1 Hz averaged waveform
- a set of 20 Waveforms

Waveforms are mode dependent and thus specific layouts are defined.

---

<sup>1</sup> Fast Delivery Ocean (FDM) product is produced for LRM mode data only and is run as soon as possible after acquisition. The FBR and L1B FDM products have the same record structure as LRM



Field	Description	Units	Bytes	Format
<b>Time and Orbit Group (structure repeated 20 times per record)</b>				
1	Data Record Time (MDSR Time Stamp)	TAI	12	sl+2*ul
2	USO Correction Factor (Ratio)	10 <sup>-9</sup>	4	sl
3	Mode ID	-	2	us (see table 2.3.3-2)
4	Source Sequence Counter (only for LRM – Spare in SAR & SARIN)		2	us
5	Instrument Configuration		4	ul (see table 2.3.3-3)
6	Burst counter (surface sample counter) (always starts from 1 and incremented at group rate)	-	4	ul
7	Latitude of measurement	10 <sup>-1</sup> μdeg	4	sl (see note 1)
8	Longitude of measurement	10 <sup>-1</sup> μdeg	4	sl (see note 1)
9	Altitude of COG above reference ellipsoid (interpolated value)	mm	4	sl
10	Instantaneous altitude rate derived from orbit	mm/sec	4	sl
11	Satellite velocity vector[3] (in ITRF)	mm/s	3*4	sl
12	Real beam direction vector[3] (in CRF)	μm	3*4	sl
13	Interferometer baseline vector[3] (in CRF)	μm	3*4	sl
14	Level 1b Measurement Confidence Data (flag word)	-	4	ul (see table 2.3.4-2)
<b>Measurements Group (structure repeated 20 times per record)</b>				
15	Window Delay (2way) corrected for instrument delays	10-12 s	8	sll
16	Ho Initial Height Word	48.8 ps	4	sl (see note 2)
17	COR2 Height Rate	3.05 ps/rc	4	sl (see note 2)
18	Coarse Range word LAI	12.5 ns	4	sl (see note 2)
19	Fine Range word FAI	12.5/256 ns	4	sl (see note 2)
20	AGC Channel 1 (corrected)	dB/100	4	sl (see note 3)
21	AGC Channel 2 (corrected)	dB/100	4	sl (see note 3)
22	Total Fixed Gain Rx 1	dB/100	4	sl (see note 3)
23	Total Fixed Gain Rx 2	dB/100	4	sl (see note 3)
24	Transmit Power	Micro-Watts	4	sl
25	Doppler range correction (Radial component)	mm	4	sl
26	Instrument Range Correction tx-rx antenna	mm	4	sl
27	Instrument Range Correction rx only antenna	mm	4	sl



28	Instrument Gain correction tx-rx antenna	dB/100	4	sl (see note 3)
29	Instrument Gain correction rx only antenna	dB/100	4	sl (see note 3)
30	Internal Phase Correction	Microradians	4	sl
31	External Phase Correction	Microradians	4	sl
32	Noise power measurement	dB/100	4	sl (see note 3)
33	Phase Slope Correction	Microradians	4	sl
34	Spares		4*1	uc
<b>Corrections Group (once per record)</b>				
35	Dry Tropospheric Correction	mm	4	sl
36	Wet Tropospheric Correction	mm	4	sl
37	Inverse Barometric Correction	mm	4	sl
38	Dynamic Atmospheric Correction	mm	4	sl
39	GIM Ionospheric Correction	mm	4	sl
40	Model Ionospheric Correction	mm	4	sl
41	Ocean Tide	mm	4	sl
42	Long Period Tide Height	mm	4	sl
43	Ocean Loading Tide	mm	4	sl
44	Solid Earth Tide	mm	4	sl
45	Geocentric Polar Tide	mm	4	sl
46	Surface type flag	-	4	ul
47	Spare	-	4*1	uc
48	Correction status flags	-	4	ul (see Table 2.3.3-5)
49	Correction error flags	-	4	ul (see Table 2.3.3-6)
50	Spare		4*1	uc
Sub-Total Size			3424 bytes	

Field	Descriptor	Unit	Bytes	Format
<b>Average Waveform group: PL/SAR (once per record)</b>				
51	Data Record Time (MDSR Time Stamp)	TAI	12	sl+2*ul
52	Latitude of measurement	10 <sup>-1</sup> μdeg	4	sl (see note 1)
53	Longitude of measurement	10 <sup>-1</sup> μdeg	4	sl (see note 1)
54	Altitude of COG above reference ellipsoid (interpolated value)	mm	4	sl
55	Window Delay (2way) corrected for instrument delays	10-12 s	8	sll
56	1 Hz Averaged Power Echo Waveform[128]	Scaled	128*2	us
57	Echo Scale Factor (to scale echo to watts)	-	4	sl

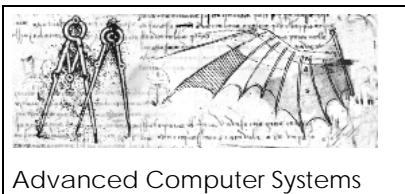

58	Echo Scale Power (a power of 2)		4	sl
59	Number of echoes averaged	-	2	us
60	Flags	-	2	us (see Table 2.3.4-3/4)
Sub-Total Size			300 bytes	

Field	Descriptor	Unit	Bytes	Format
<b>Average Waveform group: SARIN (once per record)</b>				
61	Data Record Time (MDSR Time Stamp)	TAI	12	sl+2*ul
62	Latitude of measurement	10 <sup>-1</sup> μdeg	4	sl (see note 1)
63	Longitude of measurement	10 <sup>-1</sup> μdeg	4	sl (see note 1)
64	Altitude of COG above reference ellipsoid (interpolated value)	mm	4	sl
65	Window Delay (2way) corrected for instrument delays	10-12 s	8	sll
66	1 Hz Averaged Power Echo Waveform[512]	Scaled	512*2	us
67	Echo Scale Factor (to scale echo to watts)	-	4	sl
68	Echo Scale Power (a power of 2)		4	sl
69	Number of echoes averaged	-	2	us
70	Flags	-	2	us
Sub-Total Size			1068 bytes	

Field	Descriptor	Unit	Bytes	Format
<b>Waveform group: PL (structure repeated 20 times per record)</b>				
71	Averaged Power Echo Waveform[128]	Scaled	128*2	us
72	Echo Scale Factor (to scale echo to watts)	-	4	sl
73	Echo Scale Power (a power of 2)		4	sl
74	Number of echoes averaged	-	2	us
75	Flags	-	2	us
Sub-Total Size			5360 bytes	
<b>Total Record Size</b>			<b>9084 bytes</b>	

Field	Descriptor	Unit	Bytes	Format
<b>Waveform group: SAR (structure repeated 20 times per record)</b>				

76	Averaged Power Echo Waveform [128]	Scaled	128*2	us
77	Echo Scale Factor (to scale echo to watts)	-	4	sl
78	Echo Scale Power (a power of 2)		4	sl
79	Number of echoes averaged	-	2	us
80	Flags	-	2	us
81	Beam behaviour parameter [50]	-	50*2	ss (see table 2.3.4-5)
Sub-Total Size			7360 bytes	
<b>Total Record Size</b>			<b>11084 bytes</b>	

Field	Descriptor	Unit	Bytes	Format
<b>Waveform group (SARin) (Structure repeated 20 times per record)</b>				
82	Averaged Power Echo Waveform[512]	Scaled	512*2	us
83	Echo Scale Factor (to scale echo to watts)	-	4	sl
84	Echo Scale Power (a power of 2)		4	sl
85	Number of echoes averaged	-	2	us
86	Flags	-	2	us
87	Beam behaviour parameter [50]		50*2	ss (see table 2.3.4-5)
88	Coherence [512]	1/1000	512*2	us
89	Phase difference [512]	microrad	512*4	sl
Sub-Total Size			84160 bytes	
<b>Total Recod Size</b>			<b>88652 bytes</b>	

**Table 2.3.4-1: L1b Data Products MDS Records**

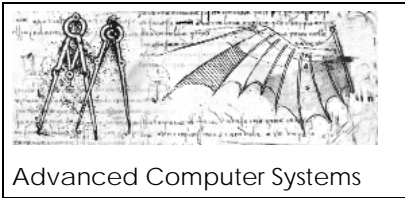

Notes:

- 1) this is an exotic unit exclusively used at binary record level to improve resolution of the lat and long fields
- 2) These are exotic units specific of SIRAL instrument
- 3) This is an exotic unit used for db-units related fields.

Field 1) MDSR Time Stamp - corresponding to ground bounce time of the individual pulse, or middle of group of pulses for LRM.

Field 2) USO Correction factor - this is the correction factor for USO drift defined as the ratio between the nominal and the measured value.

Field 3) Mode ID - Identifies the SIRAL instrument measurement mode. See table 2.3.3-2

Field 4) Source Sequence Counter - read from the L0 Echo telemetry packet (of the master channel in the case of SARin). This is a 16384 cyclic modulo counter, starting from 0, incrementing by 1. A separate counter is maintained for each instrument mode.

Field 5) Instrument Config flag - This is derived from flags in the L0 packets for tracking and the echo. see table 2.3.3-3.

Field 6) Record counter - will increment from 1 for each data block. Hence the first full MDS record will contain the numbers 1-20, the second 21-40, etc.

Field 7) Latitude of measurement - corresponding to the MDSR Time Stamp.

Field 8) Longitude of measurement - (as for Latitude)

Field 9) Altitude - altitude of the Satellite CoM above reference ellipsoid - (as for Latitude)

Field 10) Altitude rate - (as for Latitude)

Field 11) Satellite velocity vector - in International Terrestrial Reference Frame in the International Earth Fixed System.

Field 12) Real beam direction vector - described in the Cryosat Reference Frame. Unit vector in micro-metres.

Field 13) Interferometric baseline vector - Cryosat Reference Frame. Unit vector in micro-metres.

Field 14) L1B MCD - Measurement confidence flags. Generally the MCD flags indicate problems when set. If the whole MCD is 0 then no problems or non-nominal conditions were detected. Serious errors are indicated by setting bit 31 (SS bit 0). In which case the block must not be processed. Other error settings can be regarded as warnings. See table 2.3.4-2:



Advanced Computer Systems



Instrument Processing Facility L1b

Doc. No.: CS-RS-ACS-GS-5106  
 Issue: 4.6  
 Date: 15/09/2009  
 Page: 66

ID	Definition	Bit (*)	Bit (**)	Setting
1.	<b>Block Degraded</b>	31	0	0 = OK 1 = Degraded (set if the block should not be processed – indicated by <b>bold</b> typeface & shading)
2.	<b>Blank Block</b>	30	1	0 = OK 1 = Blank Block inserted for record padding
3.	<b>Datation Degraded</b>	29	2	0 = OK 1 = Datation is bad or not set
4.	<b>Orbit Propagation Error</b>	28	3	0 = OK 1 = Error (returned by CFI or independent check)
5.	Orbit File Change	27	4	0 = OK 1 = Orbit file has changed wrt previous record
6.	Orbit Discontinuity	26	5	0 = OK 1 = discontinuity (e.g. gap)
7.	Echo Saturation (from Cycle Report)	25	6	0 = OK 1 = Saturated
8.	Other Echo Error	24	7	0 = OK 1 = Echo Error (bit fields Tracking Echo Error or Echo Rx1 Error or Echo Rx2 Error set to 1)
9.	Rx 1 Channel Error for SARIN	23	8	0 = OK 1 = degraded or missing
10.	Rx 2 Channel error for SARIN	22	9	0 = OK 1 = degraded or missing
11.	<b>Window Delay Inconsistency</b>	21	10	0 = OK (value is in range)



				1 = value out of range or computation error
12.	<b>AGC Inconsistency</b>	20	11	0 = OK (value is in range) 1 = value out of range or computation error
13.	Cal1 Correction Missing	19	12	0 = correction applied 1 = correction not applied
14.	Cal1 Correction from IPF DB	18	13	0 = correction from CAL1 Product used 1 = correction from IPF DB used
15.	DORIS USO Correction	17	14	0 = USO Correction Factor is available 1 = USO Correction Factor is not available
16.	complex Cal1 Correction from IPF DB	16	15	0 = correction from Complex CAL1 Product used 1 = correction from IPF DB used
17.	TRK Echo Error	15	16	0 = OK 1 = empty (or null) tracking echo
18.	Echo Rx 1 Error	14	17	0 = OK 1 = empty (or null) raw echo
19.	Echo Rx2 Error	13	18	0 = OK 1 = empty (or null) raw echo
20.	NPM Inconsistency	12	19	0 = OK 1 = value out of range or computation error
21.	Reserved	11	20	Set to 0
22.	Reserved	10	21	Set to 0
23.	Reserved	9	22	Set to 0
24.	Reserved	8	23	Set to 0
25.	Phase Perturbation Correction application	7	24	0 = applied , 1 = not applied
26.	Cal2 Correction Missing	6	25	0 = correction applied

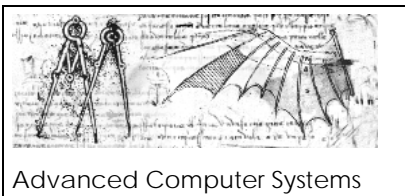

				1 = correction not applied
27.	Cal 2 Correction from IPF DB	5	26	0 = correction from CAL2 Product used 1 = correction from IPF DB used
28.	<b>Power Scaling Error (for LRM only)</b>	4	27	0 = Ok (echo has been power scaled) 1 = Error in scaling (L1B waveform is null) Used only for LRM L1B
29.	Attitude Correction Missing	3	28	0 = OK, Correction Applied 1 = Not Corrected
30.	Reserved	2	29	Set to 0
31.	reserved	1	30	Set to 0
32.	Phase Perturbation Correction mode	0	31	0 = computed by CCAL1 1 = default from IPF DB used (applicable only to SARin data)

(\*) Ground Segment bit numbering standard [FMT-Guide]

(\*\*) Space Segment bit numbering standard

**Table 2.3.4-2: L1B Measurement Confidence Data**

Field 15) Window delay - The window delay from the telemetry converted to physical units. Note that this is still a 2-way time, and so 2-way corrections are applied. COM offset is applied and Calibration correction from Cal1 is applied. Units are pico seconds.

Field 16) H0 - from telemetry

Field 17) COR2 - on-board tracker height rate over the radar cycle

Field 18) Coarse range word LAI - derived from telemetry

Field 19) Fine range word - derived from telemetry

Field 20) AGC ch 1 - AGC gain applied on Rx channel 1. Gain calibration corrections are applied. (Sum of AGC stages 1 and 2 plus the corresponding corrections)



Advanced Computer Systems



*Instrument Processing Facility L1b*

Doc. No.: CS-RS-ACS-GS-5106  
Issue: 4.6  
Date: 15/09/2009  
Page: 69

Field 21) AGC ch 2 - AGC gain applied on Rx channel 2. Gain calibration corrections are applied.

Field 22) Total Fixed Gain On Channel 1 - total fixed instrument gain applied on chain 1, this is the gain applied by the RF unit.

Field 23) Total Fixed Gain On Channel 2 - instrument fixed gain on receive chain 2 (as for chain 1)

Field 24) Transmit power in micro Watts.

Field 25) Doppler range correction - computed for the component of satellite velocity in the nadir direction.

Field 26) Instrument Range Correction (Tx-Rx chain) - Calibration correction to range on channel 1 computed from CAL1.

Field 27) Instrument Range Correction (Rx only chain) - Calibration correction to range on channel 2 computed from CAL1.

Field 28) Instrument Gain Correction (Tx-Rx chain) - Calibration correction to gain on channel 1 computed from CAL1.

Field 29) Instrument Gain Correction (Rx only chain) - Calibration correction to gain on channel 2 computed from CAL1.

Field 30) Internal phase correction. - This is the internal phase correction computed from the CAL-4 packets during the azimuth impulse response amplitude (SARIN only). It is set from the latest available CAL-4 packet.

Field 31) External phase correction. - this is an external phase correction taken from the IPFDB file (SARIN only) to be added to the internal phase correction term. This is the temperature-averaged component of external inter-channel phase difference derived from phase difference sensitive antenna subsystem, waveguides and instrument waveguide switches. It doesn't contain internal instrument temperature dependent effects of calibration coupler and duplexer which are dealt with by the CAL-4 signal, its subsequent processing and is reported in the internal phase correction parameter.

Field 32) Noise power measurement - converted from telemetry units to be the noise floor of FBR measurement echoes

Field 33) Phase Slope Correction - Differential group delay phase difference slope correction (across the whole bandwidth): fixed and variable group delays introduce a phase difference slope across the instrument bandwidth. Fixed elements of differential group delay have been determined during ground testing and characterisation and cover the elements of antenna, calibration coupler, louis XV waveguide. Variable elements cover differences between the CAL-1 and CAL-4 paths and can be.

By nature of the product SIR\_SAR\_1B and SIR\_LRM\_1B will contain this parameter but shall be set to zero.

Since the correction can only be made at the rate of the CAL-4 which is 1 Hz and the measurement group high rate blocks are provided at 20 Hz the product shall provide the closest in time to FBR value of slope correction.

Field 34) measurement spares - reserved for future use.



Advanced Computer Systems



*Instrument Processing Facility L1b*

Doc. No.: *CS-RS-ACS-GS-5106*  
Issue: *4.6*  
Date: *15/09/2009*  
Page: *70*

Field 35) Dry Tropospheric Correction – to be added to range measurement to correct for the propagation delay to the radar pulse, caused by the dry-gas component of the Earth’s atmosphere (see sec. 6.2.3.3.1 in [DPM]).

Field 36) Wet Tropospheric Correction - to be added to range measurement to correct for the propagation delay to the radar pulse, caused by the H<sub>2</sub>O component of the Earth’s atmosphere (see sec. 6.2.3.3.1 in [DPM]).

Field 37) Inverse Barometric Correction - to be added to range measurement to correct for the depression of the ocean surface caused by the local barometric pressure .

Field 38) Dynamic Atmospheric Correction - to be added to range measurement to correct for high frequency variability of the atmosphere (see sec. 6.2.3.3.2 in [DPM]).

Field 39) GIM Ionospheric Correction - to be added to range measurement to correct for the delay to the Radar pulse caused by free electrons in the ionosphere. Computed from GPS Ionospheric data (see sec. 6.2.3.3.3 in [DPM]).

Field 40) Model Ionospheric Correction - to be added to range measurement to correct for the delay to the Radar pulse caused by free electrons in the ionosphere. Computed from an Ionospheric model (see sec. 6.2.3.3.3 in [DPM]).

Field 41) Ocean Tide - to be added to the range to remove the effect of local tide and adjust the measurement to the mean sea surface (see sec. 6.2.3.3.4 in [DPM]).

Field 42) Long-Period equilibrium Ocean Tide - a component of total ocean tide. To be added to range to correct for the tidal effect (see sec. 6.2.3.3.4 in [DPM]).

Field 43) Ocean Loading Tide - to be added to the range to remove the effect of local tidal distortion to the Earth’s crust (see sec. 6.2.3.3.4 in [DPM]).

Field 44) Solid Earth Tide - to be added to the range to remove the effect of local tidal distortion in the Earth’s crust (see sec. 6.2.3.3.5 in [DPM]).

Field 45) Geocentric Polar Tide - to be added to the range to remove the effect of movement of the Earth’s rotational axis w.r.t. geographic location (see sec. 6.2.3.3.6 in [DPM]).

Field 46) Surface type flag - enumerated key to classify surface at nadir:

- 0 = Open Ocean
- 1 = Closed Sea
- 2 = Continental Ice
- 3 = Land

Field 47) Correction spares - reserved for future use.

Field 48) Correction status flag - used to show which correction algorithms have been called, see Table 2.3.3-5.

Field 49) Correction error flag - used to show if a correction algorithms returned an error when called, see Table 2.3.3-6.

Field 50) Correction spares - reserved for future use.

- Averaged Waveform Group for Low Rate Mode (PL mode) and SAR mode. (Once per L1b record)

Field 51) MDSR Time Stamp - corresponding to ground bounce time of the individual pulse, or middle of group of pulses for LRM.

Field 52) Latitude of measurement - corresponding to the MDSR Time Stamp.

Field 53) Longitude of measurement - (as for Latitude)

Field 54) Altitude - altitude of the Satellite CoM above reference ellipsoid - (as for Latitude)

Field 55) Window delay - The window delay from the telemetry converted to physical units. (2-way time)

Field 56) Averaged Power Echo - Array of 128 bins. Averaged from all individual L0 echoes in approx 1 second (20 for LRM, 5120 for SAR). Units are counts scaled to fit in the range 0-65535 and are converted to Watts by using the scaling parameters in the following 2 fields.

Field 57) Echo Scale factor 'A' (to scale echo to Watts)

Field 58) Echo Scale power 'B' (power of 2 to scale echo to Watts) the formula for converting the echo to Watts is: **Power in Watts = counts \* (A \* 10<sup>-9</sup>) \* 2<sup>B</sup>**

Field 59) Number of echoes averaged - normally 1820 for LRM (=91 averaged on-board \*20) or 5120 for SAR, but may be lower if some individual echoes are missing or rejected.

Field 60) Flags - for errors or information about echoes(LRM – Table 2.3.4-3a ; SAR - Table 2.3.4-3b).

ID	Definition	Bit (*)	Bit (**)	Setting
1.	1 Hz Echo Error	15	0	0 = Computed 1 = Not Computed
2.	Reserved	14-0	1-15	Set to zero

(\*) Ground Segment bit numbering standard [FMT-Guide]

(\*\*) Space Segment bit numbering standard

**Table 2.3.4-3a: Flags field in PL Average Waveform Group**

ID	Definition	Bit (*)	Bit (**)	Setting
1.	1 Hz Echo Error	15	0	0 = Computed 1 = Not Computed
2.	Reserved	14-1	1-14	Set to zero
3.	Mispointing error	0	15	1=bad angles 0=no error

(\*) Ground Segment bit numbering standard [FMT-Guide]

(\*\*) Space Segment bit numbering standard

**Table 2.3.4-4b: Flags field in SAR Average Waveform Group**

- Averaged Waveform Group for SARin mode (Once per L1b record)

This is the same as the above group but the waveform array is 512 bins instead of 128 and the number of echoes averaged is different.

Field 61) MDSR Time Stamp - corresponding to ground bounce time of the individual pulse, or middle of group of pulses for LRM.

Field 62) Latitude of measurement - corresponding to the MDSR Time Stamp.

Field 63) Longitude of measurement - (as for Latitude)

Field 64) Altitude - altitude of the Satellite CoM above reference ellipsoid - (as for Latitude)

Field 65) Window delay - The window delay from the telemetry converted to physical units. (2-way time)

Field 66) Averaged Power Echo - Array of 512 bins. Averaged from 1280 individual L0 echoes in SARin mode. Units are counts scaled to fit in the range 0-65535 and are converted to Watts by using the scaling parameters in the following 2 fields.

Field 67) Echo Scale factor 'A' (to scale echo to Watts)

Field 68) Echo Scale power 'B' (power of 2 to scale echo to Watts) the formula for converting the echo to Watts is: **Power in Watts = counts \* (A\*10<sup>-9</sup>) \* 2<sup>B</sup>**

Field 69) Number of echoes averaged - normally 1280 but may be lower if some individual echoes are missing or rejected.

Field 70. Flags - for errors or information about echoes (15 bit flag). See table 2.3.4-4

ID	Definition	PDS Bit	Setting
----	------------	---------	---------

1	Approximate beam steering	15	0 = no, 1 = approximate steering used
2	Exact beam steering	14	0 = no, 1 = exact steering used
3	Doppler weighting computed	13	0 = not computed, 1 = computed
4	Doppler weighting applied before stack	12	0 = not applied, 1 = applied
5	Multi look incomplete	11	0 = no (i.e. complete), 1 = incomplete
6	Beam angle steering error	10	0 = OK, 1 = error
7	Anti aliased power echoes	9	0 = no, 1 = anti aliased
8	Auto beam steering	8	0 = no, 1 = auto beam steering used <sup>2</sup>
9	reserved	7-0	set to 0

**Table 2.3.4-4: SARIN Waveform Flags**

- Waveform Group for LRM mode (20x per L1b record)

Field 71) Averaged Power Echo - Array of 128 bins. Averaged (on-board) from 91 individual echoes in Pulse limited mode (LRM). Units are counts scaled to fit in the range 0-65535 and are converted to Watts by using the scaling parameters in the following 2 fields.

Field 72) Echo Scale factor 'A' (to scale echo to Watts)

Field 73) Echo Scale power 'B' (power of 2 to scale echo to Watts) the formula for converting the echo to Watts is: **Power in Watts = counts \* (A \* 10<sup>-9</sup>) \* 2<sup>B</sup>**

Field 74) Number of echoes averaged - normally 91.

Field 75) Flags - for errors or information about echoes (15 bit flag). See table 2.3.4-4.

- Waveform Group for SAR mode (20x per L1b record)

Field 76) Averaged Power Echo - Array of 128 bins. Averaged from a set of Doppler beam echoes formed at a common surface location. Units are counts scaled to fit in the range 0-65535 and are converted to Watts by using the scaling parameters in the following 2 fields.

---

2 Beam steering method is chosen based on the on-board tracker height variation

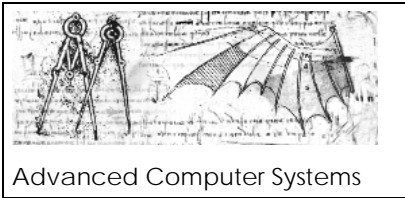

Field 77) Echo Scale factor 'A' (to scale echo to Watts)

Field 78) Echo Scale power 'B' (power of 2 to scale echo to Watts) the formula for converting the echo to Watts is: **Power in Watts = counts \* (A \* 10<sup>-9</sup>) \* 2<sup>B</sup>**

Field 79) Number of echoes averaged - variable typically 280.

Field 80) Flags - for errors or information about echoes (15 bit flag). See table 2.3.4-4.

Field 81) Beam Behaviour parameter - an array of 50 integers to characterise the shape of the set of Doppler echoes from a common surface location prior to stacking (averaging). Currently the first 7 numbers are defined as in table 2.3.4-5, while the remainder are reserved for future use.

Description:

- [0] Standard Deviation - Standard deviation of Gaussian fit to range integrated stack power.
- [1] Stack Centre - Mean of Gaussian fit to range integrated stack power.
- [2] Stack Scaled Amplitude - Normalised value 65535 This parameter is used in conjunction with level 1b linear and power of 2 multipliers to obtain the true fitted stack power maximum
- [3] Stack Skewness - 3rd moment providing the degree of asymmetry of the range integrated stack power distribution.
- [4] Stack Kurtosis - 4th moment. Measure of peakiness of range integrated stack power distribution
- [5] Standard deviation (as a function of angle, <microradians>) -
- [6] Stack Centre angle (as a function of angle, <microradians>) -

Index	Definition	Type	Setting
[0]	Standard Deviation	us	Unitless Stack beam/
[1]	Stack Centre (Beam in stack at maximum of the fitted gaussian)	us	Unitless Stack beam/100
[2]	Stack Scaled Amplitude	us	Normalised value 65535
[3]	Stack Skewness	ss	Unitless Value/100 or -99900 if cannot be computed
[4]	Stack Kurtosis	ss	Unitless Value/100 or -99900 if cannot be computed
[5]	Standard deviation (as a function of angle)	us	<microradians> Range 0 to 0.065525 radians (0 – 3.755°)
[6]	Stack Centre angle (as a function of angle)	ss	<microradians> Range -0.032767 to 0.032768 radians (-1.87741° – 1.87741°)
[7-49]	reserved		Set to zero

(\*) Ground Segment bit numbering standard [FMT-Guide]

(\*\*) Space Segment bit numbering standard

**Table 2.3.4-5: Flags Beam Behaviour Parameters**

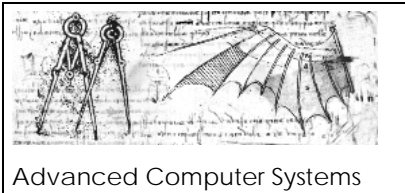

- Waveform Group for SARin mode (20x per L1b record)

Field 82) Averaged Power Echo - Array of 512 bins. Averaged from 2 sets of Doppler beam echoes formed (on 2 receive channels) at a common surface location. Units are counts scaled to fit in the range 0-65535 and are converted to Watts by using the scaling parameters in the following 2 fields.

Field 83) Echo Scale factor 'A' (to scale echo to Watts)

Field 84) Echo Scale power 'B' (power of 2 to scale echo to Watts) the formula for converting the echo to Watts is: **Power in Watts = counts \* (A \* 10<sup>-9</sup>) \* 2<sup>B</sup>**

Field 85) Number of echoes averaged - variable, typically 70.

Field 86) Flags - for errors or information about echoes (15 bit flag). See table 2.3.4-4

Field 87) Beam Behaviour parameter - an array of 50 integers to characterise the shape of the set of Doppler echoes from a common surface location prior to stacking (averaging). Currently the first 5 numbers are defined as in table 2.3.4-5.

Field 88) Coherence - Array of 512 bins. computed from the complex echoes on the 2 Rx channels

Field 89. Phase difference - Array of 512 bins. computed from the complex echoes on the 2 Rx channels. Values are in the range -p to +p radians, units are micro radians.

## 2.3.5 Monitoring MDS Record Structure

Monitoring Products are generated from LRM/TRK – SAR – SARIn and CAL4 (which are included in SARIN) Level 0 data.

All the types of MDS records defined hereafter are provided with the following basic structure:

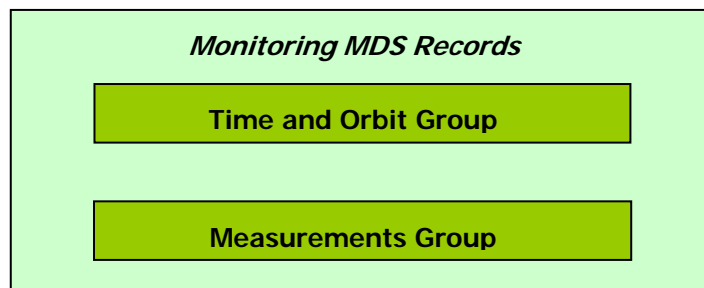

### 2.3.5.1 LRM/TRK Monitoring MDS Record Structure

For this type of product one type of MDS is defined. The MDS envelopes all the tracking information extracted from TM-LRM or TM-TRK telemetries and copied without conversions or corrections applied in the record structure . The decoded information are geolocated and time tagged.

Field	Description	Units	Bytes	Format
<b>Time and Orbit Group</b>				
1	Data Record Time (MDSR Time Stamp)	TAI	12	sl+2*ul
2	Record counter (always starting from 1)		4	ul
3	Latitude of measurement	10 <sup>-1</sup> μdeg	4	sl (see note 1)
4	Longitude of measurement	10 <sup>-1</sup> μdeg	4	sl (see note 1)
5	Altitude of COG above reference ellipsoid (interpolated value)	mm	4	sl
6	Instantaneous altitude rate derived from orbit	mm/sec	4	sl
7	Spare	-	10*1	uc
8	Monitoring Measurement Confidence Data (flag word)		4	ul (see table 2.3.5.1-2)

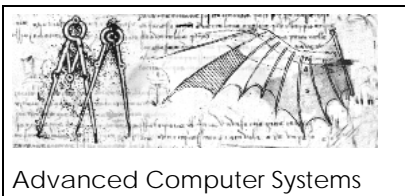

Advanced Computer Systems



Instrument Processing Facility L1b

Doc. No.: CS-RS-ACS-GS-5106  
 Issue: 4.6  
 Date: 15/09/2009  
 Page: 77

Measurements Group				
9	Source Sequence Count	-	2	us
10	Mode_ID (see Table 2.3.5.1-3)		1	uc
11	Chirp Bandwidth		1	uc
12	Rx Band Attenuation Flag		1	uc
13	Rx Channel Selected		1	uc
14	Loop Command		1	uc
15	Cycle Report		1	uc
16	AGC1	dB	1	uc
17	AGC2	dB	1	uc
18	Altitude command Ho	48.8 ps	4	sl (see note 2)
19	Vertical speed second order COR2	3.05 ps/rc	2	ss (see note 2)
20	Noise Measurement		2	us
21	Tracker Waveform (128 samples)	FFT Power Units	128*2	us
22	Number of TRK Echoes Accumulated		2	us
23	Spare		1	uc
24	CID TRK Packet		1	uc
25	SIRAL_Identifier (0 = Nominal 1 = Redundant)		1	uc
26	Spare		15*1	uc
<b>Total Record Size</b>			<b>340 bytes</b>	

**Table 2.3.5.1-1: LRM/TRK Monitoring Data Product MDS Records**

Notes:

- 1) this is an exotic unit exclusively used at binary record level to improve resolution of the lat and long fields
- 2) These are exotic units specific of SIRAL instrument

ID	Definition	Bit (*)	Bit (**)	Setting
1.	Block Degraded	31	0	0 = OK 1 = Degraded
2.	Blank Block	30	1	0 = OK 1 = Blank Block inserted for record padding
3.	Datation Degraded	29	2	0 = OK

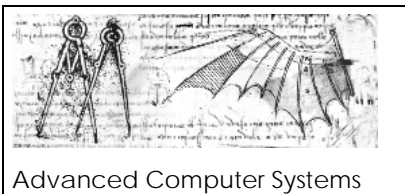

				1 = Datation is bad or not set
4.	Orbit Propagation Error	28	3	0 = OK 1 = Error (returned by CFI or independent check)
5.	Orbit File Change	27	4	0 = OK 1 = Orbit file has changed wrt previous record
6.	Orbit Discontinuity	26	5	0 = OK 1 = discontinuity (e.g. gap)
7.	Echo Saturation (from Cycle Report)	25	6	0 = OK 1 = Saturated
8.	Other Echo Error	24	7	0 = OK 1 = Echo Error (bit fields Tracking Echo Error or Echo Rx1 Error or Echo Rx2 Error set to 1)
9.	Rx 1 Channel Error for SARIN	23	8	0 = OK 1 = degraded or missing
10.	Rx 2 Channel error for SARIN	22	9	0 = OK 1 = degraded or missing
11.	Reserved	21-16	10-15	Set to zero
12.	TRK Echo Error	15	16	0 = OK 1 = empty (or null) tracking echo
13.	Echo Rx 1 Error	14	17	0 = OK 1 = empty (or null) raw echo
14.	Echo Rx2 Error	13	18	0 = OK 1 = empty (or null) raw echo
15.	Reserved	12-0	19-31	Set to zero

(\*) Ground Segment bit numbering standard [FMT-Guide]

(\*\*) Space Segment bit numbering standard

**Table 2.3.5.1-2: Monitoring Data Product MCD**

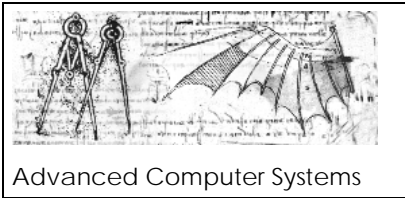

Advanced Computer Systems



*Instrument Processing Facility L1b*

Doc. No.: *CS-RS-ACS-GS-5106*  
Issue: *4.6*  
Date: *15/09/2009*  
Page: *79*

Field Name	Setting
Mode_ID	1 = LRM 2 = SAR 3 = SARIN

**Table 2.3.5.1-3: Monitoring Data Product Mode\_ID Field Definition**

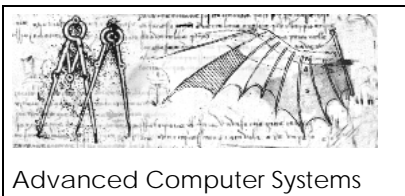

### 2.3.5.2 SAR Monitoring MDS Record Structure

For this type of product one type of MDS is defined. The MDS envelopes all the tracking information extracted from TM-TRK telemetries plus the waveform reconstructed from the 2D FFT processing of the raw echoes contained in the first packet of TM-ECHO-SAR type out of the four that the instrument produces within a tracking cycle. Conversions and instrument corrections are not applied. The decoded information are geolocated and time tagged.

Field	Description	Units	Bytes	Format
<b>Time and Orbit Group</b>				
1	Data Record Time (MDSR Time Stamp)	TAI	12	sl+2*ul
2	Record counter (always starting from 1)		4	ul
3	Latitude of measurement	10 <sup>-1</sup> μdeg	4	sl (see note 1)
4	Longitude of measurement	10 <sup>-1</sup> μdeg	4	sl (see note 1)
5	Altitude of COG above reference ellipsoid (interpolated value)	mm	4	sl
6	Instantaneous altitude rate derived from orbit	mm/sec	4	sl
7	Spare	-	10*1	uc
8	Monitoring Measurement Confidence Data (flag word)		4	ul (see table 2.3.5.1-2)
<b>Measurements Group</b>				
9	Source Sequence Count (from TM-ECHO-SAR)		2	us
10	Mode_ID (see Table 2.3.5.1-3)		1	uc
11	Chirp Bandwidth		1	uc
12	Rx Band Attenuation Flag		1	uc
13	Rx Channel Selected		1	uc
14	Loop Command		1	uc
15	Cycle Report		1	uc
16	AGC1	dB	1	uc
17	AGC2	dB	1	uc
18	Altitude command HO	48.8 ps	4	sl (see note 2)
19	Vertical speed second order HPR	3.05 ps/rc	2	ss (see note 2)
20	Noise Measurement		2	us
21	Tracker Waveform (128 samples)	FFT Power Units	128*2	us
22	Number of TRK Echoes Accumulated		2	us

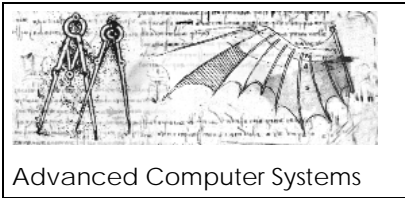

23	Decimation Factor		2	us
24	Normalised 2D Processed Echo SAR (power detected samples stored by doppler beam. 64 doppler beams in total. Each doppler beam contains 64 power detected samples)	FFT Units	Power 64 x 64 x 2	us
25	CID SAR Packet		1	uc
26	CID TRK Packet		1	uc
27	FFT2D Scale Factor	-	4	sl
28	FFT2D Scale Power	-	4	sl
29	SIRAL_Identifier (0 = Nominal 1 = Redundant)		1	uc
30	Spare		9*1	uc
<b>Total Record Size</b>			<b>8536 bytes</b>	

**Table 2.3.5.2-1: SAR Monitoring Data Product MDS Records**

Notes:

- 1) this is an exotic unit exclusively used at binary record level to improve resolution of the lat and long fields
- 2) These are exotic units specific of SIRAL instrument

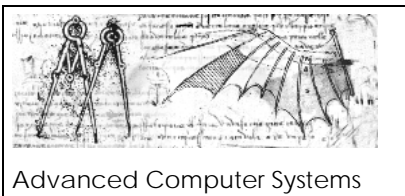

### 2.3.5.3 SARIN Monitoring MDS Record Structure

For this type of product one type of MDS is presently defined. The MDS envelopes all the tracking information extracted from TM-TRK telemetries plus the waveform reconstructed from a simple 2D FFT processing of the raw echoes contained in the first packet of TM-ECHO-SARIN type out of the four that the instrument produces within a tracking cycle. Conversions or instrument corrections are not applied. The decoded information are geolocated and time tagged.

Field	Description	Units	Bytes	Format
<b>Time and Orbit Group</b>				
1	Data Record Time (MDSR Time Stamp)	TAI	12	sl+2*ul
2	Record counter (always starting from 1)		4	ul
3	Latitude of measurement	10 <sup>-1</sup> μdeg	4	sl (see note 1)
4	Longitude of measurement	10 <sup>-1</sup> μdeg	4	sl (see note 1)
5	Altitude of COG above reference ellipsoid (interpolated value)	mm	4	sl
6	Instantaneous altitude rate derived from orbit	mm/sec	4	sl
7	Spare		10*1	uc
8	Monitoring Measurement Confidence Data (flag word)		4	ul (see table 2.3.5.1-2)
<b>Measurements Group</b>				
9	Source Sequence Count (From TM-ECHO-SARIN Master Ch)		2	us
10	Mode_ID (see Table 2.3.5.1-3)		1	uc
11	Chirp Bandwidth		1	uc
12	Rx Band Attenuation Flag		1	uc
13	Rx Channel Selected		1	uc
14	Loop Command		1	uc
15	Cycle Report		1	uc
16	AGC1	dB	1	uc
17	AGC2	dB	1	uc
18	Altitude command HO	48.8 ps	4	sl (see note 2)
19	Vertical speed second order HPR	3.05 ps/rc	2	ss (see note 2)
20	Noise Measurement		2	us
21	Tracker Waveform (128 samples)	FFT Power Units	128*2	us
22	Number of TRK Echoes Accumulated		2	us

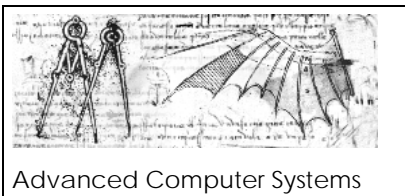

23	Decimation Factor		2	us
24	Normalised 2D Processed Echo SAR from Rx 1 Channel (power detected samples stored by doppler beam. 64 doppler beams in total. Each doppler beam contains 64 power detected samples)	FFT Power Units	64 x 64 x 2	us
25	Normalised 2D Processed Echo SAR from Rx 2 Channel (power detected samples stored by doppler beam. 64 doppler beams in total. Each doppler beam contains 64 power detected samples)	FFT Power Units	64 x 64 x 2	us
26	CID SARIN Packet Rx1 Channel		1	uc
27	CID SARIN Packet Rx 2 Channel		1	uc
28	SIRAL_Identifier (0 = Nominal 1 = Redundant)		1	uc
29	CID TRK Packet		1	uc
30	FFT2D Scale Factor for Rx1 Channel	-	4	sl
31	FFT2D Scale Power for Rx1 Channel	-	4	sl
32	FFT2D Scale Factor for Rx2 Channel	-	4	sl
33	FFT2D Scale Power for Rx2 Channel	-	4	sl
<b>Total Record Size</b>			<b>16728 bytes</b>	

**Table 2.3.5.3-1: SARIN Monitoring Data Product MDS Record**

Notes:

- 1) this is an exotic unit exclusively used at binary record level to improve resolution of the lat and long fields
- 2) These are exotic units specific of SIRAL instrument

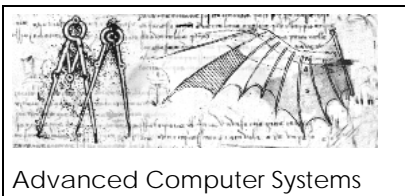

### 2.3.5.4 CAL4 Monitoring MDS Record Structure

An objective of the Monitoring applied to SARIn data is to provide information extracted from CAL4 packets. CAL 4 information are provided every 20 (TBC) tracking cycles. This product is then suited to exclusively collect the CAL 4 data found in the input Level 0 data stream. CAL4 data are maintained in their raw format, i.e. specific processing is not applied.

The decoded information are geolocated and time tagged.

Field	Description	Units	Bytes	Format
<b>Time and Orbit Group</b>				
1	Data Record Time (MDSR Time Stamp)	TAI	12	sl+2*ul
2	Record counter (always starting from 1)		4	ul
3	Latitude of measurement	10 <sup>-1</sup> μdeg	4	sl (see note 1)
4	Longitude of measurement	10 <sup>-1</sup> μdeg	4	sl (see note 1)
5	Altitude of COG above reference ellipsoid (interpolated value)	mm	4	ul
6	Instantaneous altitude rate derived from orbit	mm/sec	4	sl
7	Spare		10*1	uc
8	Monitoring Measurement Confidence Data (flag word)		4	ul (see table 2.3.5.1-2)
<b>Measurements Group</b>				
9	Source Sequence Count (from TM-ECHO-SARIN Master ch)		2	us
10	Mode_ID (see Table 2.3.5.1-3)		1	uc
11	Chirp Bandwidth		1	uc
12	Rx Band Attenuation Flag		1	uc
13	Rx Channel Selected		1	uc
14	Loop Command		1	uc
15	Cycle Report		1	uc
16	AGC1	dB	1	uc
17	AGC2	dB	1	uc
18	Altitude command HO	48.8 ps	4	sl (see note 2)
19	Vertical speed second order HPR	3.05 ps/rc	2	ss (see note 2)
20	Noise Measurement		2	us
21	CAL4 complex data from Rx 1 Channel [64, 512, 2]	-	64*512*2	sc

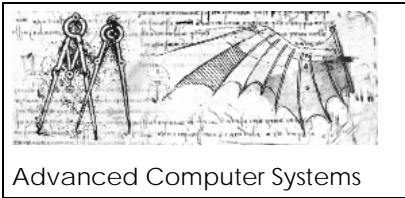

22	CAL4 complex data from Rx 2 Channel [64, 512, 2]	-	64*512*2	sc
23	CID SARIN Packet Rx1 Channel		1	uc
24	CID SARIN Packet Rx 2 Channel		1	uc
25	Spare		1	uc
26	CID TRK Packet		1	uc
27	SIRAL_Identifier (0 = Nominal 1 = Redundant)		1	uc
28	Spare		15*1	uc
<b>Total Record Size</b>			<b>131156 bytes</b>	

**Table 2.3.5.3-1: CAL4 Monitoring Data Product MDS Record**

Notes:

- 1) this is an exotic unit exclusively used at binary record level to improve resolution of the lat and long fields
- 2) These are exotic units specific of SIRAL instrument

### 2.3.6 Cal1 MDS Record Structures

Cal1 nominal Products are characterised by multiple record types (types 1 and 2) which are specific for the three possible calibration types in CAL1 Mode: LRM – SAR – SARIn.

All the types of MDS records defined hereafter are provided with the following basic structure:

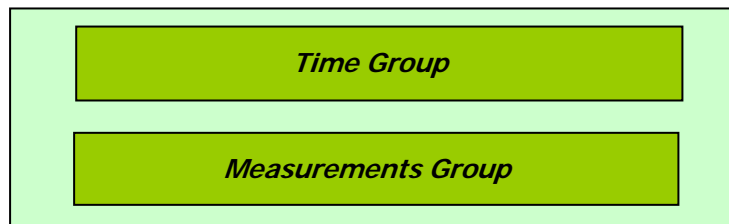

As minimum a product will be constituted by one MDS of the first type (described in the following sections) which contains the whole bunch of results of the calibration processing applied to an individual CAL1 level 0 file supplied in input and one MDS of the second type containing the calibration corrections (i.e. range and gain) and the associated MDSR time stamp.

Actually CAL 1 products may be generated starting from more than one Level 0 product. This possibility implies that in the product there will be as many MDS of the first type for as many CAL 1 Level 0 files supplied in input and a set of MDS of the second type containing interpolated calibration corrections with their associated time stamp.

There is actually a fourth type of calibration product which is generated from the special processing of the CAL1-SARIN exotic data (i.e. with AGC and Frequency Synthesiser Stepping Command). This product is still characterised by a single MDS.

#### 2.3.6.1 Cal1 LRM MDS Record Structures

The first type of MDS contains the reconstructed PTR measurements and the results of the processing applied to the reconstructed PTR.

Field	Description	Units	Bytes	Format
<b>Time Group</b>				
1	Data Record Time (MDSR Time Stamp)	TAI	12	sl+2*ul
2	USO Correction Factor	10-9	4	sl
3	Mode ID		2	us
4	Spare		2*1	uc
5	Instrument Configuration		4	ul

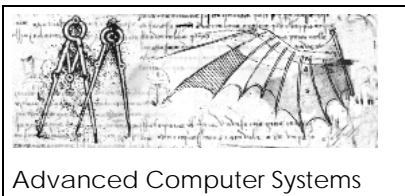

6	Record Counter (always starting from 1)		4	ul
7	Latitude of measurement	10 <sup>-1</sup> μdeg	4	sl (see note 1)
8	Longitude of measurement	10 <sup>-1</sup> μdeg	4	sl (see note 1)
9	Altitude of COG above reference ellipsoid (interpolated value)	mm	4	sl
10	Instantaneous altitude rate derived from orbit	mm/sec	4	sl
11	CAL1 Measurement Confidence Data (flag word)		4	ul see table 2.3.6.1-2
<b>Measurements Group</b>				
12	Normalised Point Target Response Samples (P*128) (P in range 1..64) (max 8192 samples)	-	8192*2	us
13	AGC (AGC_1 + AGC_2) Corrected	dB/100	4	sl (see note 3)
14	Tx-Rx Power*Gain Variation	dB/100	4	sl (see note 3)
15	Tx-Rx LO Differential Path delay (one way delay)	ps	4	sl
16	PSLR	dB/100	4	sl (see note 3)
17	3 dB Width	ps	4	sl
18	AGC_1 Command	dB/100	4	sl (see note 3)
19	AGC_2 Command	dB/100	4	sl (see note 3)
20	PTR Scale Factor	-	4	sl
21	PTR Scale Power	-	4	sl
22	Spare		4*1	uc
<b>Total Record Size</b>			16472 bytes	

**Table 2.3.6.1-1: Cal1 LRM MDS Records (Type 1)**

**Notes:**

- 1) this is an exotic unit exclusively used at binary record level to improve resolution of the lat and long fields
- 3) This is an exotic unit used for db-units related fields.

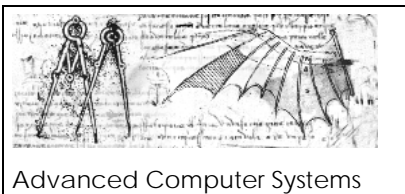

ID	Definition	Bit (*)	Bit (**)	Setting
1.	CAL Error	31	0	0 = Valid Record 1 = Invalid Record
2.	Reserved	30-28	1-3	Set to zero
3	Cal1 Correction Missing	27	4	0 = correction applied 1 = correction not applied
4	Complex Cal1 Correction from IPF DB	26	5	0 = correction from Complex CAL1 Product used 1 = correction from IPF DB used
5.	AGC Inconsistency	25	6	0 = OK (AGC is static) 1 = AGC Stepping detected
6.	Reserved	24	7	Set to zero
7.	PTR Computation Error	23	8	0 = Average PTR computed 1 = Error (not available)
8.	Cal2 Correction Missing	22	9	0 = correction applied to PTR 1 = correction not applied
9.	Cal 2 Correction from IPF DB	21	10	0 = correction from CAL1 Product used 1 = correction from IPF DB used
10.	DORIS USO Correction	20	11	0 = USO Correction Factor is available 1 = USO Correction Factor is not available
11.	PTR Analysis Method	19	12	0 = Gauss Fitting 1 = Search for Maximum
12.	PTR Width Error	18	13	0 = OK 1 = Error (width is out of range)
13.	PTR PSLR Error	17	14	0 = OK 1 = Error (PSLR is out of range)
14.	Gain Correction Error	16	15	0 = OK 1 = Error (value out of range)

15.	Delay Correction Error	15	16	0 = OK 1 = Error (value out of range)
16	Reserved	14	17-31	Set to zero

(\*) Ground Segment bit numbering standard [FMT-Guide]

(\*\*) Space Segment bit numbering standard

**Table 2.3.6.1-2: CAL1-LRM MCD**

The second type of MDS contains the interpolated corrections derived from the individual measurements:

Field	Description	Units	Bytes	Format
<b>Time Group</b>				
1	Data Record Time	TAI	12	sl+2*ul
2	Error Flag 0 = Valid Measurement 1 = Not Valid Measurement		4	ul
3	Record Counter (always starting from 1)		4	ul
4	Spares		4*1	uc
<b>Measurements Group</b>				
5	Tx-Rx Power*Gain Variation (interpolated value)	dB/100	4	sl (see note 3)
6	Tx-Rx LO Differential Path delay (interpolated value – one way delay)	ps	4	sl
7	Spare		12*1	uc
<b>Total Record Size</b>			<b>44 bytes</b>	

**Table 2.3.6.1-3: Cal1 LRM MDS Records (Type 2)**

Notes:

3) This is an exotic unit used for db-units related fields.

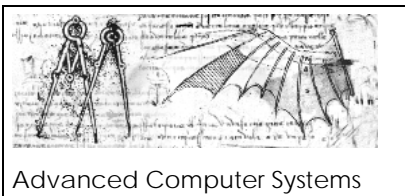

### 2.3.6.2 Cal1 SAR MDS Record Structures

The first type of MDS record contains the results of the elaborations required to provide the average RiRs (Range Impulse Response) and the average AiR (Azimuth Impulse Response), both zero padded by a factor of 64, as well as auxiliary information like the average phase correction, the range and gain corrections and quality parameters.

Field	Description	Units	Bytes	Format
<b>Time Group</b>				
1	Data Record Time (MDSR Time Stamp)	TAI	12	sl+2*ul
2	USO Correction Factor	10 <sup>-9</sup>	4	sl
3	Mode ID		2	us
4	Spare		2*1	uc
5	Instrument Configuration		4	ul
6	Record counter (always starting from 1)		4	ul
7	Latitude of measurement	10 <sup>-1</sup> μdeg	4	sl (see note 1)
8	Longitude of measurement	10 <sup>-1</sup> μdeg	4	sl (see note 1)
9	Altitude of COG above reference ellipsoid (interpolated value)	mm	4	sl
10	Instantaneous altitude rate derived from orbit	mm/sec	4	sl
11	CAL1 Measurement Confidence Data (flag word)		4	ul see table 2.3.6.1-2
<b>Measurements Group</b>				
12	Normalised Power Detected PTR (8192 samples: zero padded by factor of 64)	-	8192*2	us
13	AGC (AGC_1+AGC_2) Corrected	dB/100	4	sl (see note 3)
14	Tx-Rx Power*Gain Variation	dB/100	4	sl (see note 3)
15	Tx-Rx LO Differential Path delay (one way delay)	ps	4	sl
16	RiR PSLR	dB/100	4	sl (see note 3)
17	RiR 3 dB Width	ps	4	sl
18	Pulse to Pulse Phase Correction Curve (64 samples)	micro-radians	64*4	sl
19	Pulse to Pulse Amplitude Correction Curve (64 samples)	10 <sup>-6</sup>	64*4	sl
20	AGC_1 Command	dB/100	4	sl (see note 3)

21	AGC_2 Command	dB/100	4	sl (see note 3)
22	PTR Scale Factor	-	4	sl
23	PTR Scale Power	-	4	sl
24	Spares		12*1	uc
<b>Total Record Size</b>			<b>16992 bytes</b>	

**Table 2.3.6.2-1 : CAL1 SAR MDS Record (Type 1)**

Notes:

- 1) this is an exotic unit exclusively used at binary record level to improve resolution of the lat and long fields
- 3) This is an exotic unit used for db-units related fields.

ID	Definition	Bit (*)	Bit (**)	Setting
1.	CAL Error	31	0	0 = Valid Record 1 = Invalid Record
2.	Reserved	30-28	1-3	Set to zero
3	Cal1 Correction Missing	27	4	0 = correction applied 1 = correction not applied
4	AUTO Cal1 Correction from IPF DB	26	5	0 = correction from Complex CAL1 Product used 1 = correction from IPF DB used
5.	AGC Inconsistency	25	6	0 = OK (AGC is static) 1 = AGC Stepping detected
6.	Frequency Synthesiser Inconsistency	24	7	0 = OK (Freq. Synth Command is static) 1 = Freq. Synth. Comd. Stepping detected
7.	PTR Computation Error	23	8	0 = Average PTR computed 1 = Error (not available)
8.	Cal2 Correction Missing	22	9	0 = correction applied to PTR 1 = correction not applied
9.	Cal 2 Correction from IPF DB	21	10	0 = correction from CAL1 Product used 1 = correction from IPF DB used
10.	DORIS USO Correction	20	11	0 = USO Correction Factor is available 1 = USO Correction Factor is not available

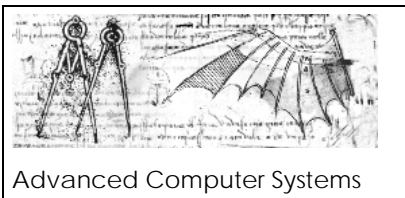

11.	PTR Analysis Method	19	12	0 = Gauss Fitting 1 = Search for Maximum
12.	PTR Width Error	18	13	0 = OK 1 = Error (width is out of range)
13.	PTR PSLR Error	17	14	0 = OK 1 = Error (PSLR is out of range)
14.	Gain Correction Error	16	15	0 = OK 1 = Error (value out of range)
15.	Delay Correction Error	15	16	0 = OK 1 = Error (value out of range)
16.	Burst Correction Error	14	17	0 = OK 1 = Error (not computed)
17.	Reserved	13-0	18-31	Set to zero

(\*) Ground Segment bit numbering standard [FMT-Guide]

(\*\*) Space Segment bit numbering standard

**Table 2.3.6.1-2: CAL1-SAR MCD**

The second type of MDS contains the interpolated corrections derived from the individual measurements:

Field	Description	Units	Bytes	Format
<b>Time Group</b>				
1	Data Record Time	TAI	12	sl+2*ul
2	Error Flag 0 = Valid Measurement 1 = Not Valid Measurement		4	ul
3	Record Counter (always starting from 1)		4	ul
4	Spares		4*1	uc
<b>Measurements Group</b>				
5	Tx-Rx Power*Gain Variation (interpolated value)	dB/100	4	sl (see note 3)
6	Tx-Rx LO Differential Path delay (interpolated value – one way delay)	ps	4	sl
7	Pulse to Pulse Phase Correction Curve (64 samples: interpolated values)	micro-radians	64*4	sl

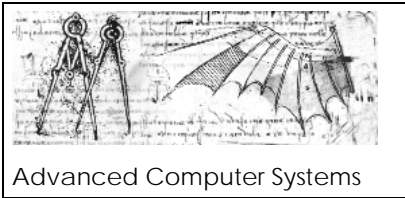

8	Pulse to Pulse Amplitude Correction Curve (64 samples: interpolated values)	$10^{-6}$	64*4	sl
9	Spare		12*1	uc
<b>Total Record Size</b>			<b>556 bytes</b>	

**Table 2.3.6.2-3 : CAL1 SAR MDS Record (Type 2)**

Notes:

3) This is an exotic unit used for dB-units related fields.

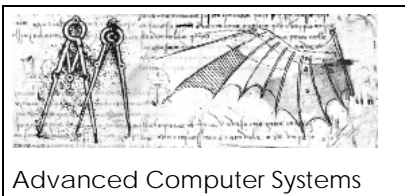

### 2.3.6.3 Cal1 SARIn MDS Record Structures

The first type of MDS record contains the results of the elaborations required to provide a set of 64 RiRs (Range Impulse Response) and the average AiR (Azimuth Impulse Response), both zero padded by a factor of 64, for each Rx channel as well as auxiliary information like the average phase correction, the range and gain corrections and quality parameters.

Field	Description	Units	Bytes	Format
<b>Time Group</b>				
1	Data Record Time (MDSR Time Stamp)	TAI	12	sl+2*ul
2	USO Correction Factor		4	sl
3	Mode ID		2	us
4	Spare		2*1	uc
5	Instrument Configuration		4	ul
6	Record counter (always starting from 1)		4	ul
7	Latitude of measurement	10 <sup>-1</sup> μdeg	4	sl (see note 1)
8	Longitude of measurement	10 <sup>-1</sup> μdeg	4	sl (see note 1)
9	Altitude of COG above reference ellipsoid (interpolated value)	mm	4	sl
10	Instantaneous altitude rate derived from orbit	mm/sec	4	sl
11	CAL1 Measurement Confidence Data (flag word)		4	ul see table 2.3.6.3-2
<b>Measurements Group</b>				
<b>Rx 1 Channel: Retrieved Parameters</b>				
12	Normalised Power Detected PTR of Rx1 Channel (8192 samples: zero padded by factor of 16)	-	8192*2	us (see note 3)
13	AGC (AGC_1 + AGC_2) Corrected of Rx1 Channel	dB/100	4	sl (see note 2)
14	Tx-Rx Power*Gain Variation of Rx1 Channel	dB/100	4	sl (see note 2)
15	Tx-Rx LO Differential Path delay of Rx1 Channel (one way delay)	ps	4	sl
16	PTR PSLR	dB/100	4	sl (see note 2)
17	PTR 3 dB Width	ps	4	sl
18	Pulse to Pulse Phase Correction Curve (64 samples) of Rx 1 Channel	Micro-radians	64*4	sl
19	Pulse to Pulse Amplitude Correction Curve (64 samples) of Rx 1 Channel	10 <sup>-6</sup>	64*4	sl
20	Rx1 PTR Scale Factor	-	4	sl

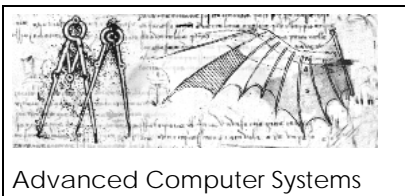

21	Rx1 PTR Scale Power	-	4	sl
22	Spare		12*1	uc
<b>Rx 2 Channel: Retrieved Parameters</b>				
23	Normalised Power Detected PTR of Rx2 channel (8192 samples: zero padded by factor of 16)	-	8192*2	us (see note 3)
24	AGC (AGC_1 + AGC_2) Corrected of Rx2 Channel	dB/100	4	sl (see note 2)
25	Tx-Rx Power*Gain Variation of Rx2 Channel	dB/100	4	sl (see note 2)
26	Tx-Rx LO Differential Path delay of Rx2 Channel (one way delay)	ps	4	sl
27	RiR PSLR	dB/100	4	sl (see note 2)
28	RiR 3 dB Width	ps	4	sl
29	Pulse to Pulse Phase Correction Curve (64 samples) of Rx 2 Channel	Micro-radians	64*4	sl
30	Pulse to Pulse Amplitude Correction Curve (64 samples) of Rx 2 Channel	10 <sup>-6</sup>	64*4	sl
31	Rx2 PTR Scale Factor	-	4	sl
32	Rx2 PTR Scale Power	-	4	sl
33	Spare		12*1	uc
<b>Phase and Amplitude of Rx1 and Rx2 (extracted from RiR peaks)</b>				
34	Phase PTR Peak Rx 1	Micro-radians	4	sl
35	Amplitude PTR Peak Rx 1	10 <sup>-6</sup>	4	sl
36	Phase RiR Peak Rx 2	Micro-radians	4	sl
37	Amplitude RiR Peak Rx 2	10 <sup>-6</sup>	4	sl
<b>Common Rx1 and Rx2 Instrument Commands</b>				
38	AGC_1 Command	dB/100	4	sl
39	AGC_2 Command	dB/100	4	sl
40	Frequency Synthesiser Command	-	2	us
41	Spares		10*1	uc
<b>Total Record Size</b>			<b>33956 bytes</b>	

Table 2.3.6.3-1 : CAL1 SARIn MDS Record (Type 1)

Notes:

- 1) this is an exotic unit exclusively used at binary record level to improve resolution of the lat and long fields
- 2) This is an exotic unit used for dB-units related fields.
- 3) The PTR computed by CAL1SARin processor is 32768 samples long. The central portion [12289,20480] is stored in l1b product.

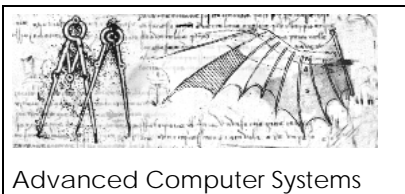

ID	Definition	Bit (*)	Bit (**)	Setting
1.	CAL Error	31	0	0 = Valid Record 1 = Invalid Record (logical AND between CAL_Rx1_error and CAL_Rx2_error)
2.	CAL Rx 1 Error	30	1	0 = Rx1 related corrections valid 1 = Rx1 related corrections not valid
3.	CAL Rx 1 Error	29	2	0 = Rx1 related corrections valid 1 = Rx1 related corrections not valid
4.	Reserved	28	3	Set to zero
5	Cal1 Correction Missing	27	4	0 = correction applied 1 = correction not applied
6	Complex Cal1 Correction from IPF DB	26	5	0 = correction from Complex CAL1 Product used 1 = correction from IPF DB used
7.	AGC Inconsistency	25	6	0 = OK (AGC is static) 1 = AGC Stepping detected
8.	Frequency Synthesiser Inconsistency	24	7	0 = OK (Freq. Synth Command is static) 1 = Freq. Synth. Comd. Stepping detected
9.	PTR Computation Rx1 Error	23	8	0 = Average PTR from Rx1 computed 1 = Error (not available)
10.	PTR Computation Rx2 Error	22	9	0 = Average PTR from Rx2 computed 1 = Error (not available)
11.	Cal2 Correction Missing	21	10	0 = correction applied to PTR 1 = correction not applied
12.	Cal 2 Rx 1 Correction from IPF DB	20	11	0 = correction from CAL1 Rx1 Product used 1 = correction from IPF DB used
13.	Cal 2 Rx 2 Correction from IPF DB	19	12	0 = correction from CAL1 Rx2 Product used 1 = correction from IPF DB used
14.	DORIS USO Correction	18	13	0 = USO Correction Factor is available 1 = USO Correction Factor is not

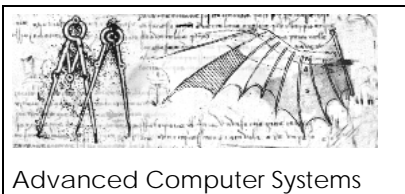

				available
15.	PTR Analysis Method	17	14	0 = Gauss Fitting 1 = Search for Maximum
16.	PTR Width Rx1 Error	16	15	0 = OK 1 = Error (width is out of range)
17.	PTR Width Rx2 Error	15	16	0 = OK 1 = Error (width is out of range)
18.	PTR PSLR Rx1 Error	14	17	0 = OK 1 = Error (PSLR is out of range)
19.	PTR PSLR Rx2 Error	13	18	0 = OK 1 = Error (PSLR is out of range)
20.	Gain Correction Rx1 Error	12	19	0 = OK 1 = Error (value out of range)
21.	Delay Correction Rx1 Error	11	20	0 = OK 1 = Error (value out of range)
22.	Gain Correction Rx2 Error	10	21	0 = OK 1 = Error (value out of range)
23.	Delay Correction Rx2 Error	9	22	0 = OK 1 = Error (value out of range)
24.	Burst Rx1 Correction Error	8	23	0 = OK 1 = Error (not computed)
25.	Burst Rx2 Correction Error	7	24	0 = OK 1 = Error (not computed)
26.	Reserved	6-0	25-31	Set to zero

(\*) Ground Segment bit numbering standard [FMT-Guide]

(\*\*) Space Segment bit numbering standard

**Table 2.3.6.3-2: CAL1-SARIN MCD**

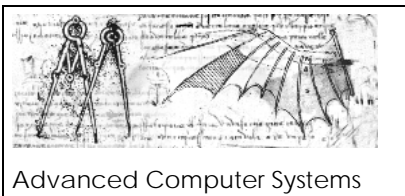

The second type of MDS contains the interpolated corrections derived from the individual measurements:

Field	Description	Units	Bytes	Format
<b>Time Group</b>				
1	Data Record Time	TAI	12	sl+2*ul
2	Error Flag 0 = Valid Measurement 1 = Not Valid Measurement		4	ul
3	Record Counter (always starting from 1)		4	ul
4	Spares		4*1	uc
<b>Measurements Group</b>				
5	Tx-Rx Power*Gain Variation (interpolated value) of Rx 1 Channel	dB/100	4	sl (see note 3)
6	Tx-Rx LO Differential Path delay (interpolated value – one way delay) of Rx 1 Channel	ps	4	sl
7	Pulse to Pulse Phase Correction Curve (64 samples: interpolated values) of Rx 1 Channel	Micro-radians	64*4	sl
8	Pulse to Pulse Amplitude Correction Curve (64 samples: interpolated values) of Rx 1 Channel	10 <sup>-6</sup>	64*4	sl
9	Tx-Rx Power*Gain Variation (interpolated value) of Rx 2 Channel	dB/100	4	sl (see note 3)
10	Tx-Rx LO Differential Path delay (interpolated value – one way delay) of Rx 2 Channel	ps	4	sl
11	Pulse to Pulse Phase Correction Curve (64 samples: interpolated values) of Rx 2 Channel	Micro-radians	64*4	sl
12	Pulse to Pulse Amplitude Correction Curve (64 samples: interpolated values) of Rx 2 Channel	10 <sup>-6</sup>	64*4	sl
13	Phase RiR Peak Rx 1 (interpolated value)	Micro-radians	4	sl
14	Amplitude RiR Peak Rx 1 (interpolated value)	10 <sup>-6</sup>	4	sl
15	Phase RiR Peak Rx 2 (interpolated value)	Micro-radians	4	sl
16	Amplitude RiR Peak Rx 2 (interpolated value)	10 <sup>-6</sup>	4	sl
17	Spare		12*1	uc
Total Record Size			1092 bytes	

**Table 2.3.6.3-3 : CAL1 SARIn MDS Record (Type 2)**



Advanced Computer Systems



*Instrument Processing Facility L1b*

Doc. No.: *CS-RS-ACS-GS-5106*  
Issue: *4.6*  
Date: *15/09/2009*  
Page: *99*

Notes:

3) This is an exotic unit used for db-units related fields.

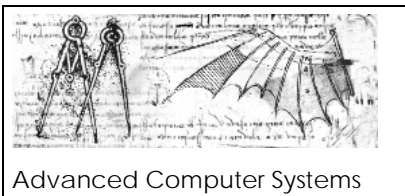

### 2.3.6.4 AUTO CAL1-SARIN MDS Record

Field	Description	Units	Size (Bytes)	Format
<b>Time Group</b>				
1	Data record time	TAI	12	sl+2*ul
2	USO correction factor	10 <sup>-9</sup>	4	sl
3	Mode ID	N/A	2	us
4	spare		2	us
5	Instrument config	N/A	4	ul
6	Record count		4	sl
7	latitude	10 <sup>-7</sup> Deg	4	sl (see note 1)
8	longitude	10 <sup>-7</sup> Deg	4	sl (see note 1)
<b>Measurement Group</b>				
9	Calibrated AGC1 chain 1 (32 combinations)	dB/100	128	sl (see note 3)
10	Calibrated AGC1 chain 2 (32 combinations)	dB/100	128	sl (see note 3)
11	Calibrated AGC2 chain 1 (32 combinations)	dB/100	128	sl (see note 3)
12	Calibrated AGC2 chain 2 (32 combinations)	dB/100	128	sl (see note 3)
13	Average Gain Calibration Component	dB/100	4	sl
14	Calibrated AGC command table (63 Commands) chain 1	dB/100	252	sl (see note 3)
15	Calibrated AGC measurement command table chain 2	dB/100	252	sl (see note 3)
16	Inversion quality chain 1 (AGC cal)	TBD	4	sl
17	Inversion quality chain 2 (AGC cal)	TBD	4	sl
18	Phase difference curves 32*11 AGC 1 settings	10 <sup>-6</sup> Rad	1408	sl
19	Phase difference curves 32*11 AGC 2 settings	10 <sup>-6</sup> Rad	1408	sl
20	11 Frequency averaged components used to reconstruct AGC phase tables	10 <sup>-6</sup> Rad	44	sl
21	Frequency interpolated (512 points) phase difference correction curves 63*512 for all AGC measurement command table settings	10 <sup>-6</sup> Rad	129024	sl
22	Phase difference curve at AGC setting CAL4_AGC1, CAL4_AGC2 with attenuator OFF		44	sl
23	Phase difference curve at AGC setting CAL4_AGC1, CAL4_AGC2 with attenuator ON		44	sl
24	Measurements of attenuator calibration curve (11 frequencies)	10 <sup>-6</sup> Rad	44	sl

25	Attenuator calibration correction curve interpolated over 512 range samples	10 <sup>-6</sup> Rad	2048	sl
26	Measurements of calibration curves at 8 ADC power level (-30dBm to -16dBm) in steps pf 2dB, at 11 frequencies	10 <sup>-6</sup> Rad	352	sl
27	8 ADC power level (-30dBm to -16dBm) calibration correction curves in steps pf 2dB interpolated over 512 range bins	10 <sup>-6</sup> Rad	16384	sl
28	Inversion quality at 11 frequencies (Phase difference cal)	TBD	44	sl
29	MCD (see table 2.3.6.4-2)	-	4	ul
		TOTAL	151912	

**Table 2.3.6.4-1 : CAL1 SARIn Exotic MDS Record**

- 1) this is an exotic unit exclusively used at binary record level to improve resolution of the lat and long fields
- 3) This is an exotic unit used for dB-units related fields.

ID	Definition	Bit(*)	Bit(**)	Setting
1.	CAL Error	31	0	0 = Valid Record 1 = Invalid Record
2.	Reserved	30-13	1-18	Set to zero
3.-4.	AGC results from SICCFR or SIC1B or IPFDB	12-11	19-20	0 = SICCFR, 1 = SIC1B, 2 = IPFDB
5.-6.	ADC results from SICCFR or SIC1B or IPFDB	10-9	21-22	0 = SICCFR, 1 = SIC1B, 2 = IPFDB
7.	AGC calibration computed	8	23	0 = computed, 1 = not computed
8.	ADC calibration computed	7	24	0 = computed, 1 = not computed
9	Auto CAL-1 Attenuator calibrated	6	25	0= computed 1=not computed
10	Gain inversion matrix condition greater than threshold	5	26	0 = OK 1=threshold exceeded
11	Phase difference matrix condition greater then threshold	4	27	0 = OK 1=threshold exceeded
12	reserved	3-0	28-31	Set to zero

**Table 2.3.6.3-2: CAL1-SARIN Exotic MCD**

### 2.3.7 Cal2 MDS Record Structure

Cal2 Products are characterised by multiple record types which are specific for the two possible calibration types in CAL2 Mode: SAR – SARIn.

The MDS structures are based on the [MSL-PS] documents with amendments and corrections as identified at present.

#### 2.3.7.1 Cal2 SAR MDS Record Structure

Field	Description	Units	Bytes	Format
<b>Time Group</b>				
1	Data Record Time (MDSR Time Stamp)	TAI	12	sl+2*ul
2	USO Correction Factor		4	sl
3	Mode ID		2	us
4	Spare		2*1	uc
5	Instrument Configuration		4	ul
6	Record counter (fixed to 1)		4	ul
7	Latitude of measurement	10 <sup>-1</sup> μdeg	4	sl (see note 1)
8	Longitude of measurement	10 <sup>-1</sup> μdeg	4	sl (see note 1)
9	Altitude of COG above reference ellipsoid (interpolated value)	mm	4	sl
10	Instantaneous altitude rate derived from orbit	mm/sec	4	sl
11	CAL2 Measurement Confidence Data (flag word)		4	ul (see table 2.3.7.1-2)
<b>Measurements Group</b>				
12	LPF Filter Shape Correction Mask(128 power samples)	10 <sup>-6</sup>	128*4	sl
13	Number of Noise Spectra averaged		4	ul
14	AGC (AGC_1 + AGC_2) Corrected	dB/100	4	sl (see note 2)
15	AGC_1 Command	dB/100	4	sl (see note 2)
16	AGC_2 Command	dB/100	4	sl (see note 2)
17	Number of Spikes from AUX_SIRDBF	-	2	us
18	Number of Spikes autodetected	-	2	us
19	Spare		16*1	uc
<b>Total Size</b>			<b>596 bytes</b>	

**Table 2.3.7.1-1: Cal 2 SAR MDS Record Structure**

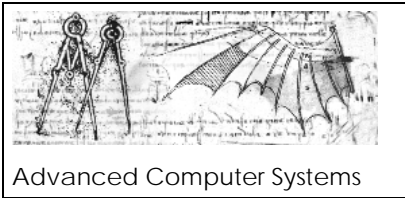

Notes:

- 1) this is an exotic unit exclusively used at binary record level to improve resolution of the lat and long fields
- 2) This is an exotic unit used for db-units related fields.

ID	Definition	Bit (*)	Bit (**)	Setting
1.	CAL Error	31	0	0 = Valid Record 1 = Invalid Record
2.	Reserved	30-28	1-3	Set to zero
3	Cal1 Correction Missing	27	4	0 = correction applied 1 = correction not applied
4	Complex Cal1 Correction from IPF DB	26	5	0 = correction from Complex CAL1 Product used 1 = correction from IPF DB used
5.	AGC Inconsistency	25	6	0 = OK (AGC is static) 1 = AGC Stepping detected
6.	Noise Spectra Computation Error	24	7	0 = OK 1 = Error (some spectra were not computed)
7.	Noise Power Error	23	8	0 = OK 1 = Mean Noise Power out of Range
8.	Reserved	22-0	9-31	Set to zero

(\*) Ground Segment bit numbering standard [FMT-Guide]

(\*\*) Space Segment bit numbering standard

**Table 2.3.7.1-2: CAL2 MCD**

### 2.3.7.2 Cal 2 SARIn MDS Record Structure

Field	Description	Units	Bytes	Format
<b>Time Group</b>				
1	Data Record Time (MDSR Time Stamp)	TAI	12	sl+2*ul
2	USO Correction Factor		4	sl
3	Mode ID		2	us
4	Spare		2*1	uc
5	Instrument Configuration		4	ul
6	Record counter (fixed to 1)		4	ul
7	Latitude of measurement	10 <sup>-1</sup> μdeg	4	sl (see note 1)
8	Longitude of measurement	10 <sup>-1</sup> μdeg	4	sl (see note 1)
9	Altitude of COG above reference ellipsoid (interpolated value)	mm	4	sl
10	Instantaneous altitude rate derived from orbit	mm/sec	4	sl
11	CAL2 Measurement Confidence Data (flag word)		4	ul (see Table 2.3.7.1-2)
<b>Measurements Group</b>				
12	LPF Filter Shape Correction Mask(512 power samples)	10 <sup>-6</sup>	512*4	sl
13	Number of Noise Spectra averaged		4	ul
14	AGC (AGC_1 + AGC_2) Corrected	dB/100	4	sl (see note 3)
15	AGC_1 Command	dB/100	4	sl (see note 3)
16	AGC_2 Command	dB/100	4	sl (see note 3)
17	Number of Spikes from AUX_SIRDBF	-	2	us
18	Number of Spikes autodetected	-	2	us
17	Spare		16*1	uc
<b>Total Size</b>			<b>2132 bytes</b>	

**Table 2.3.7.2-1: Cal 2 SARIn MDS Record Structure**

**Notes:**

- 1) this is an exotic unit exclusively used at binary record level to improve resolution of the lat and long fields
- 3) This is an exotic unit used for db-units related fields.

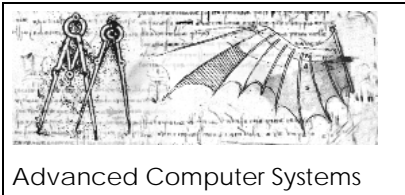

### 3 CRYOSAT LEVEL-1 PRODUCTS

The following table provides the Product ID for each product generated by the IPF1.

Product ID	Description
<b>SIR1SAR_FR</b>	Level 1 FBR SAR Mode (Rx1 Channel)
<b>SIR2SAR_FR</b>	Level 1 FBR SAR Mode (Rx2 Channel)
<b>SIR_SIN_FR</b>	Level 1 FBR SARin Mode
<b>SIR_LRM_1B</b>	Level-1 Product Low Rate Mode
<b>SIR_FDM_1B</b>	Level-1 Product Fast Delivery Ocean
<b>SIR_SAR_1B</b>	Level-1 SAR Mode
<b>SIR_SIN_1B</b>	Level-1 SARin Mode
<b>SIR1LRC11B</b>	Level-1 CAL1 Low Rate Mode (Rx1 Channel)
<b>SIR2LRC11B</b>	Level-1 CAL1 Low Rate Mode (Rx2 Channel)
<b>SIR1SAC11B</b>	Level-1 CAL1 SAR Mode (Rx1 Channel)
<b>SIR2SAC11B</b>	Level-1 CAL1 SAR Mode (Rx2 Channel)
<b>SIR_SIC11B</b>	Level-1 CAL1 SARin Mode
<b>SIR_SICC1B</b>	Level-1 CAL1 SARIN Exotic Data
<b>SIR1SAC21B</b>	Level-1 CAL2 SAR Mode (Rx1 Channel)
<b>SIR2SAC21B</b>	Level-1 CAL2 SAR Mode (Rx2 Channel)
<b>SIR1SIC21B</b>	Level-1 CAL2 SARin Mode (Rx1 Channel)
<b>SIR2SIC21B</b>	Level-1 CAL2 SARin Mode (Rx1 Channel)
<b>SIR1LRM_OM</b>	LRM and TRK Monitoring Data from Rx 1 Channel
<b>SIR2LRM_OM</b>	LRM and TRK Monitoring Data from Rx 2 Channel
<b>SIR1SAR_OM</b>	SAR Monitoring Data from Rx 1 Channel
<b>SIR2SAR_OM</b>	SAR Monitoring Data from Rx 1 Channel
<b>SIR_SIN_OM</b>	SARIN Monitoring Data
<b>SIR_SIC40M</b>	CAL4 Monitoring Data

**Table 3-1: Level-1 products list**

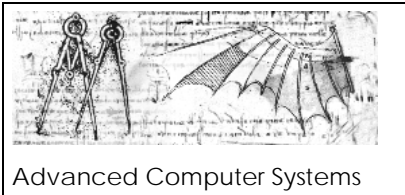

Advanced Computer Systems



Instrument Processing Facility L1b

Doc. No.: CS-RS-ACS-GS-5106  
Issue: 4.6  
Date: 15/09/2009  
Page: 106

### 3.1 FILE NAMES

The file name of each Level-1 product will follow what specified in [MASTER-ICD], i.e:

*MM\_CCCC\_TTTTTTTTTT\_yyyymmddThhmmss\_YYYYMMDDTHHMMSS\_bvvv.HDR*  
*MM\_CCCC\_TTTTTTTTTT\_yyyymmddThhmmss\_YYYYMMDDTHHMMSS\_bvvv.DBL*

where

*MM* is the mission identifier **CS** for Cryosat

*CCCC* is the file class (i.e.: OPER for routine operation, NRT\_ for Near Real Time, RPRO for Reprocessing, TEST for Testing or Tixx for stand alone IPF1 testing associated to Test Data Sets tagged as Tixx, LTA\_ for products generated in the Long Term Archive ).

*TTTTTTTTTT* is the file type and corresponds to the Product ID of the Table 3-1

*yyymmddThhmmss* is the validity start time and correspond to the time of the first valid record stored in the Interim FBR.

*YYYYMMDDTHHMMSS* is the validity stop time and correspond to time of the last valid record stored in the Interim FBR.

*b* is the baseline identifier as read-in from the PCONF

*vvv* is the version number

For example in case of an operational Level-1 product of the SIRAL instrument in Low Rate Mode in baseline number A and version 1 the name could be:

*CS\_OPER\_SIR\_LRM1B\_20030624T075728\_20030624T080231\_A001.HDR*  
*CS\_OPER\_SIR\_LRM1B\_20030624T075728\_20030624T080231\_A001.DBL*

The file with extension *.HDR* is the xml Header and the file with the extension *.DBL* is the Level 0 Product file following the format of the correspondent ENVISAT one.

END OF DOCUMENT