

# Sentinel-1 System Overview

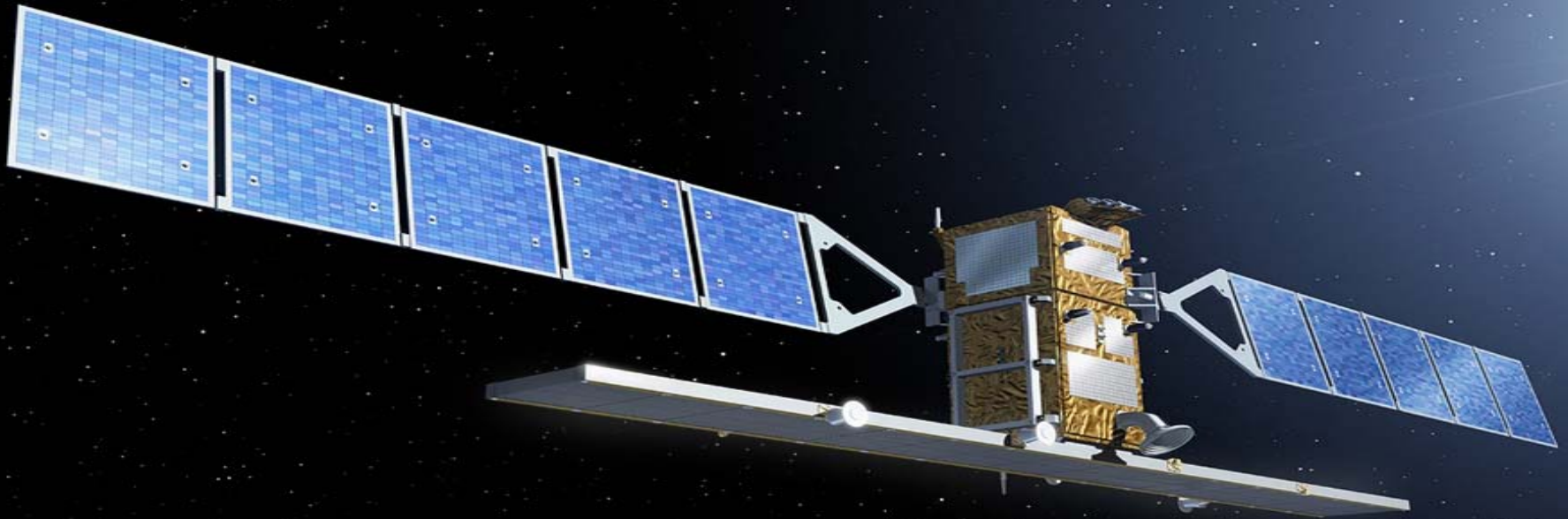

Dirk Geudtner, Ramón Torres, Paul Snoeij, Malcolm Davidson

European Space Agency, ESTEC



# Global Monitoring for Environment and Security (GMES)



- EU-led program aiming at providing operational user services based on Earth observation and in-situ data
- Provides relevant information to policy-makers, institutional EU + MS authorities (Core service), and local/regional users (Downstream)

## Space Component – developed & coordinated by ESA

- ✓ Sentinels (1-5)
- ✓ Contributing (national) Missions – Data Access



## In-situ component – coordinated by EEA

- ✓ Observations mostly within national responsibility, with coordination at European level
- ✓ Air, sea- and ground-based systems and instrumentations



## Service component – coordinated by EC

- ✓ Mapping and forecasting services: [Land](#), [Marine](#), [Atmosphere](#), [Emergency](#), [Security](#) and [Climate Change](#)

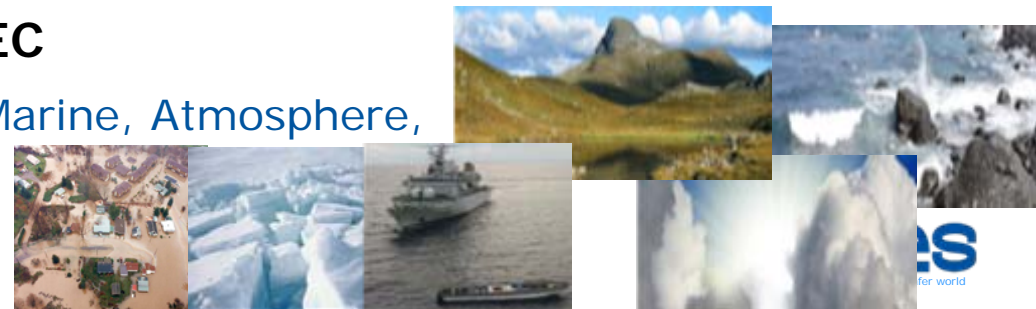

# Sentinel-1 Mission Facts



- Constellation of two satellites (A & B units)
- C-Band Synthetic Aperture Radar Payload
- Near-Polar sun-synchronous (dawn-dusk) orbit at 693 km altitude
- Both S-1 satellites are in the same orbit (180 deg. phased in orbit)
- 12 days repeat cycle (1 satellite), 6 days for the constellation
- 7 years design life time with consumables for 12 years
- Launch of Sentinel-1 A scheduled for May 2013 followed by Sentinel-1 B 18 months later

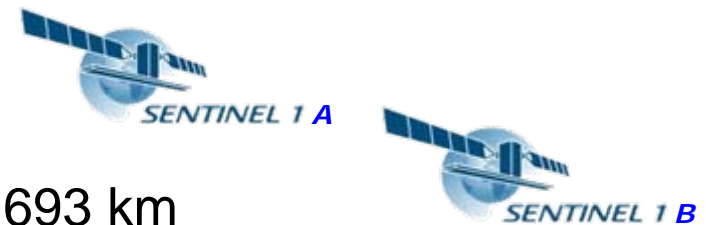

# Sentinel-1 Mission Objectives and Requirements

(1/2)



- Provide routinely and systematically SAR data to *GMES Services* and *National services* focussing on the following applications
  - ✓ Monitoring of Marine Environment (e.g. oil spills, sea ice zones)
  - ✓ Surveillance of Maritime Transport zones (e.g. European and North Atlantic zones)
  - ✓ Land Monitoring (e.g. land cover, surface deformation risk)
  - ✓ Mapping in support of crisis situations (e.g. natural disasters and humanitarian aid)
  - ✓ Monitoring of Polar environment (e.g. ice shelves and glaciers)

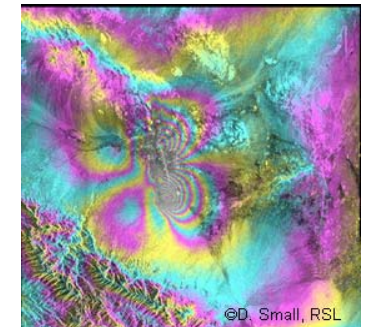
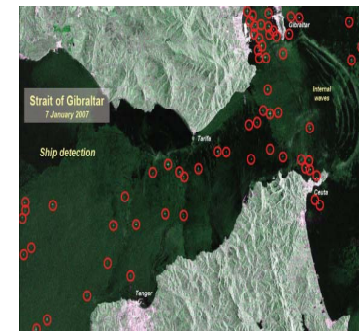
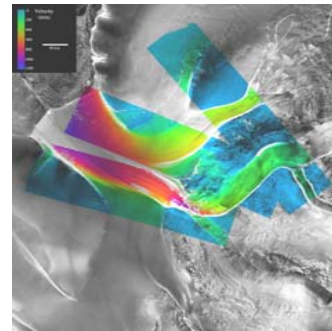
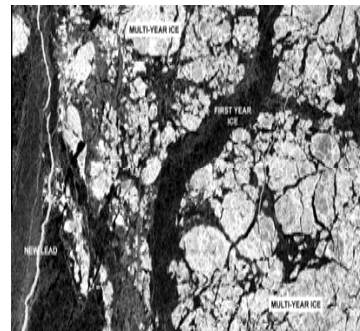
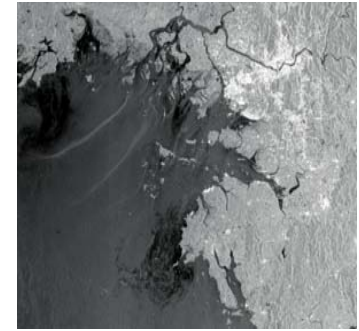

# Sentinel-1 Mission Objectives and Requirements

(2/2)



- Provide C-band SAR data continuity at medium resolution
- Complete global coverage within a single repeat orbit cycle (175 orbits in 12 days) and systematic revisit (greatly improved as compared to ENVISAT)
- Data quality similar or better than ERS/ENVISAT (e.g. equalized performance across the swath)
- Systematic data acquisition to enable build-up of long observation time series
- High system availability (SAR duty cycle)
- Conflict-free operations w.r.t. SAR mode selection for data acquisition (swath width and polarization)
- Capability for repeat-pass SAR interferometry, especially TOPS InSAR
- On-board data latency (i.e. downlink) requires
  - ✓ max 200 min (2 orbits)
  - ✓ One orbit for support of near real time (3h) applications
  - ✓ Simultaneous SAR acquisition and downlink for real time applications

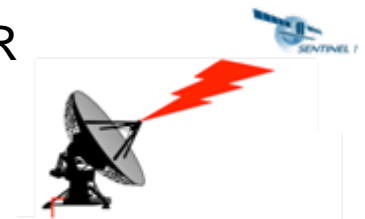
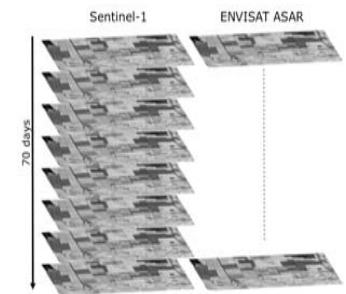
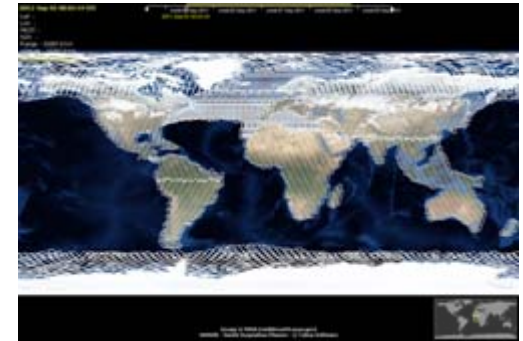

# Sentinel-1 Reference Scenario for System Analysis - Coverage

**Average Revisit Time S-1A Satellite**

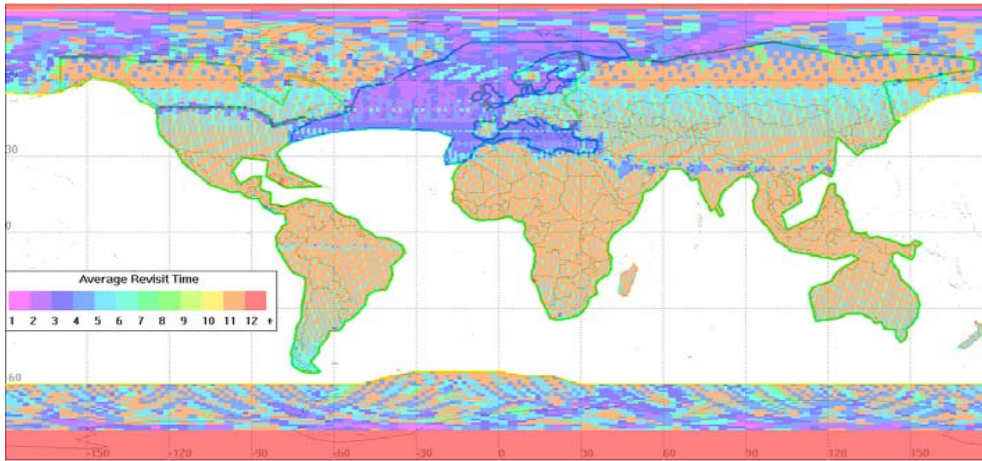

**Average Revisit Time with S-1A + S-1B Satellites**

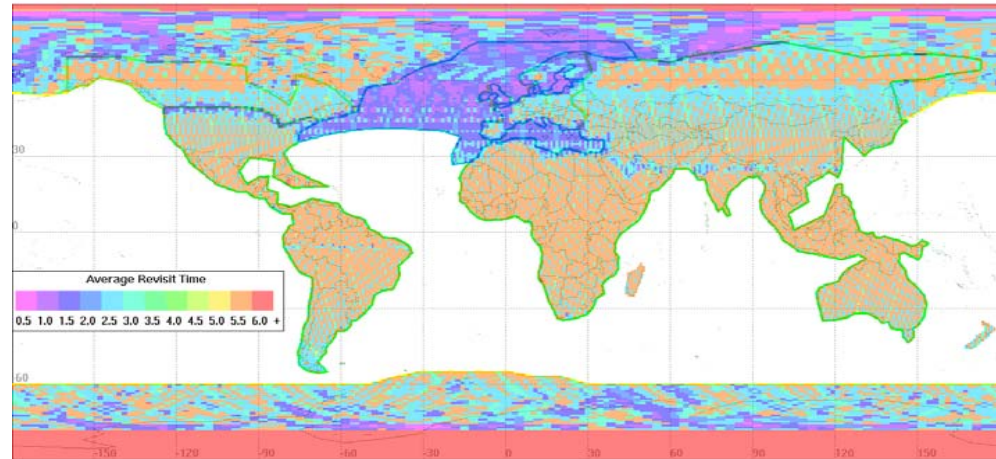

	S-1A Satellite					S-1A + S-1B Satellites				
Complete global coverage	After 12 days					After 6 days				
	Ice	MTZ	Europe	Canada	Rest of Land	Ice	MTZ	Europe	Canada	Rest of Land
Number of acquisitions (range from - to)	1-9	1-6	1-5	1-4	1-6	2-18	2-12	2-10	2-8	2-12
Average Revisit Time [day]	8,0	3,7	5,5	8,2	9,9	5,0	1,9	2,7	4,1	4,9

# Sentinel-1 System Overview

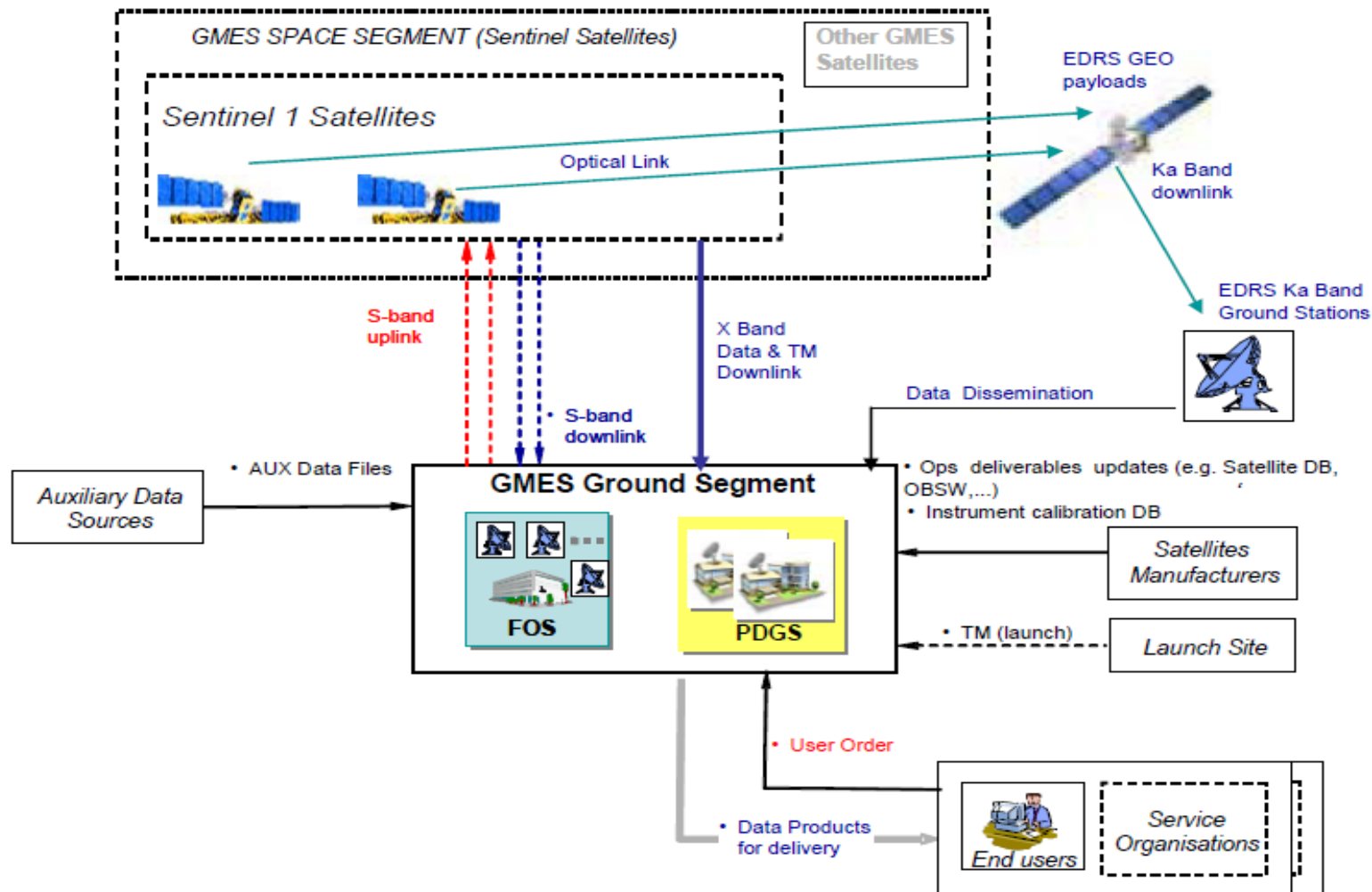

# Sentinel-1 Spacecraft



- Satellite is organized in
  - ✓ Payloads
  - ✓ Subsystems (structure, thermal control, avionics, propulsion, power & electrical, TT&C, Payload Data Handling & Transmission)
- Satellite's mechanical configuration is based on TAS-I Prima multi-purpose platform (bus) used in other SAR missions
  - ✓ COSMO-SkyMed (ASI/IT MOD)
  - ✓ RADARSAT-2 (CSA/MDA)
- Driving requirements for the design of the satellite
  - ✓ Total launch mass (2300 kg)
  - ✓ Lifetime of 7 years with consumables for 12 years
  - ✓ Support SAR instrument transmit peak power (4400 W)
  - ✓ Pointing accuracy ( $\leq 0.01^\circ$ )
  - ✓ Precise orbit determination (10m,  $3\sigma$ )
  - ✓ Tight orbit control (orbital tube of 50m radius (rms))

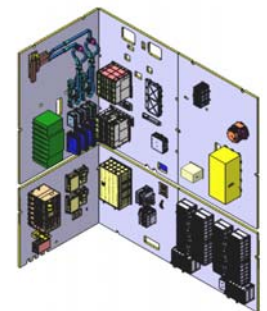
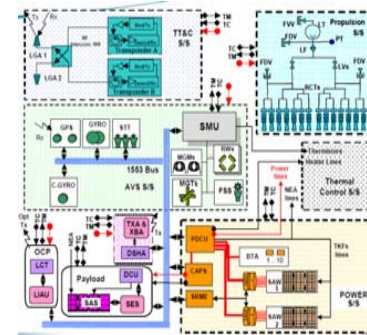
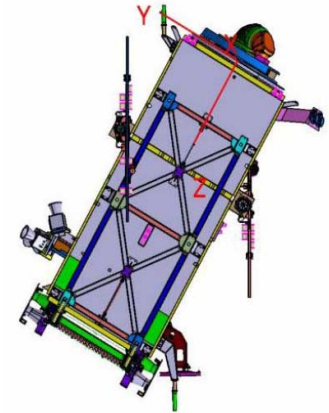



# Sentinel-1 Payload



- C-Band SAR instrument operates at centre frequency of 5.405 GHz

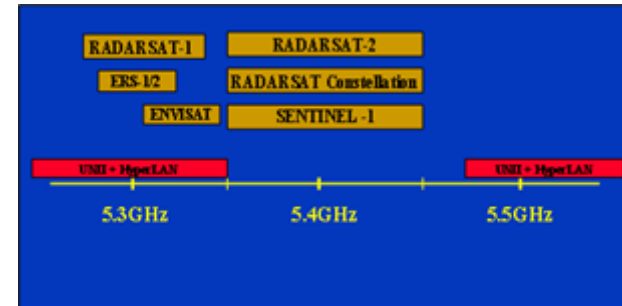
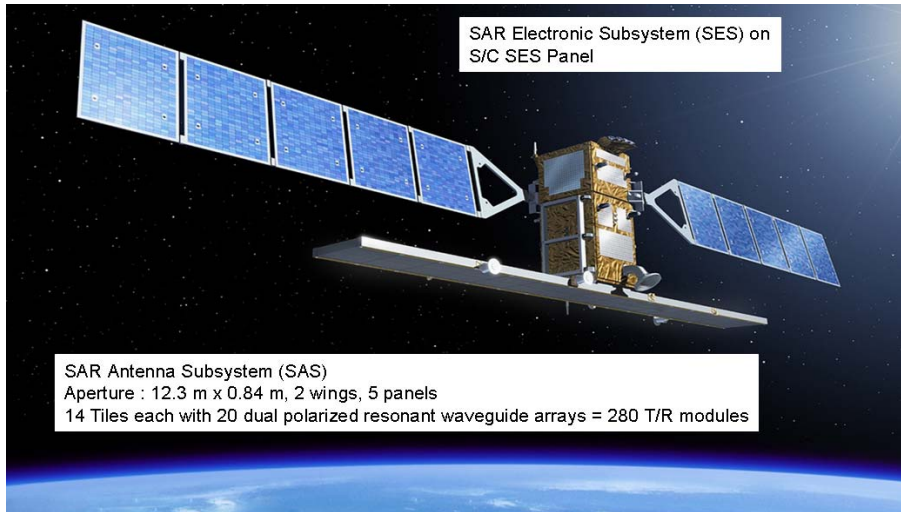

- SAR Payload
  - ✓ SAR Electronic Subsystem (SES)
  - ✓ SAR Antenna Subsystem (SAS) using a phased-array antenna

- On-board data storage capacity (mass memory) of 1400 Gbit
- Two X-band RF channels for data downlink with 2 X 260 Mbps
- On-board data compression using Flexible Dynamic Block Adaptive Quantization
- GPS (2 dual frequency) receiver provide 10 m orbit knowledge and time tag
- Optical Communication Payload for data transfer via laser link with the GEO European Data Relay Satellite (ERDS) system



# Sentinel-1 System Ground Segment



- Ground Segment comprises:
  - ✓ *Flight Operations Segment (FOS)* and
  - ✓ *Payload Data Ground Segment (PDGS)*
- S-band station for TT&C
- X-band receiving stations for data downlink (three stations are required)
- Mission operations lifetime is planned for a period of more than 20 years

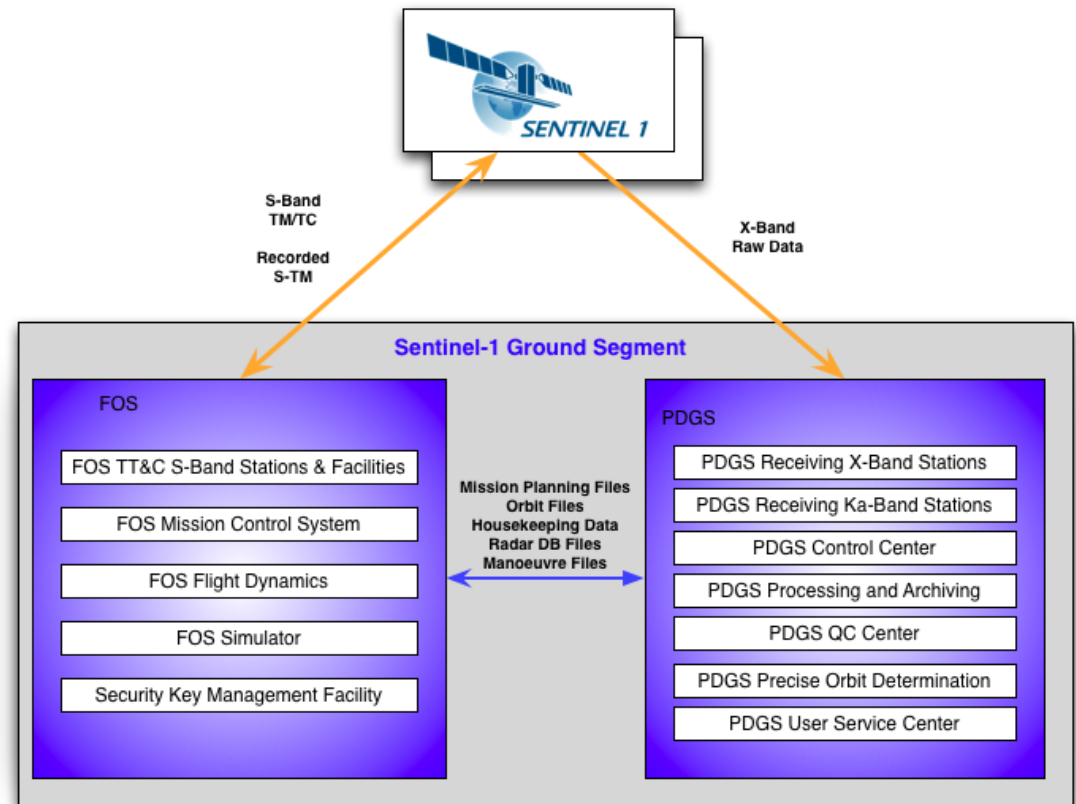

- Instrument provides 4 exclusive SAR modes with different resolution and coverage

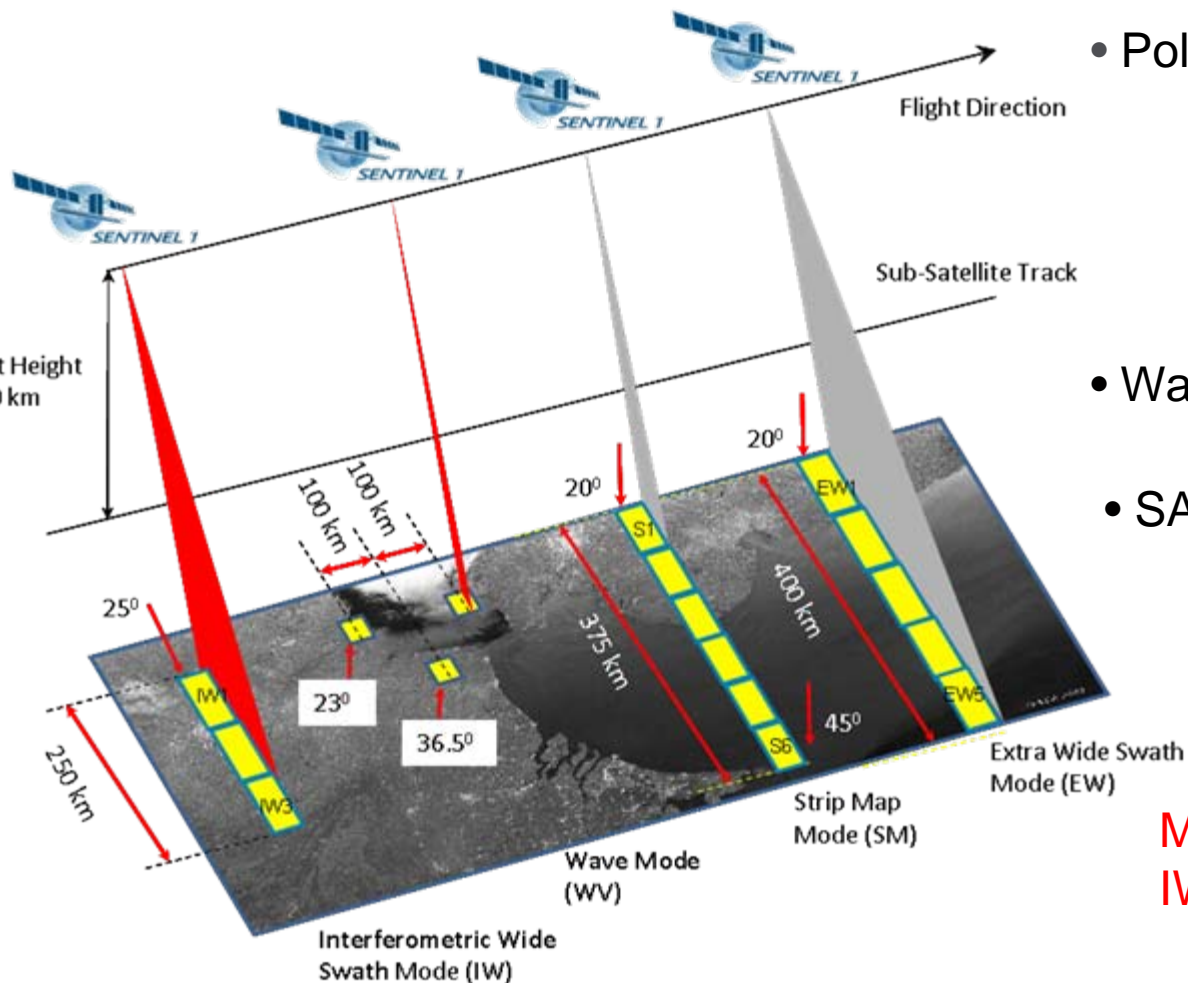

- Polarisation schemes for IW, EW & SM:
  - ✓ single polarisation: HH or VV
  - ✓ dual polarisation: HH+HV or VV+VH
- Wave mode: HH or VV
- SAR duty cycle per orbit:
  - ✓ up to 25 min in any of the imaging modes
  - ✓ up to 74 min in Wave mode

**Main modes of operations:  
IW and WV**

# Sentinel-1 SAR Imaging Modes (2/2)



Mode	Access Angle	Single Look Resolution	Swath Width	Polarisation	Chirp bandwidth [MHz]
Interferometric Wide Swath	> 25 deg.	Range 5 m Azimuth 20 m	> 250 km	HH+HV or VV+VH	56.50 – 42.80
Wave mode	23 deg. and 36.5 deg.	Range 5 m Azimuth 5 m	> 20 x 20 km Vignettes at 100 km intervals	HH or VV	
Strip Map	20-45 deg.	Range 5 m Azimuth 5 m	> 80 km	HH+HV or VV+VH	87.60 – 42.20
Extra Wide Swath	> 20 deg.	Range 20 m Azimuth 40 m	> 400 km	HH+HV or VV+VH	22.20 – 10.40
<b>Image Quality Parameters for all Modes (worst case)</b>					

**Radiometric accuracy (3  $\sigma$ )** 1 dB

**Noise Equivalent Sigma Zero** -22 dB

**Point Target Ambiguity Ratio** -25 dB

**Distributed Target Ambiguity Ratio** -22 dB



# Sentinel-1 SAR Instrument Phase Induced Phase Error Budget over 10 min



Induced Phase error over 10 minutes	Inputs	Unit	3 sigma	Remarks
Internal Cal accuracy, 3 sigma		deg	3.20	Residual error of Internal phase calibration accuracy, worst case of SM and IW modes (see calibration analysis).
TX and RX receive pattern phase random variation			3.12	pattern random variation calculated according para. 6.3.2. TX and RX errors added root sum square. Input from mathematica notebook
Radiator sensitivity	0.1	deg/K		Tile specification
Radiator temperature variation	10	K		Variation over 10 minutes interval
Radiator phase drift over Temperature		deg	1.73	two way, 3 sigma
Connector Sensitivity	0.03	deg/K		
Connector Temperature variation	10	K		Variation over 10 minutes interval
Connector Phase Variation	0.3	deg	0.52	two way, 3 sigma
Phase noise & Frequency Stability of USO		deg	0.94	Remark: Contributios due to frequency drift: stability over 10 minutes=5E-11 plus phase error due to phase noise: S1-AN-ASU-PL-0025, issue 3, predicted value is 0.255 Deg rms
<b>Induced Phase Error over 10 minutes</b>		<b>deg</b>	<b>4.91</b>	<b>3 sigma</b>
<b>Requirement:</b>		<b>deg</b>	<b>5.00</b>	<b>3 sigma</b>

## TOPS (Terrain Observation with Progressive Scans in azimuth) for Sentinel-1 *Interferometric Wide Swath (IW)* and *Extended Wide Swath (EW)* modes

- Provides large swath width (ScanSAR) & enhanced radiometric performance due to reduced scalloping effect
- Important because there is only *1 azimuth look* available  
⇒ radiometric look balancing is not possible

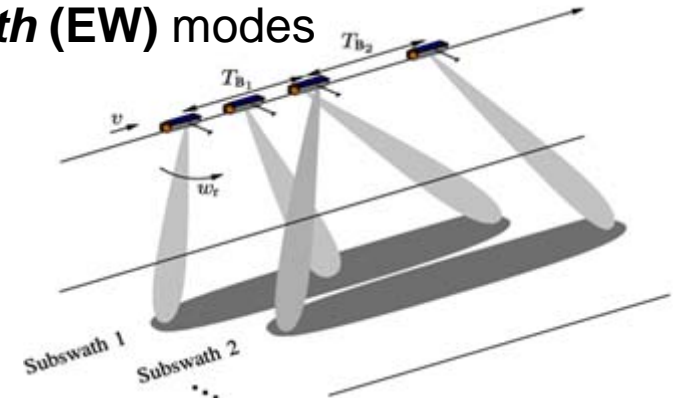

TSX-ScanSAR image

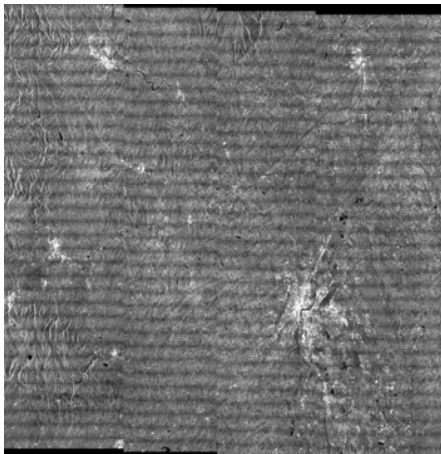

TSX-TOPS image

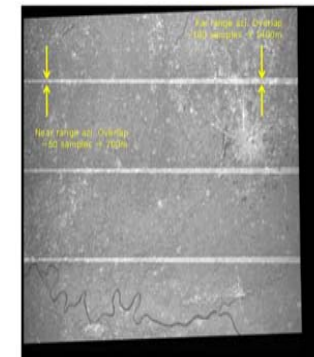
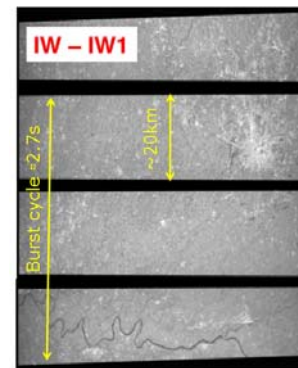
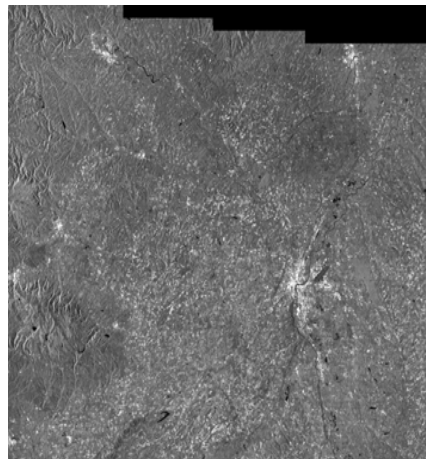

Interferometric Wideswath

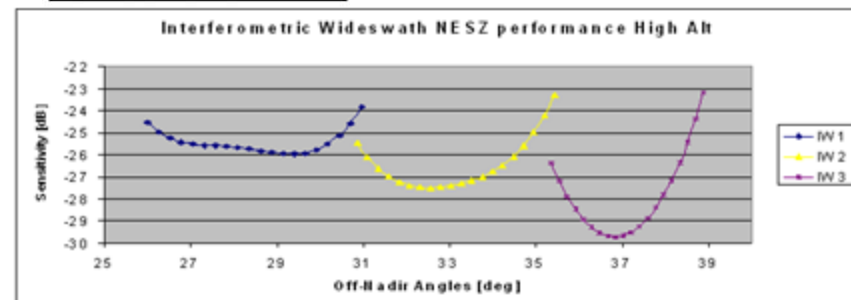

# Sentinel-1 TOPS InSAR Capability



- S-1 TOPS InSAR study based on TerraSAR-X TOPS data, e.g. acquired over the Atacama desert (Chile) having 11-day repeat pass interval

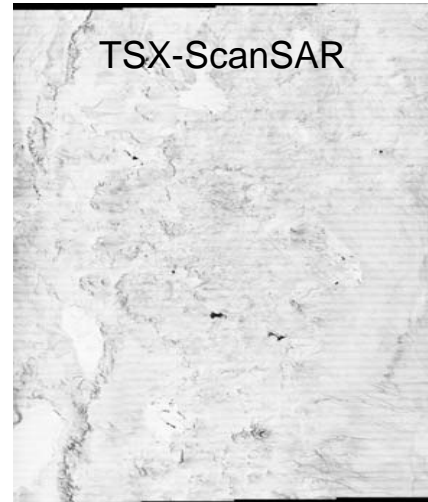
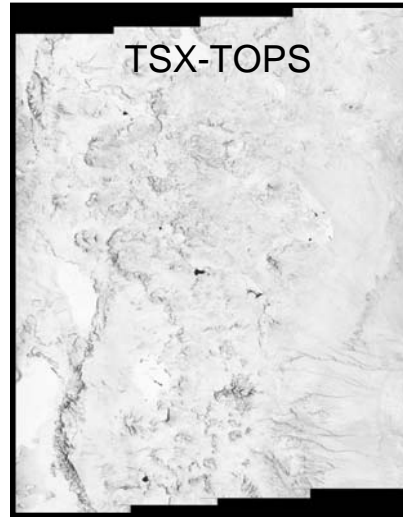
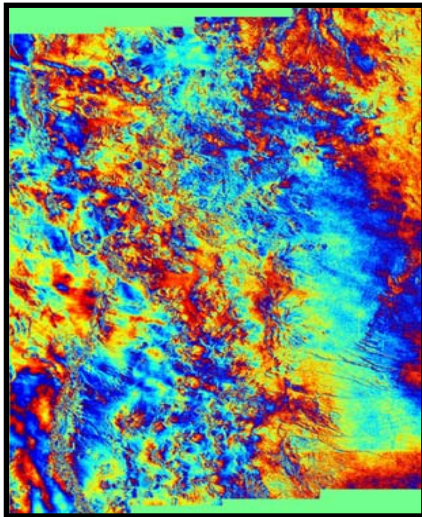

- Coherence loss in ScanSAR due to SNR degradation at burst edges (after azimuth pattern correction)

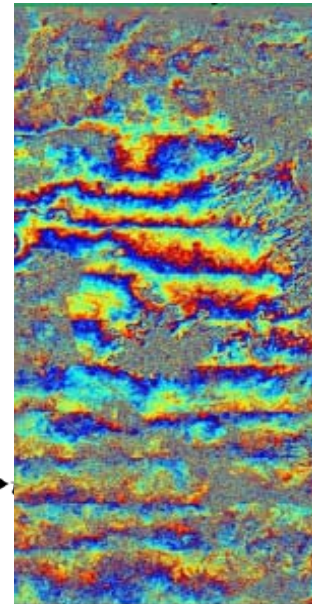

- Azimuth antenna sweeping causes Doppler centroid variations of about 5.5 kHz
- Introducing an azimuth phase ramp (azimuth fringes) for small co-registration errors
- Requires azimuth co-registration to be better than 0.001 samples in order to obtain phase error less than 3 deg.

$$\phi_{az_{err}} = 2\pi f_{DC} \Delta t$$

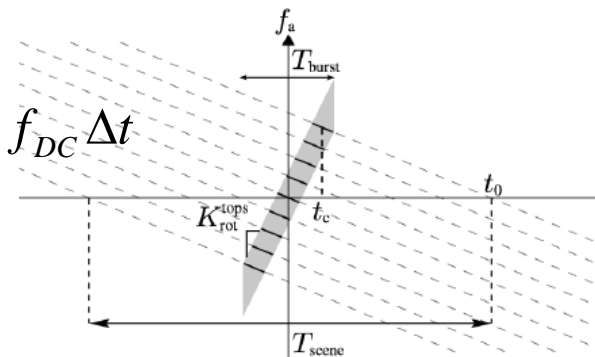

# TOPS Burst Synchronization

- TOPS interferogram generation requires burst synchronization of repeat-pass datatakes

- TOPS burst duration for:

- ✓ EW: 0.54 s (worst case)
- ✓ IW : 0.82 s (worst case)

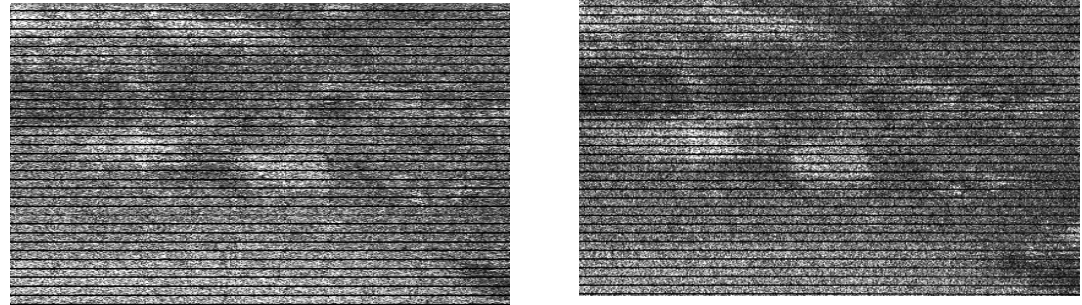

- Requirement for Burst Synchronization:  $\leq 5\text{ms}$

- Event Control Code (EEC) for datatake (Measurement Mode)

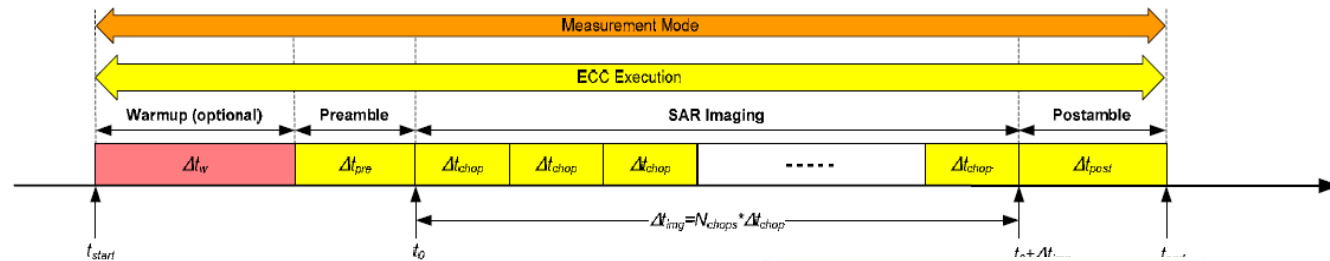

- Instrument schedule execution is using *Orbit* (on-board) *Position Schedule (OPS)* commanding based upon location
- Location for OPS is not specified by lat. and long. (e.g. WGS 84), but by means of *OPS angle* (angle in orbital plane between Reference plane and desired location on orbit)

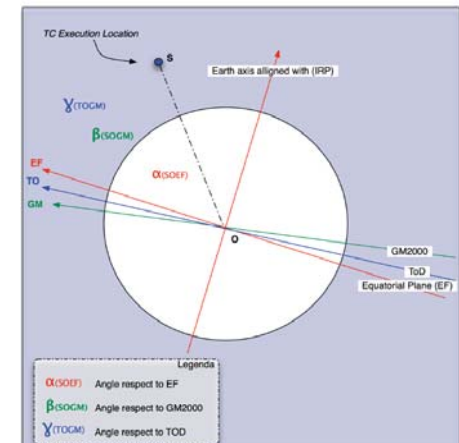



# Sentinel-1 Orbital Tube and InSAR Baseline



- Satellite will be kept within an *Orbital Tube* around a Reference Mission Orbit (RMO)
- *Orbital Tube* radius (statistical) is 50 m (rms)
- Orbit control is achieved by applying *cross-track dead-band control* at the most *Northern point* and *Ascending Node* crossing

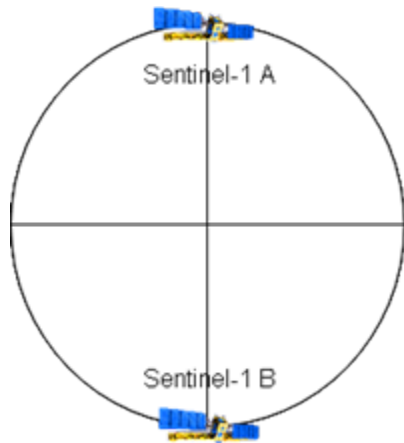
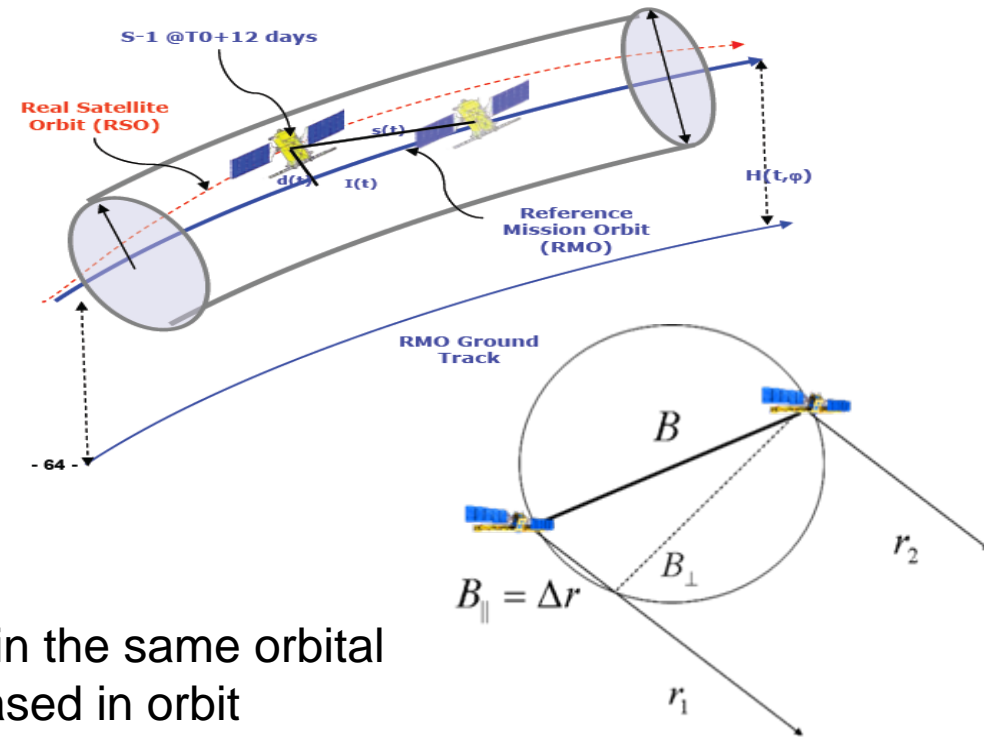

- Sentinel-1 A & B will fly in the same orbital plane with *180 deg.* phased in orbit
- *12-day repeat* orbit cycle for each satellite
- Formation of SAR interferometry (InSAR) data pairs having time intervals of *6-days*

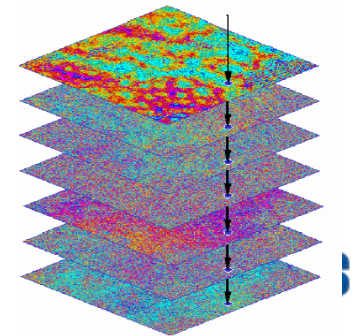

# Sentinel-1 Attitude Steering Modes

## Roll-steering mode

- Sensor altitude changes around the orbit
- Introduction of additional satellite roll angle depending on latitude to maintain a quasi “constant” slant range

at  $H_{\min} = 697.6 \text{ km} \Rightarrow \theta_{\text{off-Nadir}} = 30.25^\circ$

at  $H_{\max} = 725.8 \text{ km} \Rightarrow \theta_{\text{off-Nadir}} = 28.65^\circ$

### Advantages:

- Single PRF around orbit per swath or subswath (except for S5 (S5-N and S5-S))
- Fixed set of constant Elevation antenna beam patterns

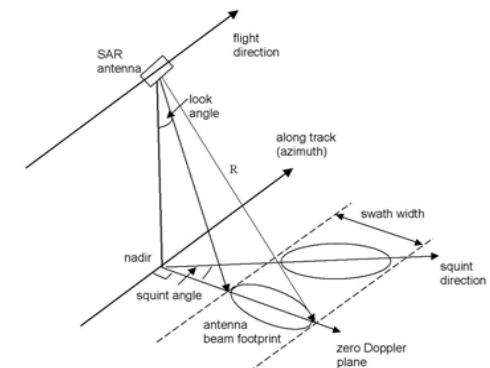
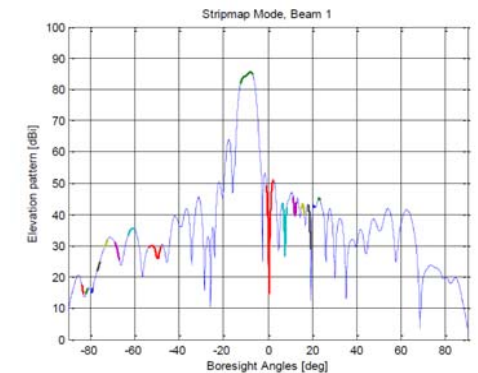
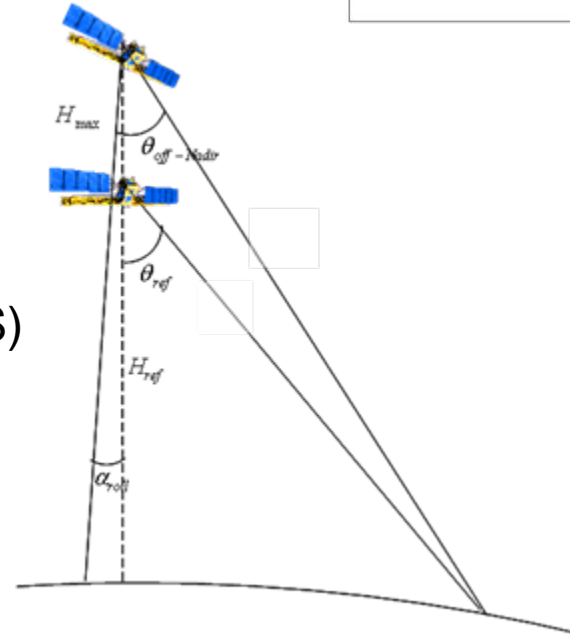
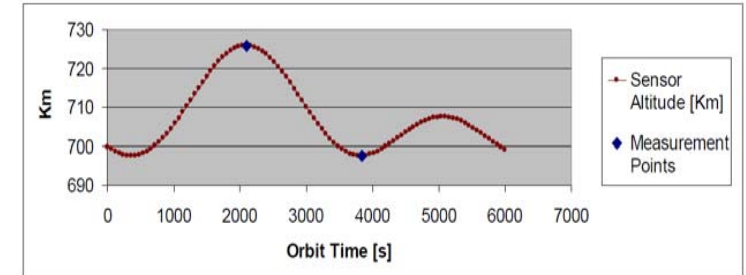

## Total zero-Doppler steering mode

- Yaw and pitch adjustments around the orbit to account for Earth rotation effect
- Provides Doppler centroid at about 0 Hz

# Sentinel-1 Commissioning Phase Activities



**End-to-End System performance verification and calibration**, involving ESA (ESTEC, ESRIN, ESOC) and external experts

- Check-out of spacecraft and ground segment
- In-orbit verification of instrument performance and calibration
- In-orbit calibration activities comprise:
  - ✓ internal instrument calibration (using PCC techniques, calibration pulse analysis)
  - ✓ pointing calibration (using data acquired over rainforest and transponder sites)
  - ✓ geometric calibration
  - ✓ antenna model verification
  - ✓ radiometric calibration
  - ✓ polarimetric calibration
  - ✓ ***interferometric verification***
- Level 0 and Level 1b SAR product verification (i.e. wrt SAR instrument performance)

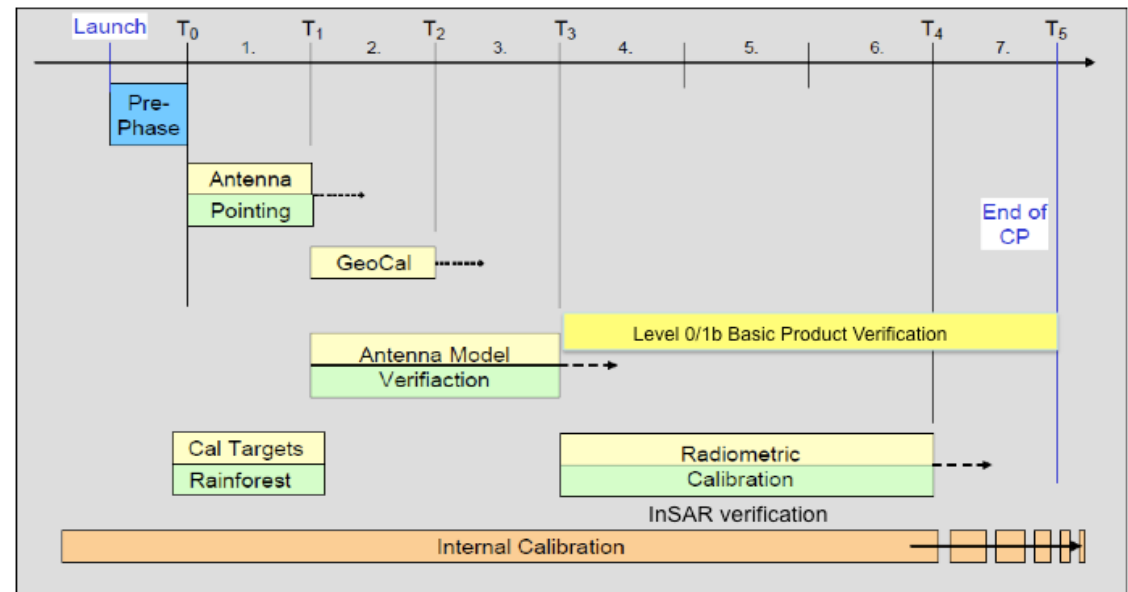

3 months

# Sentinel-1 Interferometric Verification



- Systematic generation of repeat-pass interferograms over dry test sites (e.g. Lake Uyuni, Bolivia, Atacama desert, Chile)
- Monitoring of instrument phase stability over 25 min datatake
- Measurement of InSAR phase stability over Corner Reflector site (at DLR)
- Measurement of phase stability in overlap area between bursts and sub-swaths
- Verification of InSAR baseline (round orbit)
- Verification of TOPS burst synchronization

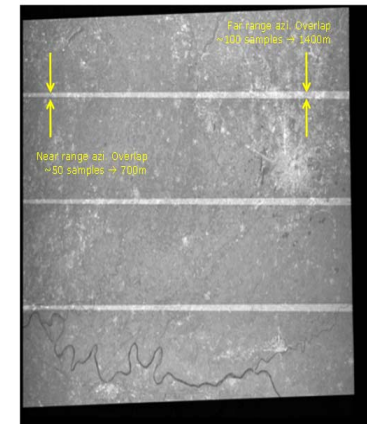

# Sentinel-1 Commissioning Phase Analysis Facility (CPAF)

- Set of data analysis tool boxes used by the Commissioning Phase Team

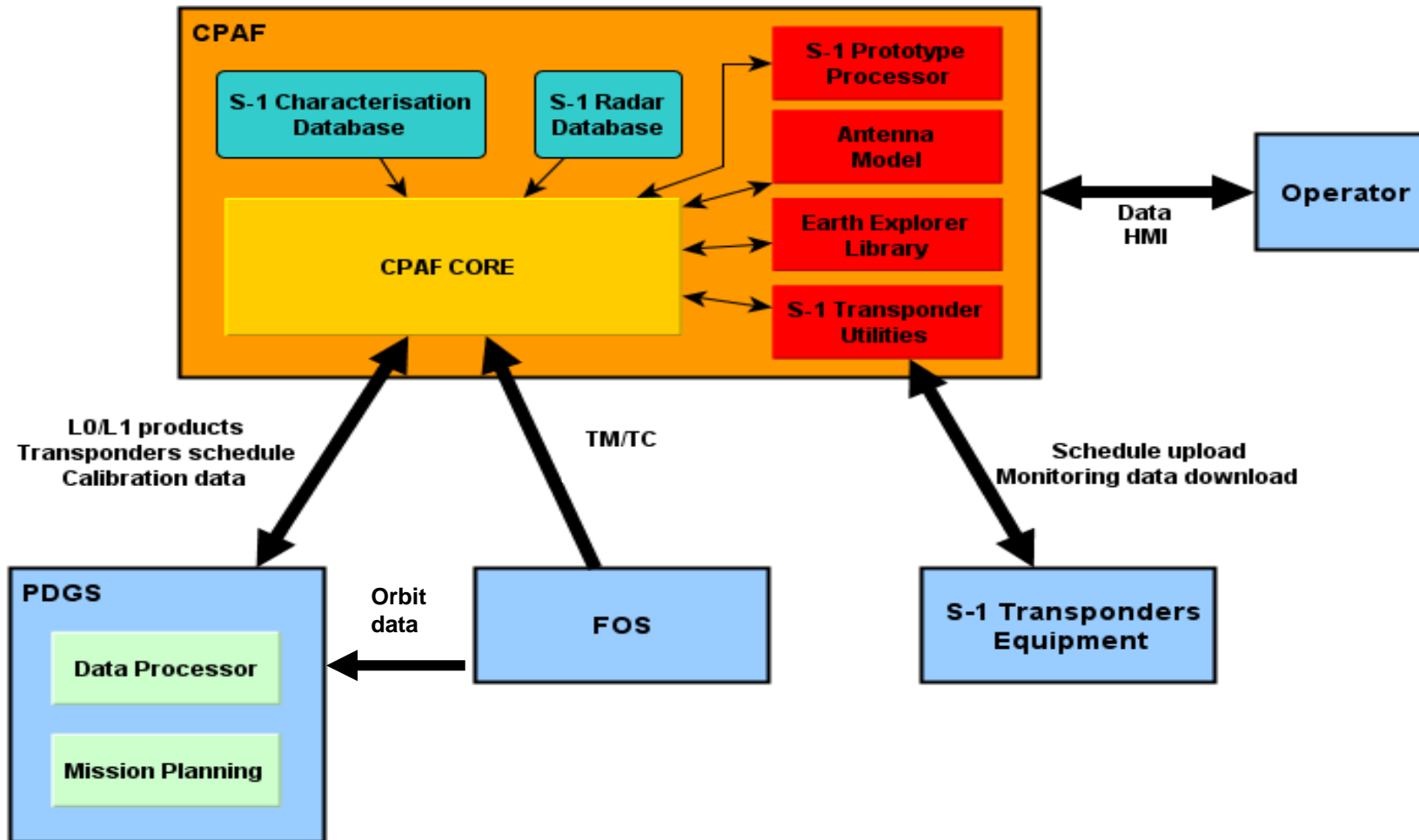

- Sentinel-1 will provide routinely and systematically SAR data for operational monitoring tasks especially for GMES Services and National services
- Using the same SAR imaging mode (instrument settings, e.g. IW) facilitates the build-up of *data time series* for long-term continuity of observations with *equidistant* and *short time intervals* (*interferogram stacks*)
- TOPS burst synchronization to facilitate image co-registration
- Sentinel-1 A & B will fly in the same orbital plane with *180 deg.* phased in orbit, each with *12-day repeat* orbit cycle
- Formation of InSAR data pairs having time intervals of *6-days*
- Small orbital tube with radius of 50m (rms) provides small InSAR baselines

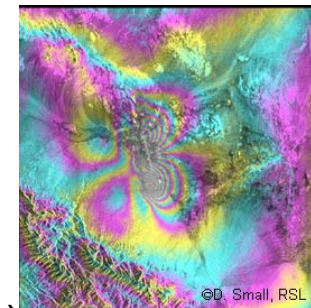
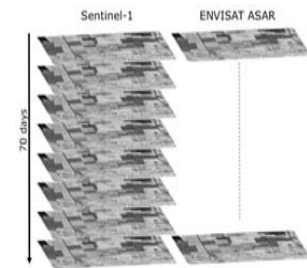
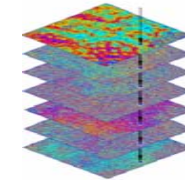

## ⇒ Coherent Change Detection Monitoring applications

Monitoring of geophysical phenomena related to surface displacements and/or changes in scattering properties having different time scales (mm/year – m/day)

- Collaboration with CSA's RADARSAT Constellation Mission (RCM) to facilitate *multi-satellite InSAR monitoring* (requires harmonization of data acquisition strategies and interfaces)

