

esa BR – 75

April 1991

**The Data Book of ERS – 1  
The European Remote Sensing Satellite**



FSABR00075

**The European Remote Sensing Satellite — ERS-1  
Data Book**

**A summary of the technical elements  
of the ERS-1 spacecraft  
and its payload**

**written by**

**Members of the ESA Directorate  
for the Observation of the Earth and its Environment**

**The editor and authors wish to thank those companies and institutes which have provided illustrations and photographs used in this book, and for which on occasions a specific acknowledgement has not been possible.**

*It is not the purpose of this publication to cover such subjects as mission objectives, the processing and exploitation of ERS-1 payload data, nor to cover future Earth Observation programmes, but readers who would like to have more information should read ESA Bulletin No. 65 which was a special issue on ERS-1. Copies may be ordered, free of charge, from ESA Publications Division, ESTEC, Noordwijk, The Netherlands, while stocks remain.*

**Contributors (in alphabetical order)**

D. Andrews	B. Marcorelles
E. Attema	M. McCraig
G. Dieterle	C. McCarthy
J. Dodsworth	M. McKay
P. Dubock	K. McMullen
G. Duchossois	B. Pieper
P.G. Edwards	P.-Y. Pouvreau
R. Francis	R. Wall
G. Graf	F. Wechsler
A. Lefebvre	R. Zobl
J. Louet	

*Technical coordination:* Richard Francis

*Edited by:* Norman Longdon

*Graphics by:* Willem Versteeg

*ESA Photographs by:* Anneke van der Geest

*Montage by:* Corinne Liger

*Published by:* ESA Publications Division  
ESTEC, Noordwijk  
The Netherlands

*Copyright:* © European Space Agency 1991

*Price:* 20 Dutch Guilders

**ISSN 0250-1589**

**ISBN 92-9092-079-3**

---

# ERS-1 DATA BOOK

---

## Contents

Forward	
<i>R. Zobl — ERS-1 Project Manager</i>	
Chapter 1 Introduction	1
Mission Objectives	1
A Multi-Disciplinary Mission	1
Spacecraft and Payload System Outline	2
Launch Method	4
Chapter 2 Programmatic	5
Overall Schedule	5
Assembly, Integration, and Verification	6
Preparation for the Receipt and Use of ERS-1 Data	7
Launch and Early Orbit Phase	8
Deployment Method	10
Special Technologies and Test Equipment	12
Chapter 3 The Spacecraft Subsystems	15
Structure	15
Power Supply	17
Pyrotechnics	17
Attitude and Orbital Control	18
Thermal Control	19
On-Board Data Handling and Telemetry	20
Chapter 4 Scientific Instruments	23
Active Microwave Instrument (AMI)	23
Radar Altimeter (RA)26	
Along-Track Scanning Radiometer and Microwave Sounder (ATSR-M)	28
The Laser Retro-Reflector (LRR)	29
Precise Range and Range-rate Equipment (PRARE)	29
Chapter 5 Calibration and Validation	31
Engineering Calibration of the Active Microwave Instrument	31
Engineering Calibration of the Radar Altimeter	32
Engineering Calibration of the Along-Track Scanning Radiometer	34
Engineering Calibration of the Precise Range and Range-Rate Equipment	35
Geophysical Calibration of ERS-1	36

---

## ERS-1 DATA BOOK

---

### Foreword

This Data Book has been prepared in April 1991, some weeks before the scheduled launch of ERS-1 from Kourou. At this time we are on schedule for a launch at 01:46 UTC on 4 May 1991; all of the intricate plans and activities of the last decade at last coming together.

We, at ESA, in the course of this project, have worked together with 3 000 engineers and scientists in Europe, Canada, and other parts of the world, to bring a dream to reality. It is impractical to name names, but without their determination we would never have made it.

Our work is nearly finished, and after in-orbit commissioning, we, the engineers, will hand the machine over to the scientists and other users, who will have the responsibility of proving the worth of what we have made.

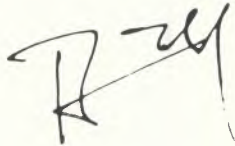

R. Zobl  
Project Manager ERS-1



---

# ERS – 1 DATA BOOK — Chapter 1 — Introduction

---

## MISSION OBJECTIVES

It is particularly apposite that at a time when nations across the globe are becoming increasingly conscious of the need to know more of the underlying principles and details about the Earth and its environment as a system, yet have only a rather generalised idea of what is involved, the European Space Agency should be able to offer the most advanced remote sensing satellite ever designed for peaceful purposes.

Although it is apparent that the human race faces a number of potentially very serious problems of an environmental nature, including climatic changes due to the greenhouse effect, ozone depletion, and desertification of arable land, even more fundamental to our understanding of the world in which we live is the need for both global and repetitive observations to build the necessary data banks from which trustworthy analyses can be made.

The first European Remote Sensing Satellite (ERS-1), from its Sun-synchronous orbit, and with its unique set of all-weather microwave instruments, will make a substantial contribution to the scientific study of our environment. With an operational life of between two and three years, those all-important criteria – global and repetitive coverage – will be met.

### ERS-1: A multi-disciplinary mission

The first European Remote-Sensing Satellite is the forerunner of a new generation of space missions planned for the 1990s. It will use advanced microwave (radar) techniques to make global measurements and imaging to take place regardless of cloud and sunlight conditions. In addition, ERS-1 will measure many parameters not covered by existing satellite systems, including those of sea state, sea surface winds, ocean circulation and sea and ice levels, as well

as all-weather imaging of ocean, ice and land. It will also measure the sea's surface temperature with greater accuracy than any of the current space systems. Data will be collected from remote areas such as the polar regions and the southern oceans, for which there has been a dearth of information so far.

The ERS-1 mission will provide data that will contribute to:

- improved understanding of ocean-atmosphere interactions in climate models;
- major advances in our knowledge of ocean circulations and the transfer of energy;
- more reliable estimates of the mass balance of the Arctic and Antarctic ice sheets;
- better monitoring of dynamic coastal processes and pollution; and
- improved detection and management of land-use change and cover.

Part of the mission objectives takes account of the need for information on several parameters, such as wind velocities, sea-state, sea-ice distribution, to be in the hands of meteorologists, other scientists, and operators responsible for shipping, fishing, and offshore activities including oil and gas rigs for shipping and offshore activities within a very short time; a matter of hours.

Although ERS-1 will be primarily concerned with sea, ice, and coastal area data, its versatility is such that other objectives can be met, particularly high-resolution radar imaging of the Earth's surface, to provide unique data sets for land-resource management, including both renewable and non-renewable resources. Last but not least, thanks to its altimetric and precise tracking data, ERS-1 will provide very valuable information for the understanding of the Earth's interior and for geodetic applications.

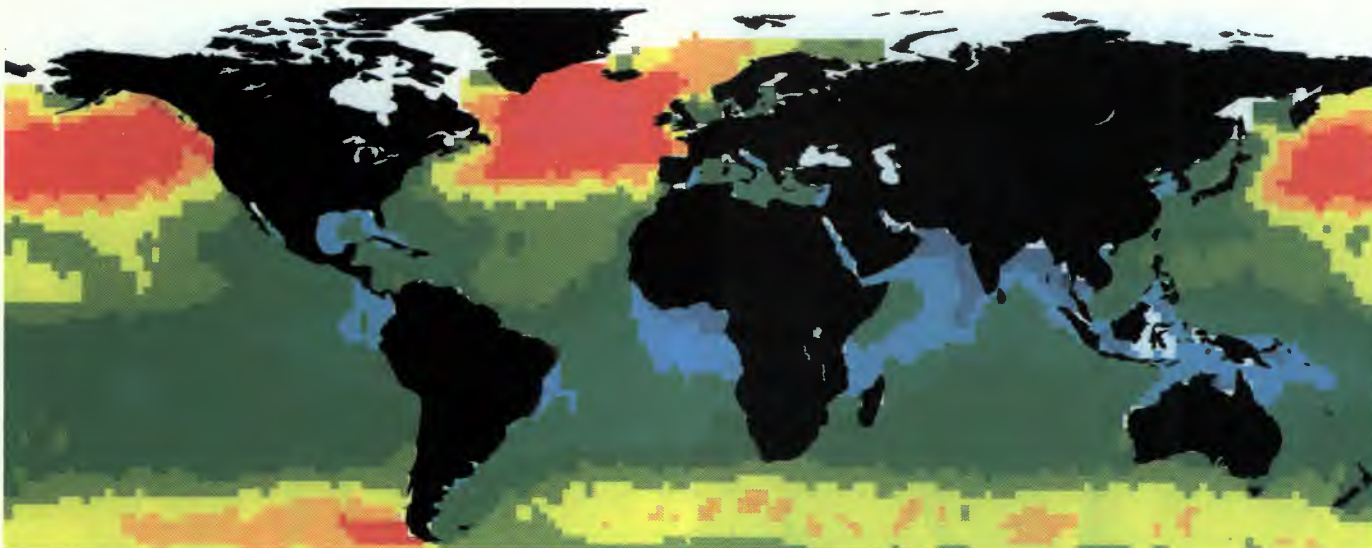

Average wave heights measured by GEOSAT Altimeter(courtesy IOSDL)

---

# ERS-1 DATA BOOK

---

## ERS-1 SPACECRAFT AND PAYLOAD SYSTEM OUTLINE

In order to be able to make all of the measurements necessary to meet the mission objectives outlined on the previous page, and to provide them globally, at all times of day and regardless of cloud conditions, the principal elements of the ERS-1 payload are active microwave instruments, or radars.

To achieve the global coverage required, ERS-1 will be placed into a polar orbit with a mean altitude of about 780 km. From this altitude powerful radar pulses are needed to provide sufficient illumination of the Earth's surface to produce detectable echo signals. Large antennas are needed on the spacecraft to pick up the returning signals.

Consequently, the satellite has to be very large, and weighs about 2 400 kg, of which 1000 kg is taken up by the payload. The payload consumes about 1 kW of electrical power when in full operation.

The antennas, once deployed, will be up to 10 m long; the main payload support structure has a 2 m x 2 m base and is some 3 m high. The payload is supported by a platform module – derived from the French national Spot programme – which supplies the payload's electrical power needs, about 1 kW when in full operation, attitude and orbit control, and overall operational management.

This module is roughly equivalent in size to the payload itself and is equipped with a deployable 12 m x 2.4 m solar array.

The largest of the sensors, the Active Microwave Instrument (AMI) will be capable, in its imaging mode, of producing highly detailed radar images of a 100 km strip on the Earth's surface. This mode is also known as the Synthetic Aperture Radar or 'SAR' mode. Because this mode will consume a large amount of energy and produce a vast amount of data, which cannot be stored on board, it will only be used only when passing over a ground station capable of receiving the data. Power needs are such that the SAR mode is only used for periods of approximately 10 minutes during each orbit.

The same instrument has alternative global measurement modes, namely the 'Wind (or Scatterometer) Mode', in which the wind speed and direction at the sea-surface can be measured over a 500 km swath, and a 'Wave Mode', which will provide small radar images at 200 km or 300 km (selectable) intervals. These can be used to generate ocean-wave spectra, showing wave energy as a function of wavelength and direction.

A second instrument, the Radar Altimeter, will provide highly precise measurements of the satellite's height above the ocean, ice and land surfaces. To exploit these height data successfully in the study, amongst other things, of global ocean circulation and height profiles across the ice caps, an exact determination of the satellite's orbit is needed. This is derived from the onboard tracking systems. These are a laser retroreflector, a passive device used by ground-based satellite laser-ranging systems, and the PRARE instrument, which is a two-way microwave ranging system that uses small, dedicated ground stations.

Another payload instrument is the Along-Track Scanning Radiometer (ATSR), which has two elements. Detailed images of the sea surface will be made by an infrared scanning radiometer, which will allow extremely precise measurements of sea-surface temperature. The other element is a passive microwave radiometer, which will be used to determine the water-vapour content of the vertical column of the Earth's atmosphere passing beneath the satellite.

The large amounts of data from these instruments will be transmitted to the ground via the Instrument Data-Handling and Transmission (IDHT) Subsystem. This includes two high-capacity onboard tape recorders to store the data being gathered whilst the satellite is outside the zones in which the various ground stations can accept the data.

### The platform

The spacecraft platform provides the major services required for satellite and payload operation. These include attitude and orbit control, power supply, monitoring and control of payload status, telecommunication with ground stations for telecommand reception and telemetry of payload and platform housekeeping data. The platform also houses the PRARE instrument as a passenger.

The platform has been modified with respect to the Spot programme in which it was developed as a multimission concept, to meet the unique needs of the ERS-1 mission. The major modifications have included extension of the solar-array power and battery energy-storage capability, modification of the attitude control subsystem to provide yaw steering and geodetic pointing, and the development of new software for payload management and control.

An exploded view of the spacecraft and payload is given on the next page, and the subsystems of the spacecraft are described in more detail in chapter 3, and the payload instruments in chapter 4.

# ERS-1 DATA BOOK

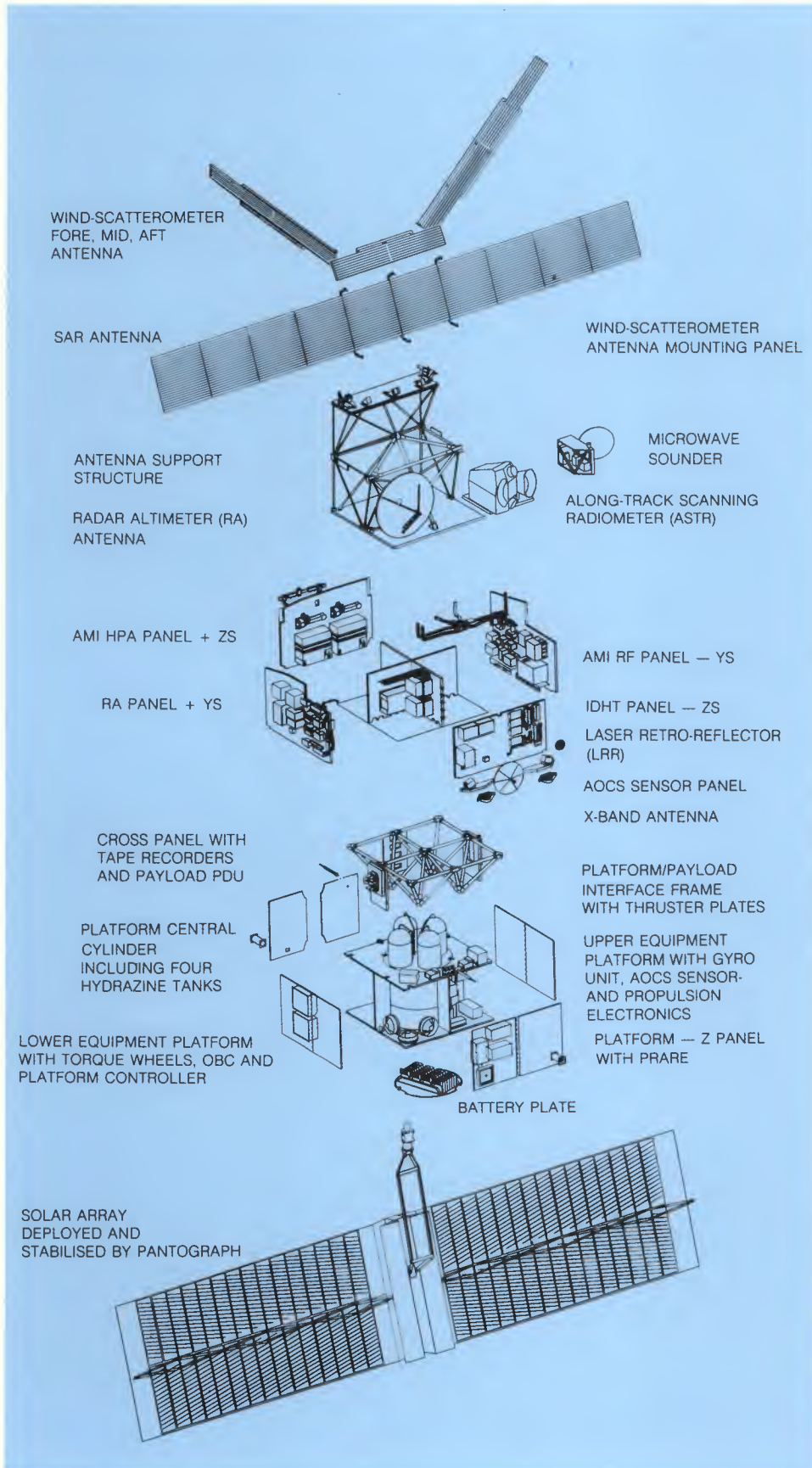

Exploded view of the ERS-1 satellite

## Legend

- SAR: Synthetic Aperture Radar
- AMI: Active Microwave Instrument
- HPA: High Power Amplifier
- ZS: Satellite Z Axis
- YS: Satellite Y Axis
- IDHT: Instrument Data Handling and Transmission
- AOCS: Attitude and Orbital Control System
- PDU: Power Distribution Unit
- OBC: On Board Computer
- Z Panel: Panel on -Z side
- PRARE: Precise Range And Range-Rate Equipment



# ERS-1 DATA BOOK

## LAUNCH METHOD

The Ariane 4 family of launchers has been largely responsible for the leading position which Europe holds in the highly competitive satellite launcher market. ERS-1 will be launched on the simplest version of this six-version launch vehicle (if a satellite launcher can ever be called simple). The Ariane 40 model will lift ERS-1, with its launch mass of 2 400 kg into a Sun-synchronous orbit. This mass does not fully use the capacity of the Ariane, and the opportunity has been taken to launch, as an auxiliary payload, four microsatellites.

Microsatellites			
name	from	function	mass
ORBCOMM-X	Orbital Sciences Corp. (USA)	UHF/VHF communications technology	20.90 kg
SARA	ESIE ESPACE Club Aérospatiale (F)	Decametric radio observations of Jupiter	26.60 kg
TUBSAT	TU Berlin (D)	Communications & technology	38.50kg
UoSAT-F	University of Surrey (UK)	Communications & technology demonstration	50.00 kg

ERS-1 will be launched from the ELA 2 launch facility which is part of the ESA launch site at Kourou in French Guiana. The satellite will be prepared for launch in a preparation complex, so designed that satellite operations can proceed right up to the final stage of encapsulation in the fairing. The 'fairing and payload' assembly is then transported from the preparation buildings to the launch area. Meanwhile, in the assembly dock of the launch site, the launcher's stages and vehicle equipment bay are assembled, and undergo preliminary checks. The final phase, in which the launcher and the fairing with the satellites are fitted together, and checked out in the launch area is reached.

The countdown starts some 48 hours before launch with the filling of the propellant tanks with UH<sub>2</sub> and N<sub>2</sub>O<sub>4</sub>, and starting three hours before launch the tanks of the third stage are filled with the cryogenic propellants — liquid hydrogen and oxygen. Final checks are made, and the 'synchronised sequence' governed entirely by the control centre computers begins at H<sub>0</sub> minus six minutes.

For details of the launch and early orbit sequence which is unique for ERS-1 see chapter 2.



Ariane 4 launcher — first successful launch of an AR40 — 1990

# ERS - 1 DATA BOOK — Chapter 2 — Programmatic

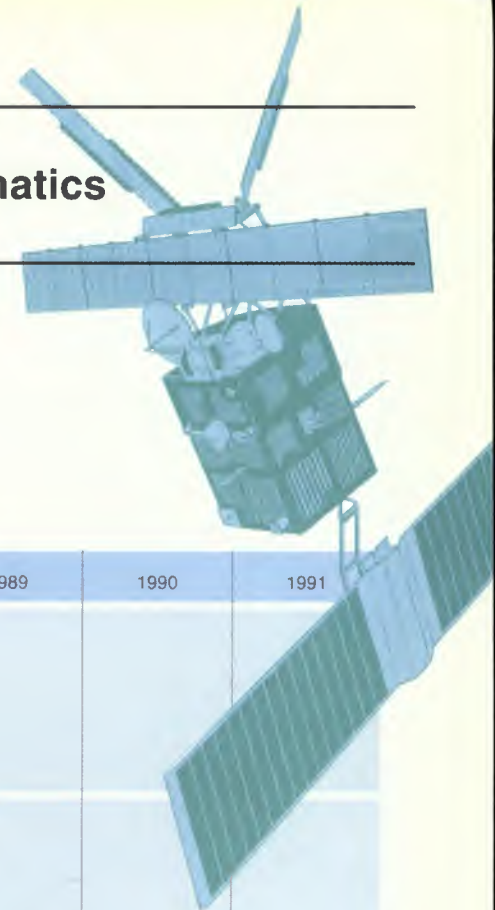

## OVERALL SCHEDULE

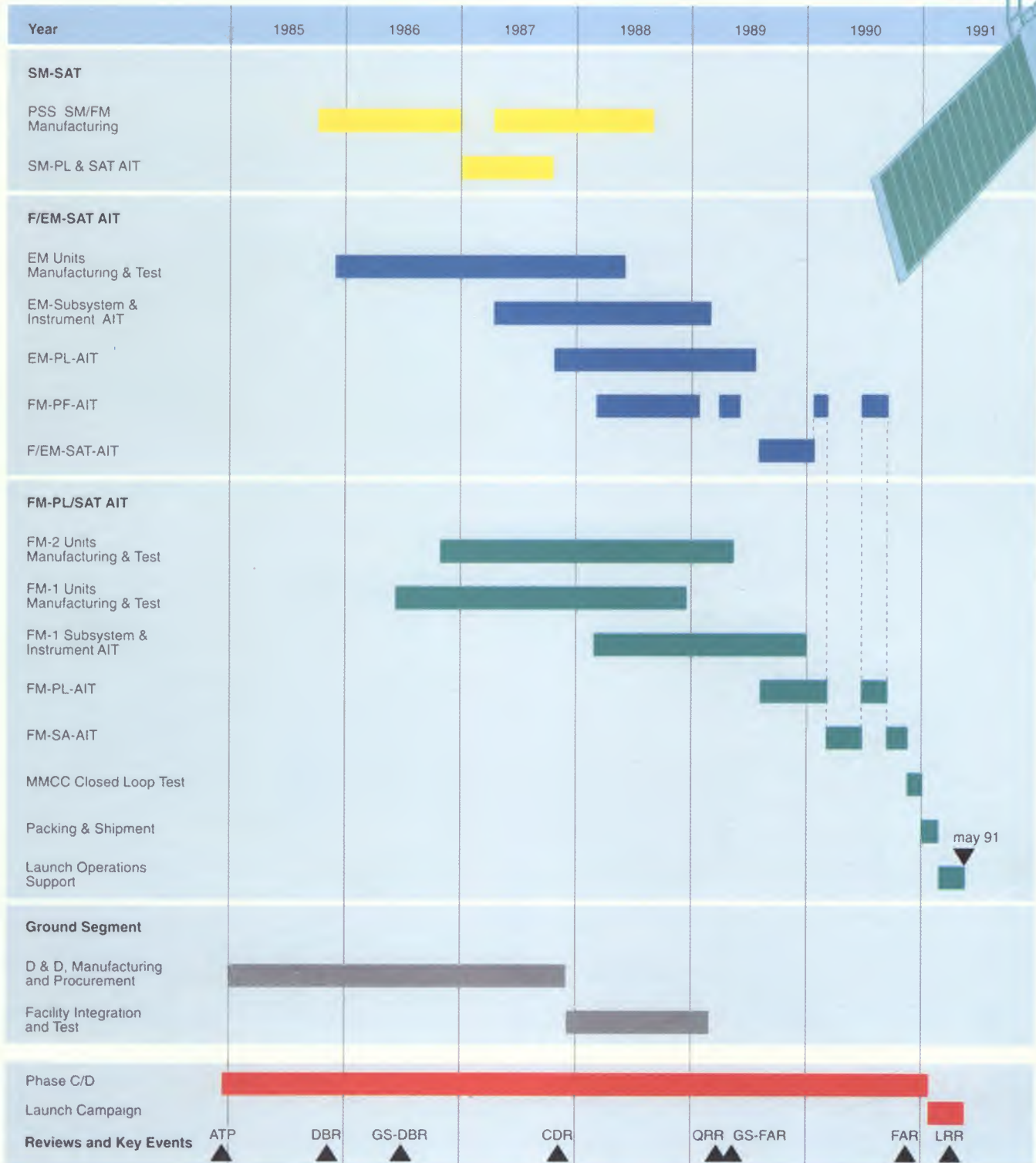

# ERS-1 DATA BOOK

## ASSEMBLY, INTEGRATION, AND VERIFICATION

For the design, development and verification of ERS-1, a three model assembly, integration, and test programme was conducted.

### Structural Model (SM) programme

The structural model consisted of the structural model payload, and a modified SPOT platform structural and thermal model. This was used to verify the mechanical design and interfaces, the payload harness routing and layout, and to qualify the structure.

### Flight/Engineering Model (FEM) programme

By using an FEM in the sequence the classical pattern of AIV activities was modified. The FEM included the Engineering Model (EM) of the payload, and the Flight Model (FM) of the platform.

With this configuration, following the FM platform acceptance programme, and the EM payload integration and test results, the electrical design and compatibility were verified, and the performance of the instruments was demonstrated as far as non-flight build units would allow. The payload thermal control subsystem was also qualified. This configuration was used for the unique RFC test in which all the equipment was operated, using the relevant antennas in the flight configuration.

### Flight Model (FM) programme

Finally the Flight Model programme brought together the flight model payload and the flight model platform.

The objectives of the FM programme included verifying

- final mechanical and electrical interfaces
- full functional and performance under ambient and thermal vacuum conditions
- structural acceptance (satellite level)
- thermal/vacuum acceptance (payload level)
- performance of the release and deployment system of the antennas
- flight software
- the Mission Management and Control Centre (MMCC) operations.

## Integration

The same sequence and test philosophy established and verified during the payload engineer model programme was followed for the payload flight model. From the lessons learnt updates of electrical and mechanical procedures and test software were implemented together with modifications to the test equipment.

To build up all units and subsystems to a fully operational system special emphasis was put on:

- verifying all subsystem external interfaces, operational

- requirements and system compatibilities
- verifying instrument performance and establishing a database for the subsequent test programme
- verifying finally the electrical and mechanical equipment, its interfaces, compatibility and operational performance.

As examples of the AIV sequences, the following charts and graphs give more details.

SYSTEM MODEL	STRUCTURE MODEL			ENGINEERING MODEL			FLIGHT MODEL			NOTES
	FF (ASTM)	PL (SH)	SA (SH)	FF (FM)	PL (EM)	SA (FEM)	FF (FM)	PL (FM)	SA (FM)	
INTEGRATION MECH. I/F's, DIMENSIONS	T	T	T	T	T	T	T	T	T	C = ANALYSIS
INTEGRATION ELECTR. I/F's				T	T	T	T	T	T	T = TEST/OKAS.
BASE C.O.C., H.O.I.	T	T	C				T	T	C	A = ACCEPTANCE
LEAK				T			T			Q = QUALIFICATION
ALIGNMENT	1)	T	T				T	T	T	
MODAL SURVEY			1)							1) Verified on SPOT Programme
STATIC LOAD		Q*)								5) Manual Deployment for RFC Test
SINE/ACOUSTIC			Q						A	
ANTENNAS RELEASE			T*)	T		T*)			T	2) Structural math. model Verificat.
DEPLOYMENT				T					T	6) Full Release/Deployment of all Antennas
BNC				T	T	T			T	3) Centrifuge Test
FUNCT. PERFORMANCE				T	T	T	T	T,)	T	4) SCATT Release/ Shock Measurement
COMPATIBILITY						RFC	T			6) Full Release/Deployment of all Antennas
THRESHAL (TB/TV)				A	Q				A	7) Instrument Characterisation during TB/TV Test

System Level Verification Summary

## ERS-1 A I T SUMMARY BARCHART

STATUS : 14 NOV 90

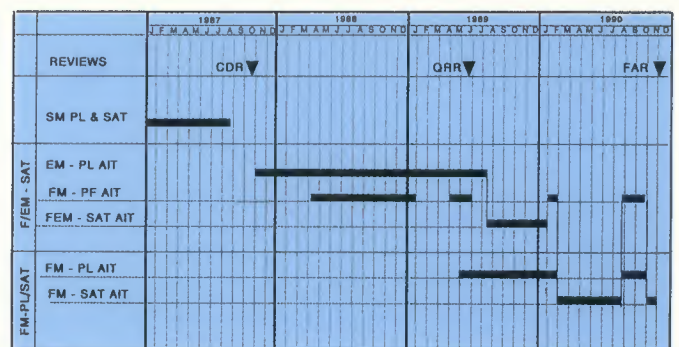

## ERS-1 F/EM SAT AIV PROGRAMME

PREP: W. PLATZER

DATE: 14 NOV 90

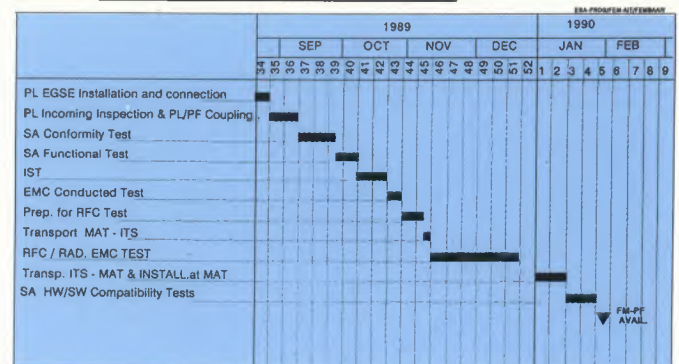

# ERS-1 DATA BOOK

## PREPARATION FOR THE RECEIPT AND USE OF ERS-1 DATA

There is a very wide-ranging user community which will require an equally well-scoped series of products.

From the end-product point of view, the ERS-1 mission is pre-operational in nature, and is therefore expected to demonstrate the ability of satellite remote-sensing systems to provide valuable Earth-observation data from space platforms to many categories of user, ranging from the real-time operators involved in meteorological, oceanographic and environmental applications, to long-term research groups working offline.

The ERS-1 system is also intended to demonstrate some commercial capabilities of the Earth Observation Programme; a part of the operational costs could be covered by funds recovered by commercialising certain ERS products and by affording direct access to the satellite telemetry.

### The ERS Ground Segment concept

The ERS Ground Segment, being the facilities through which the satellite data and the derived products are acquired, processed, distributed and archived, is based on a balance between centralised and distributed facilities.

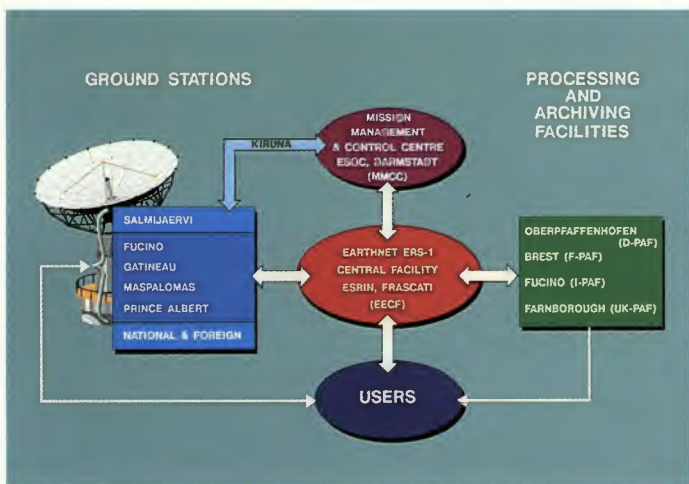

By this system it is hoped to make the best use of resources, while at the same time putting at the disposal of the ERS Programme the relevant expertise already available within the participating countries.

The existing responsibilities of the various ESA Establishments has influenced the sharing of the various ERS ground segment tasks. As a result satellite planning and control functions, including the remote control of the Salmijaervi (Kiruna) station, are the responsibility of the Mission Management and Control Centre at the European

Space Operations Centre (ESOC), in Darmstadt, Germany. Similarly, the user-interface and payload-data-exploitation functions have been implemented within the ERS Central Facility at ESRIN, in Frascati Italy, by the Earthnet Programme Office.

In devising the ground segment, full account had to be taken of a number of technical constraints. For instance, the characteristics of the ERS Space Segment as a multi-sensor payload in quasi-polar Sun-synchronous orbit imposed the need for a network of ground stations, so that onboard-recorded data from the low-rate Scatterometer, Radar-Altimeter and Along-Track Scanning Radiometer can be 'dumped' to ground every orbit before they are overwritten by the next orbit's data. This system is particularly needed for the acquisition around the world of high-rate Synthetic-Aperture Radar (SAR) data, for which only direct readout is possible.

User have placed specific requests for products which call for ad-hoc processing tools at the ground stations operated by or for ESA, and of fast-delivery services to furnish the user centres quickly with selected data products – specifically geophysical products on a global scale for timely assimilation into forecasting models, and SAR images to allow the monitoring of shipping, oil spills, etc.

The preparation for the receipt and use of the ERS-1 data, has largely consisted in designing, setting up new or adapting existing elements of the ground segment, testing and verifying the system from receipt of data through the processing, and distribution phases.

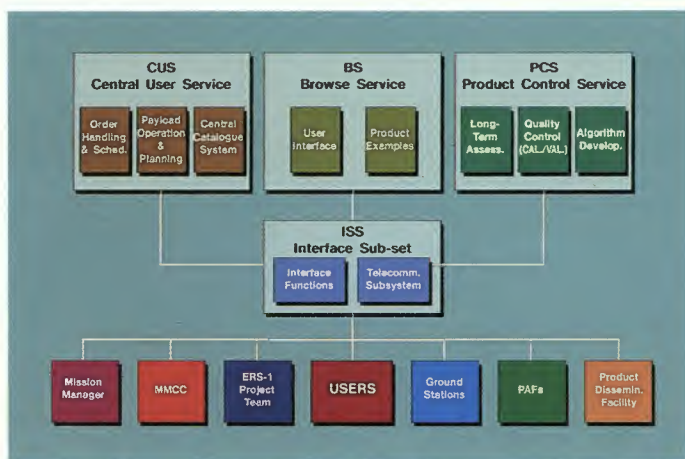

# ERS-1 DATA BOOK

## LAUNCH AND EARLY ORBIT PHASE (LEOP)

The Launch and Early Orbit Phase (LEOP), although short, is extremely critical. There is also a most unusual manoeuvre which as far as is known will be performed for the first time.

### The Orbit to be achieved

To carry out its planned missions, ERS-1 needs to be placed into a Sun-synchronous polar orbit, highly inclined to the equator, giving the satellite visibility of all areas of the Earth as the planet rotates beneath the satellite's orbit. The inclination will be such that the precession of the orbit, caused by the non-spherical components of the Earth's gravity field, will exactly oppose the annual revolution of the Earth around the Sun. Consequently, the orbital plane will always maintain its position relative to the Sun, crossing the equator with the descending node at about 10:30 am local time.

The constant illumination conditions throughout the year that this will provide are advantageous for the ATSR. It also has benefits for the satellite design, in that, for example, the solar array only needs to rotate about one axis, normal to the plane of the orbit, in order to maintain its correct alignment with the Sun.

The orbital inclination required to achieve Sun-synchronism is a weak function of satellite altitude. For ERS-1's mean altitude of approximately 780 km, it needs to be about 98.5°, making it a so-called 'retrograde' orbit. In practice, ERS-1 will be able to change its altitude by a few kilometres, allowing the pattern of its orbital tracks over the Earth's surface to be made to repeat itself exactly after a certain number of days. The three orbital patterns that are planned will have repeat periods of three days, 35 days and 176 days. Each individual orbit in the pattern will last approximately 100 minutes.

### Unusual Manoeuvre

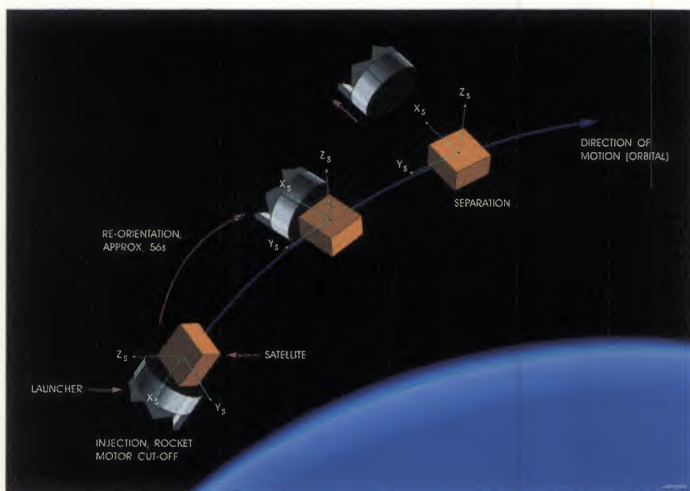

Before separation of the satellite from the third stage of the launcher, the ensemble is turned and re-orientated ninety degrees to the trajectory. By this means, when separation takes place, ERS-1 is left still in the correct orbit, but oriented into its correct flight attitude (flying 'sideways' in relation to the launch direction). After this, the launcher rotates still further, and the four microsattellites can then be released from the third stage without disturbing ERS-1. This re-orientation phase takes approximately 56 seconds.

During the first 173 seconds after separation the attitude control system is not active and the satellite is in free drift, during which it rotates at 0.25° a second about each axis.

### Deployment of spacecraft units

Several spacecraft units will be deployed during the first few orbits after ERS-1's separation from the launch vehicle, while it is still in the LEOP. The scope and method of the deployments is discussed in some detail on page 10.

It is of interest to note the constraints that had to be observed in designing these deployments and their sequencing.

- *Power:* During the LEOP, the battery depth-of-discharge must not exceed 60%. Before solar-array deployment, the spacecraft has to rely entirely on its batteries, which would be 60% discharged after three orbits. Once the solar array is deployed, but not yet rotating, a short battery-charging cycle will be possible, thereby raising their operating limit to twenty orbits.
- *Dynamic:* The sequence of deployments is driven primarily by the results of a shock analysis, which showed that the SAR antenna could be deployed with the solar array already out, but the array drive mechanism had to be locked. This also applies to the Scatterometer antennas, but they could also be deployed after the drive-mechanism release if need be.
- *Timing:* The SAR and Scatterometer antennas must be deployed after the AOCS fine-pointing mode has been achieved, which is at most 2000 s after separation. The SAR deployment should take 18 min, and the Scatterometer antennas 8.5 min each.
- *Visibility:* As much as possible of the critical deployment phases must take place in visibility of one of the seven ground stations participating in the LEOP.
- *Thermal:* The payload elements must be maintained within their survival temperature limits, despite the need to use as little power as possible.

## ERS-1 DATA BOOK

The scope and size of the deployment can be judged by the following sequence of events that occur during LEOP in quick succession:

- deployment of the second S-band antenna
- deployment of the ATSR-payload antenna
- deployment of the solar-array arm
- attitude stabilisation in thruster-controlled Earth-pointing mode
- deployment of the solar-array panels
- deployment of SAR-antenna wings 1 and 2
- deployment of the Wind Scatterometer's fore and aft antennas
- release of the solar-array drive mechanism
- rotation of the solar array
- release of the reaction wheels, via ground command
- entry into wheel-controlled fine-pointing mode, via ground command.

Trajectory measurements will be made at every opportunity during station coverage, so that the spacecraft's orbit can be reliably determined. On the basis of the latest determination, new ground station antenna-pointing data will be sent to all stations to ensure optimum acquisition of the satellite's signals when it appears over the horizon.

### Ground Stations

As can be seen from the illustration below, not only are seven ground stations active during the LEOP, but they cover a world-wide north-south and east-west ambit. They provide good coverage during the first two orbits. This is perfect for the nominal case; however should there be problems, the coverage will degrade as the orbit pattern shifts westwards (or more properly, the Earth rotates eastwards under the orbit). In later orbits the major coverage is from Fairbanks, Alaska, and later still the satellite is visible from Kiruna too.

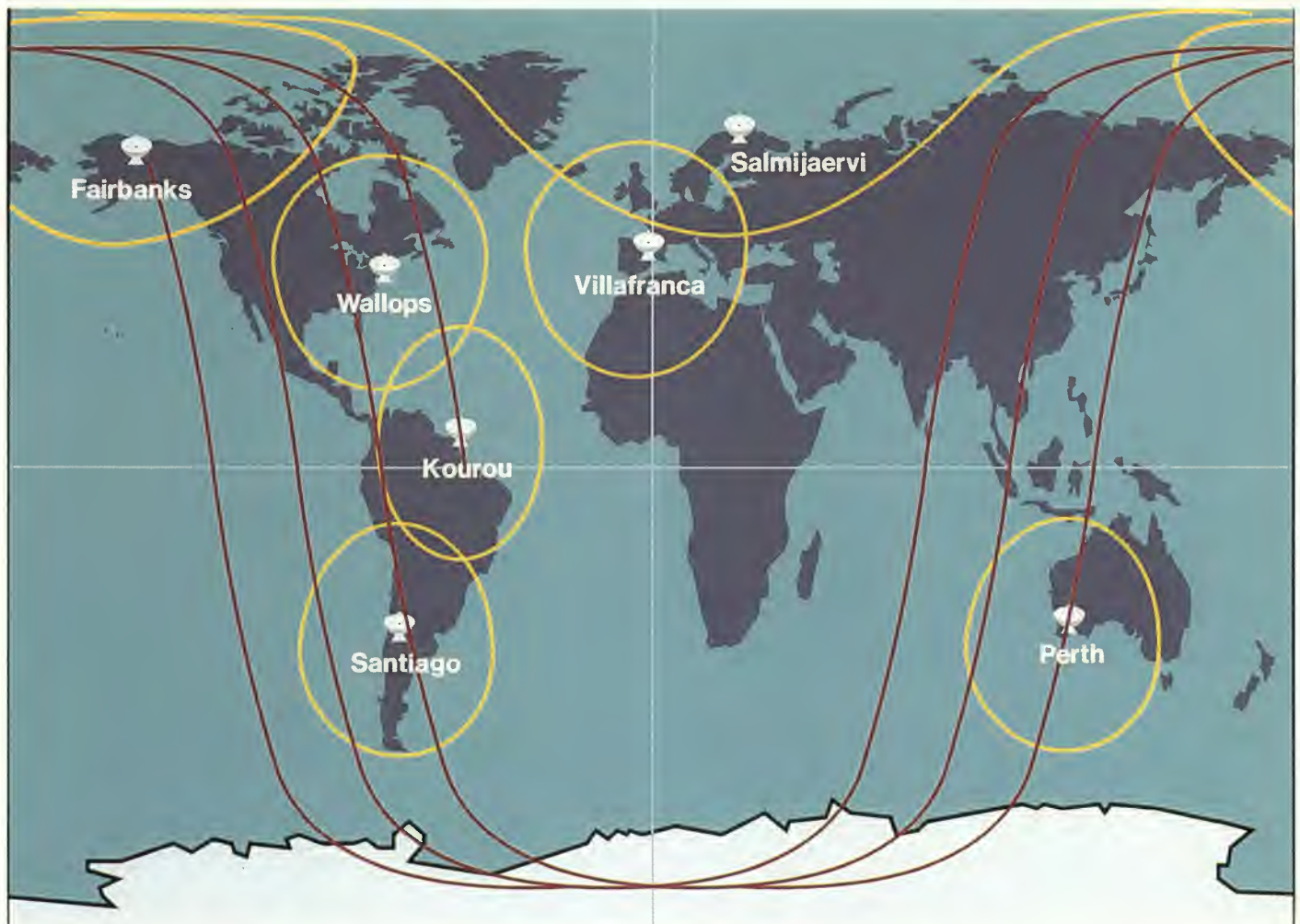

The seven ground stations to be used during the Launch and Early Orbit Phase (LEOP).

# ERS-1 DATA BOOK

## DEPLOYMENT METHOD

All of the deployments which take place during the LEOP will be controlled by the On-board Computer (OBC). Some of the deployments are carried out by means of a pyrotechnic activation sequence triggered by the separation from the launcher, and some are performed using time-tagged macrocommands.

These macrocommands will be loaded into the OBC before launch and the time of execution will therefore be independent of the actual time of launch, during the 4 min window.

To maintain synchronisation between these two types of deployment, the macrocommand queue can be updated very shortly after separation from the launcher, when ERS-1 will be visible from the Wallops ground station, on the east coast of the United States. There will also be a possibility of updating from Fairbanks, in Alaska, or Perth, in Australia.

The S-band telemetry (S2) and ATSR microwave antennas will be released by pyros 5 s and 8 s after separation, respectively. Spring drives will then rotate them into their latched positions in just a few seconds. Next the solar-array arm's deployment will begin with a pyro-release firing, less than a minute after separation. The further deployment requires no additional commands, being mechanically sequenced and driven by spring forces.

Deployment of the solar-array panels themselves will not start until about 45 minutes after separation, when ERS-1 will be visible from Perth. The deployment will again be passive, with the two panels being pulled out of their container by spring-driven pantographs.

The SAR-antenna deployment will start 75 minutes after separation, when the satellite is visible from the Santiago de Chile ground station. The two antenna wings each have spring-driven and motor-driven phases and the whole sequence will be initiated by firing a pyro to release six lever clamps holding the folded antenna in launch configuration.

The Scatterometer antennas will be deployed immediately after the SAR antenna. They are stowed at the sides of the PEM for launch, and the six hold-down points will be released by individual pyro firing. Each antenna deployment involves a single motor-driven rotational movement.

Finally, after  $2\frac{1}{4}$  hours and  $1\frac{1}{4}$  orbits, when the Sun is directly overhead, the solar array will be rotated into position.

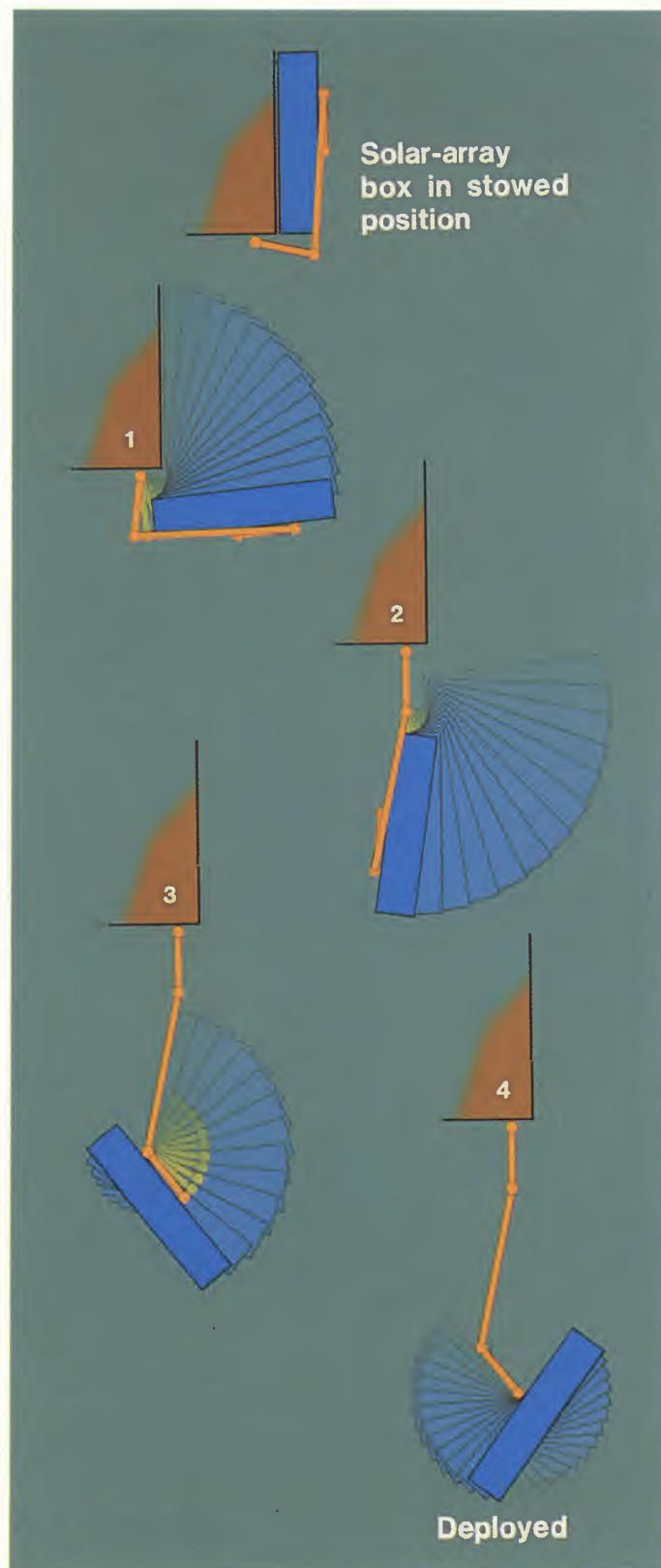

*Deployment sequence of the solar array arm*

# ERS-1 DATA BOOK

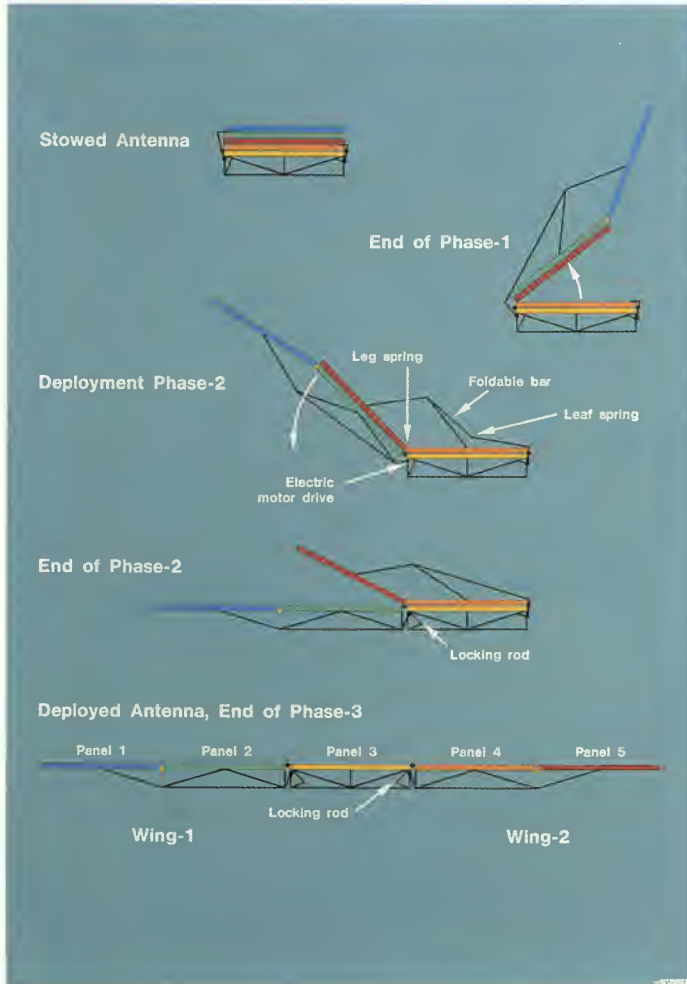

Nominal operational sequence for the Launch and Early Orbit Phase (LEOP)

Above: deployment sequence of the SAR antenna; below during testing, showing rear structure and support struts

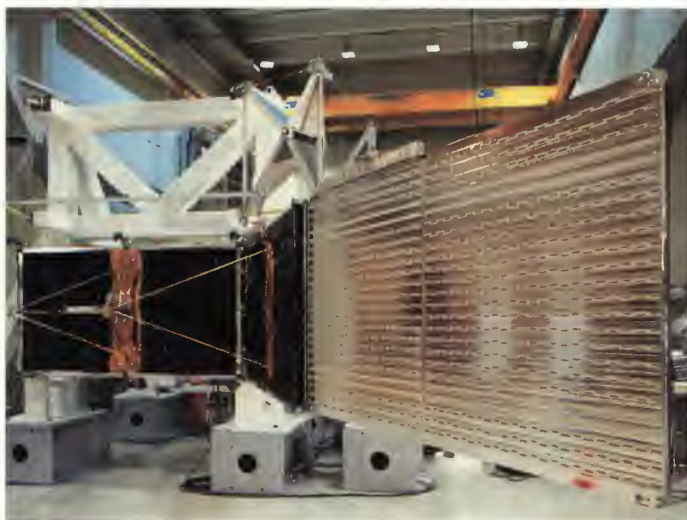

One of the spring drives by which the solar-array arm is deployed



---

# ERS – 1 DATA BOOK

---

## **SPECIAL TECHNOLOGIES AND TEST EQUIPMENT DEVELOPED FOR THE ERS-1 RADARS**

### **(The active microwave instrumentation and the radar altimeter)**

Every satellite represents a challenge for the engineers working on the project, but some of the problem faced during the development of onboard hardware for ERS-1, and also during the ground-based testing of the spaceborne radar, merit being recorded.

#### *SAR (Synthetic Aperture Radar) antenna*

This antenna is 10 m long and 1 m wide. To fit under the launcher's shroud, it had to be folded (5 panels and 4 hinges). To withstand the launcher-induced vibrations, a substantial 'hold-down' mechanism had to be devised to hold down the folded panels. This mechanism was fitted with a pyrotechnic cable cutter operated release mechanism. Springs and motors are then used to deploy the antenna panels into their final configuration.

The planar specifications for the surface of the antenna when deployed were particularly critical, bearing in mind the considerable range of temperatures that the antenna is expected to meet in orbit. Carbon fibre reinforced plastics, with internal metallisation for the electrical functions, were chosen as the basic materials for the waveguides; their advantages also included mass reduction properties. As a result, the surface of the deployed antenna is a plane within better than 1.5 millimetres: a very good achievement under vacuum conditions and under varying thermal conditions.

To carry out far field tests on such a big antenna on the ground, test ranges several kilometres in length would have been needed. Therefore near field test techniques were developed, based on a highly accurate near field scanner. The far field performance was then deduced on the basis of a mathematical model.

#### *The Active Microwave Instrumentation (AMI) high power amplifier*

A new range of peak power had to be explored: 5 kilowatts during pulse duration of 27 to 130 microseconds, with the correspondingly high voltages in the power supplies.

The amplifier's high power consumption called for high efficiency. To avoid wasting the beam's DC power, the travelling wave tube power amplifiers were designed so that they switch the electron beam off during the interpulse period when no interaction between the beam and the high frequency (microwave) field occurs.

The high peak powers of the radars may cause 'multipaction', an electron avalanche effect in vacuum, which may subsequently cause physical damage and performance

degradation. All high power elements were therefore designed with this constraint in mind, and elaborate test programmes demonstrated that there was a sufficient multipaction margin.

The high voltages, some 15 kV, could cause arcing in a non-perfect vacuum, and special attention was paid to the provision of adequate venting in all elements carrying high voltages under vacuum conditions to minimise the risk of residual gas pressures. A series of life tests gave confidence that the high power amplifier's three years life expectancy could be achieved without degradation of performance.

#### *Pulse compression chirp generators*

For a radar with unmodulated carrier, the higher the peak power and the shorter the pulse, the better the resolution. For a given resolution, modulating (chirping) the signal results in a reduction in the peak power, but makes the pulse longer while keeping the same pulse energy. With the reduced peak power (5 kW for the synthetic aperture radar, 50 W for the radar altimeter) it is easier to handle the multipaction problem. The lower peak power limit is imposed by the maximum chirp lengths that can be achieved with existing (surface acoustic device = SAW) technology as well as by timing considerations. The reduced peak power can, at the same time, be generated with reduced voltages in the travelling wave tube's power supplies, thus lowering the risk of arcing.

The chirp generators and the delay lines in the RA have to be highly linear and very stable. The Lithium-Niobate technology used is state-of-the-art. The real challenge lay in the mounting and packaging of the large (8cmx1cmx1mm) crystals in an hermetically sealed box that protects them from the ground, the launch and the space environment. That was not all; the packaging also had to provide good thermal isolation (0.2° variation for an external variation of 65°).

#### *Ground testing and calibration*

Spaceborne radars, whether used for measuring wind-fields, creating SAR images or carrying out radar altimetry over the sea or land, are initially specified in geophysical terms and take advantage of the homogeneous movement of the satellite.

The geophysical parameters (such as wind speeds) have to be translated into engineering parameters (such as decibels). Careful absolute and relative calibration has also to be introduced since wind measurements in particular are based on the knowledge of the absolute magnitude of the radar backscatter.

The radar altimeter's return signal simulator (RSS) is a state-of-the-art piece of test equipment: a device which upon

---

## ERS – 1 DATA BOOK

---

receipt of a RA chirped transmit pulse, gives an echo which is delayed appropriately for the pulse's round trip time from the satellite to the Earth and back. The chirped pulse is modulated by variable frequency, and variable amplitude tones in the RSS to simulate ocean and ice reflection characteristics. Since the radar altimeter is designed to measure round trip times of about 5 microseconds, with some hundreds of picosecond precision, the return simulator contained a highly temperature-stabilised delay line.

### *Conclusion*

Space radar technology was developed for the first time in Europe. It took more than 10 years for the more complicated equipment to be fully space qualified. The technology is state-of-the-art and can form a solid basis for future developments. It is the intention, for example, that the development of the radar transmitter for the Canadian Radarsat spacecraft should be based on the radar transmitter on the ERS-1 high power amplifier. The near field planar scanning method will also be used for its antenna measurements. Radar altimeter technology for a second generation RA to be flown on the European Polar Platform in 1997 is largely based on the technologies and equipment developed and qualified for ERS-1.

---

## ERS - 1 DATA BOOK

---



*The ERS-1 spacecraft in launch configuration, the arrays and antennas folded, during tests at the European Space Agency's ESTEC facilities, in Noordwijk, The Netherlands*

## STRUCTURE

### The Payload Module

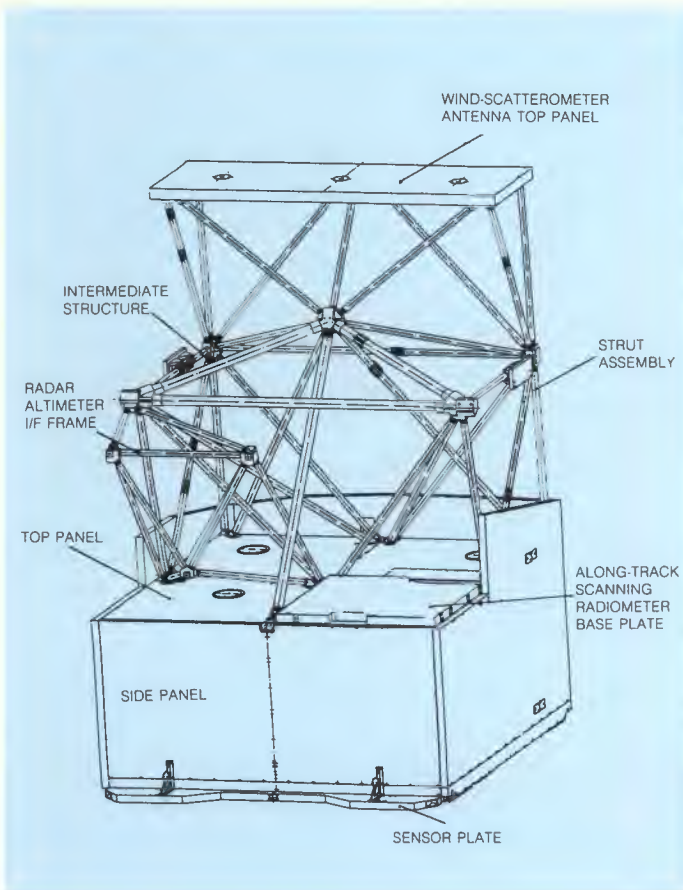

The ERS-1 payload support structure showing the boxlike Payload Electronics Module (PEM) structure and the complex strut assembly of the Antenna Support Structure (ASS)

The mechanical structure of the payload has to meet a number of challenging requirements, including tight mechanical-stability and thermal-isolation constraints. It was also foreseen that the payload would need to be disassembled many times, and this had to be considered in its basic design. There are two main parts to the payload module, the Payload Electronics Module (PEM) and the Antenna Support Structure (ASS), for which different design solutions were adopted.

The PEM is an aluminium face-sheet/honeycomb structure supported by nine internal vertical titanium beams (titanium was selected for its low thermal conductivity and expansion coefficient). The central beam lies at the intersection of two internal cross-walls, so that the PEM is effectively divided into four separate compartments. Each outer panel is dedicated to a particular instrument, to simplify integration

logistics, and is fixed to the vertical beams by close-tolerance bushes and titanium screws. This construction minimises settling effects due to vibration and ensures that the necessity of having to assemble the PEM several times did not result in structural problems.

The payload is separated from the platform by a non-load-bearing electromagnetic (EMC) shield. An aluminium-honeycomb panel closes the opposite end of the structure, stabilising the beams and providing the interface to the ASS at the beam locations. These provide a load path from the ASS to the platform.

It was clear that the integration programme would involve many separations between the PEM and the platform and to meet this demand, a system of tapered dowels and shims was developed. To facilitate connecting and disconnecting the instrument panels to and from the main harness, there are large connector brackets attached to the lower parts of the panels, with simple covers.

The ASS, requiring structural stiffness whilst minimising thermal distortion, has been manufactured primarily from high-modulus carbon-fibre-reinforced plastic (CFRP) tubes, with titanium being used for all the highly loaded structural elements such as nodes, strut end-fittings, and interface brackets.



Part of the Antenna Support Structure (ASS) with the antennas removed

---

# ERS-1 DATA BOOK

---

The lower part of the assembly consists of five tripods, three of which provide support points for the SAR antenna and two intermediate support points for the upper assembly. These tripods are also connected to each adjacent node.

The CFRP sandwich plate at the top, which carries the Scatterometer antennas, is supported by three further tripods attached to the intermediate points and the SAR central point. The Altimeter's antenna is attached at three node points by a triangulated strut system.

This intricate, highly stable assembly was challenging in terms of design, manufacture and integration. This is amply illustrated by the central titanium node, which interfaces to ten high-tolerance struts without inducing built-in stresses.

## **The Platform Structure**

The platform module is derived from that developed for the French national Spot programme. The overall structure consists of a service module, a propulsion module, a solar array sub-assembly and the payload platform previously described. The structure is a rigid framework, with the loadings of the payload being transmitted directly through the central tube by means of metal struts. Materials such as carbon fibre and titanium were chosen for their low expansion coefficient.

### *The Service Module*

The service module, built around a central tube, holds all the 'housekeeping' subsystems, supports the propulsion module, and the payload. It also makes the interface with the upper stage of the launcher through the lower part of the tube. It also houses the battery module containing four 24 AH batteries; an arrangement which allows the module to radiate to space while grouping all the cells in the same place, thereby reducing internal thermal gradients.

The central tube structure makes the connection between the launcher and the payload. Around it are three 'wings' carrying subsystem components, while other subsystems are housed on an upper and lower platform, and on semi-partition structures.

The service module also has interfaces with the solar generator, and the battery compartment, as well as the launcher and propulsion module.

The cage-like structure is made of honeycomb 'sandwich plate' aluminium alloys, and the central tube is welded with aluminium alloys. The central tube is rigidly constructed and reinforced by four longerons. The general thickness of the tube material is 4 mm, reduced in certain areas by chemical means to 2.6 mm. The type of 'mecano-welding' used ensures a very rigid structure, and suppresses to a minimum the extensibility of the interfaces.

### *The Propulsion Module*

The propulsion module carries the propulsion units of the Attitude and Orbital Control Sub-System (AOCS). There are four hydrazine tanks and a set of thrusters. The hydrazine tanks are fitted to the platform, and the module has a trellis structure to support the various AOCS, and other interface connections and cabling. The trellis is rigid, being constructed of aluminium, carbon fibre and titanium.

The propulsion module supports the payload at nine points by means of an interface frame.

### *The Solar Array Sub-Assembly*

The solar array sub-assembly is of the fold-out type, supplying power greater than 2000 W from its silicon solar cells. In the folded, undeployed, position it is stowed in a rectangular box on the +Z face of the platform (sky-pointing). When deployed it is rotated at the orbital velocity around the +X (pitch) axis.

# ERS-1 DATA BOOK

## POWER SUPPLY

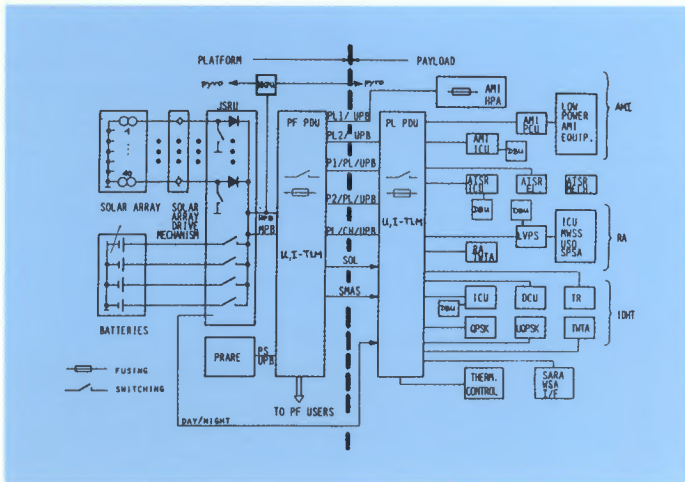

Electrical Power Distribution Block Diagram

The two main blocks of the satellite power supply as shown in the diagram are the platform with its battery compartment, solar generator, shunt regulator and main power distribution unit (PDU) which feeds and fuses the platform users and the payload as a whole, and the payload 'block' with its payload power distribution unit.

The payload receives its power from the platform PDU on five lines, and distributes them to the instruments through:

- one regulated power bus (50 V) which supplies the payload PDU internal couplers carrying all communications between the payload PDU and the on-board data handling system (OBDH).
- one unregulated permanent bus distributing permanent power to the Along Track Scanning Radiometer (ATSR), the 20 V regulator for internal electronics of the payload PDU, the SAR and wind motors power supply, and the antennas' microswitches.
- two unregulated power buses which supplies the low level heaters.
- one unregulated high power bus which supplies payload electronics, instrument control units, high level heaters, and the Active Microwave Instrument (AMI) antenna heater.
- one unregulated high power bus which supplies the AMI high power amplifier (HPA).

### Electrical Sources

**Batteries.** The battery parameters are:

- Four batteries with 24 cells
- cell type: V024S
- cell capacity: 24 AH
- cell voltage range: 1.04 ... 1.6 V
- cell internal impedance: ~ 4 mOhm

### Solar Generator.

The solar array consists of 10 electrical sections equipped with BSFR (Back Surface and Field Reflector) solar cells. The solar array is connected to the electrical power supply subsystem by the solar array drive mechanism which points the array continuously towards the Sun.

### Electrical Distribution

The subsystems within the platform and the payload are interconnected electrically by harnesses. The platform carries its own harness which provides an electrical access for the payload via two sets of interface connectors. The payload receives power from the set of unregulated lines and one regulated line, and communicates with the on-board computer via the connectors.

## PYROTECHNICS

The ERS-1 pyrotechnics concept is mainly determined by the platform pyro-circuit design. The firing of the pyro devices will be performed by the housekeeping and pyro unit. ERS-1 will use 16 pyrofunctions: eight for the platform and eight for the payload antenna deployments.

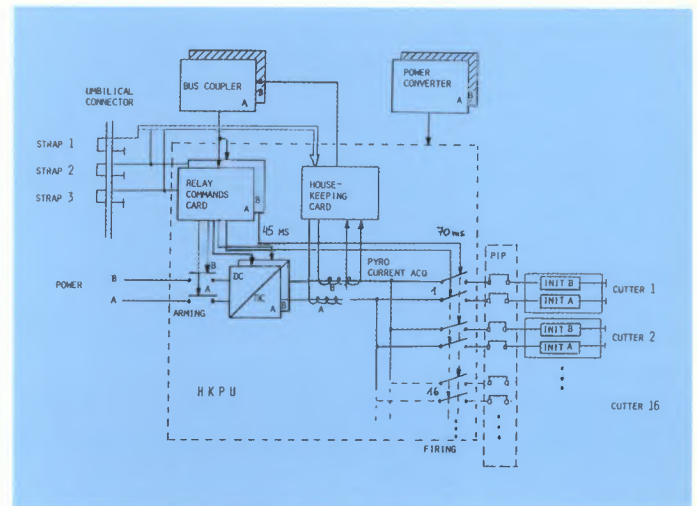

Pyrotechnics block diagram

Two types of pyrotechnics are used for all deblocking and release mechanisms:

- cable cutters AMD-BA 7 CCD 15 W for all the platform functions and the ATSR antenna, and
- bolt cutters AMD-BA 7CC 60 DPWH3 for the SAR and Wind Scatterometer antennas.

For safety reasons the pyrotechnics software can only be started if the software reads twice consecutively that at least two of three initialisation straps (shorting plugs in the umbilical connector between satellite and Ariane adaptor which will open after separation), are activated.

---

## ERS-1 DATA BOOK

---

### ATTITUDE AND ORBITAL CONTROL

To carry out its mission ERS-1 must be so positioned in its orbit that the instruments in its payload can all scan along the predetermined paths designed to give the most complete coverage possible during a set number of orbits. To achieve this, ERS-1 is a three-axis-stabilised, Earth-pointing satellite.

Its yaw axis will be pointed towards the local vertical with respect to a reference ellipsoid, taking the Earth's oblate shape into account. The direction of the pitch axis will be oscillated slightly during each orbit to keep its orientation normal to the composite ground velocity vector, taking account of the Earth's rotation. This is specifically to assist the operation of the Active Microwave Instrument.

The residual attitude errors (after static-error removal by appropriate biasing of the attitude-control system) are expected to be no more than  $0.06^\circ$  on pitch,  $0.07^\circ$  on roll, and 0.085 on yaw.

ERS-1 has a range of attitude sensors. The long-term reference in pitch and roll is obtained from an infrared Earth sensor. The yaw reference will be obtained once each orbit from a narrow-field Sun sensor which is aligned to view the Sun when the satellite is at a particular point in its orbit. Each sensor has a back-up in cold redundancy. The short term attitude and rate reference will be obtained from three gyroscopes selected from a pack of six. In nominal operations only three gyroscopes are on, the remaining three (each of which can be used to replace a failed gyroscope) are kept in cold redundancy. Finally, there are two wide-field Sun-acquisition sensors for use in safe mode, when the satellite is Sun- rather than Earth-pointing.

The primary means of attitude control is provided by a set of reaction wheels, which are nominally at rest. They can be spun in either direction, exchanging angular momentum with the satellite in the process. It will also be possible, if there should turn out to be permanent torques on the satellite due, for instance, to radiation pressure on the solar array, to bias one or more wheels to be nominally not at rest, but rotating with a defined speed.

Angular momentum will also need to be dumped from the wheels on a regular basis and a sophisticated system has been devised for this purpose. ERS-1's onboard computer contains a simple model of the Earth's magnetic field, and is also able to control the current in a pair of orthogonal magnetic coils. These coils, called 'magneto-torquers', will generate torques by interacting with the Earth's geomagnetic field. Using a control loop and the built-in field model, the spacecraft's onboard computer will continuously energise the magneto-torquers to keep the wheel speed close to the nominal values.

ERS-1 has a number of monopropellant-type thrusters, aligned about the spacecraft's three primary axes, in which hydrazine dissociates exothermically as it is passed over a hot-platinum catalyst. They will be used in different combinations to maintain and modify the satellite's orbit and to adjust its attitude during non-nominal operations. This will normally be done by using pairs of thrusters to provide in-plane thrust when slightly changing the orbital height or speed, or by turning it in yaw to obtain out-of-plane thrust when slightly modifying the orbital inclination.



*The thrusters on the flight model of ERS-1*

---

## ERS-1 DATA BOOK

---

### THERMAL CONTROL



*An overall impression of the thermal control system*

The ERS-1 thermal-control system is basically passive, complemented by an active heater system. The thermal-control approach follows the modular overall design of the satellite, whereby the payload, platform and battery compartment are thermally insulated from one another as far as practicable, allowing separate analysis and testing. The individual modules are also insulated from the external environment by multi-layer insulation blankets, except for the radiators.

The latter are covered mainly with materials which absorb only a low level of solar radiation, and have a high infrared emittance, in order to reject efficiently the internally dissipated energy. These radiator areas have been optimised for the extreme hot and cold operating conditions that will be encountered in nominal Earth-pointing attitude, and during the Sun-pointing safe mode in which the payload would be inert.

A heat pipe is used to transfer heat from the ATSR cooler to one of the radiators.

High heat fluxes in the payload electronics module are spread over larger areas by local skin thickening of honeycomb side panels or by constant-conductance heat pipes embedded in these panels.

Heater systems, which are fully redundant during nominal operations and partially redundant in safe mode, provide autonomous active thermal control in the difference satellite areas. The heater systems themselves will be controlled predominantly by onboard software in nominal modes and by thermostats in safe mode, or in failure cases when the onboard computer is not available.

An anomaly-management system is triggered by failures in the heater systems and/or out-of-range equipment temperatures. It decides on the appropriate corrective action, which can be to switch to redundant heater branches and/or to switch off the payload.

All software parameters used for control or surveillance can be enabled, inhibited or updated by ground command, providing a high degree of flexibility for coping with a variety of unforeseen events or conditions.

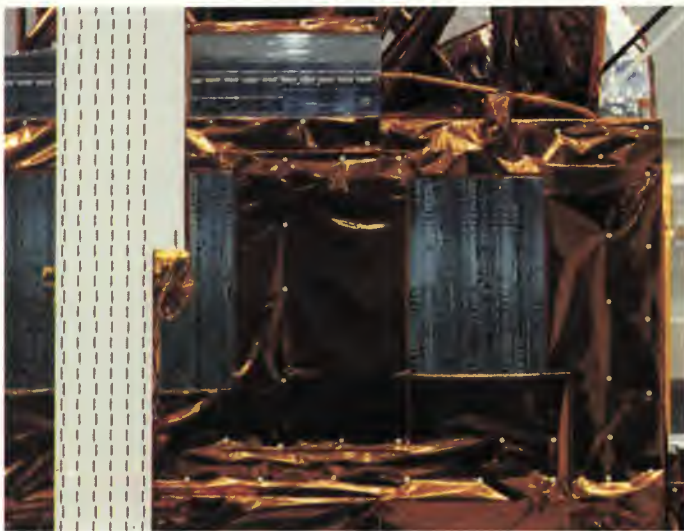

*The radiators and the heat pipe (the thin pipe horizontal to the top of the platform)*



---

## ERS-1 DATA BOOK

---

### ON-BOARD DATA HANDLING AND TELEMETRY

ERS-1 carries a significant number of software packages run by different processors spread throughout the platform and the payload.

In the platform, the *On-Board Computer (OBC)* runs the so-called 'Centralised Flight Software', which is a small software package (44 kwords) incorporating all the basic functions needed to conduct the mission in an optimal fashion. In addition, each payload element (AMI, RA, ATSR and IDHT) contains its own decentralised 'Instrument Control Unit' (ICU).

These five computers are linked by the *On-Board Data-Handling (OBDH)* bus, and communicate with each other via a high-level packetised protocol. The PRARE, as a platform passenger, is not a user of the OBDH bus.

This set of interdependent computers fulfils a critical requirement. ERS-1 is an extremely complex satellite, with a great many modes, parameters and logical conditions to be set and respected throughout each orbit. It is required to have 24 h autonomy, and this could only be achieved by providing intelligent payload elements controlled by a capable central computer. A basic concept in this philosophy is the 'macrocommand', a coded instruction expanded and acted upon by the ICU. In this way the ICU relieves the OBC of many detailed tasks related to internal instrument configuration and operations.

It has been a primary requirement that all of the onboard processors can be reprogrammed in flight, and many of the operating characteristics are controlled by tables of variable parameters. Commands are provided for manipulation of these tables so that major changes can easily be made in the operating characteristics.

The main functions of the OBC flight software are:

- to take the spacecraft from launch to operational configuration, by automatically sequencing such events as the firing of pyrotechnic cable-cutters and unfolding antennas;
- to manage the spacecraft in orbit, operating the platform subsystems and managing the overall payload. This includes overall power regulation, power distribution and thermal control of the platform subsystems, the PEM and the antennas. The Attitude and Orbit Control System (AOCS) will also be piloted by the OBC flight software;
- to monitor the spacecraft, in order to detect and neutralise any critical failure and thereby preserve the mission. In the case of serious failure, the flight software will autonomously reconfigure the faulty platform subsystem to the redundant hardware, or switch-down any payload instrument that shows anomalous behaviour. Should the reconfiguration fail, the spacecraft will be put

into a so-called 'safe mode', in which the payload will be switched off, the solar array parked in the canonical position, and the satellite placed in a Sun-pointing attitude, awaiting further intervention from the ground;

- to allow mission pre-programming from the ground. The OBC flight software can memorise up to 16 orbits' worth of macrocommands for scheduled transmission to the various payload instruments, usually when the satellite is out of ground coverage. This mechanism can also be used to achieve temporary attitude (e.g. roll-tilt) effects;
- to report to the ground. Every second, the S-band telemetry link will transmit 256 bytes of data obtained by the OBC flight software, either on the real-time status of the platform and payload, or from dedicated memory areas where the significant event history has been recorded. The flight software can also support troubleshooting via S-band telemetry, in that it is able to access and transmit the contents of all the computer memories onboard the satellite.

The ICUs run software packages the function of which depends on the particular instrument that they serve, but there is some commonality. The common ICU tasks are:

- interfacing between the OBDH bus and the instrument hardware, receiving macrocommands and providing packetised telemetry, so-called 'ICU Formats';
- executing macrocommands, by putting the instrument into the appropriate mode to perform commands sent from the ground;
- monitoring sensors within the instruments in order to detect any critical failure, and if necessary switching the instrument to 'standby mode';
- reporting to the ground by the telemetry of 'ICU Formats' consisting of real-time data (sensor measurements, science-data samples, software variables, etc.) or data recorded to trace the history of the instrument (mode transitions, anomalies, etc.).

The other functions of the ICUs are related to scientific data conditioning/processing, and are therefore more specific to each instrument. Both the AMI and RA ICUs interface with scientific computers, known as the 'Scatterometer Electronics' and 'Signal-Processor Sub-Assembly' (SPSA), respectively. The AMI ICU manages a large memory buffer which accommodates the data originating from the sampling of the radar echo in SAR and Wave modes, while the IDHT ICU manages the tape recorders.

Two types of time-management functions are carried out onboard; the scheduling of events and the time-stamping of measurements. All timing will be referenced to a clock maintained by the OBC, providing time signals with 4 ms resolution and correlated with UTC (Universal Time Coordinated) by the Kiruna ground station. Events will be scheduled by associating a time with each macrocommand.

# ERS-1 DATA BOOK

The time-stamping of measurements, known as 'datation', will also be performed by the ICUs, which will write the appropriate binary time code, transcribed from the ICU clock, into the secondary header of each source (data) packet.

## Instrument data-handling and telemetry

ERS-1 has two telemetry systems. The platform's needs will be served by a classical Telemetry, Telecommand and Control (TTC) system operating in the S-band. This low-rate (2 kbit/s) system will be used to transmit the ICU formats for housekeeping purposes.

Because of the high bit rates involved, the science data cannot use this link and the payload therefore includes an *Instrument Data Handling and Transmission (IDHT)* system. This will allow real-time transmission of AMI Image-Mode data, providing a regional service to local ground stations and global recording and telemetry of the other sensors.

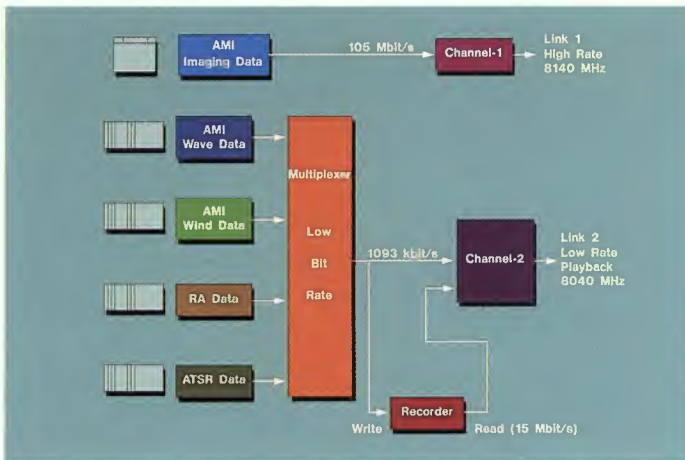

Block diagram of the X-band science data transmission system

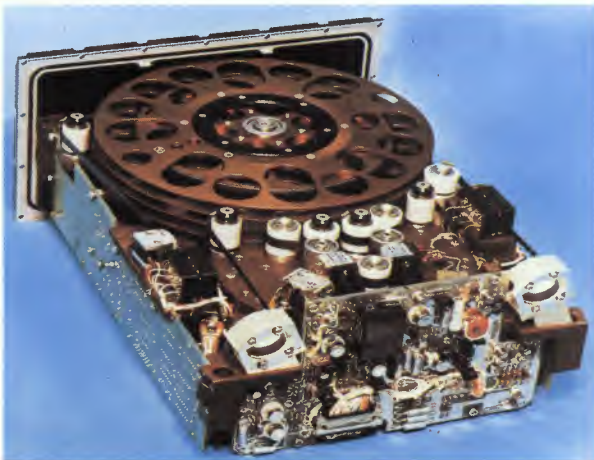

One of the two 6.5 Gbit tape recorders, which holds 3000 ft of 1/4-inch tape

The instruments will generate data in the form of 'source packets', which constitute a logical division of telemetry data from the instrument point of view. However, these will not be the fundamental unit as far as transmission to the ground is concerned, for which a further division into 'transport frames' will be made. To minimise overload there is a physical constraint that a transport frame must not be bigger than the smallest user source packet. To achieve equal data transmission for individual sources, a fixed packet transport sequence is applied in the low rate data multiplexer depending on 'data valid status'. In addition to pieces of source packets, transport frames will contain synchronisation and transmission error-control information. The source-packet structure will then be reassembled from transport frames at the ground stations.

Three data streams will be transmitted from the IDHT. The first will contain the high-rate data from the AMI Image Mode, with auxiliary data and a copy of the S-band telemetry data, at a total rate of 105 Mbit/s. This channel has an X-band link dedicated to it. The other sensors will have their data combined, again with a copy of the S-band data and satellite ephemeris information, into a (comparatively) low-rate data channel, operating at 1.1 Mbit/s, which will be continuously recorded by the onboard tape recorder. This recorder will be replayed at 13.6 times recording speed (in reverse order to save rewind time) when over the ground stations, to form a second data channel, at 15 Mbit/s. It will share the second X-band link with the live transmission of the combined low-rate data, which will constitute the third data stream.

In playback mode the tape recorder will accept external synchronisation clock from the radar altimeter ultra-stable oscillator (USO). By this method the behaviour of the USO can be verified after demodulation.

The tape recorder has been designed to store a full orbit of continuous 1.1 Mbit/s low-rate data on 3000 ft of 1/4-inch magnetic tape, leading to a total data recording capacity of 6.5 Gbit. When performing a data dump to high-latitude ground stations, such as the primary Kiruna station, the spacecraft's solar array might cause a brief occultation of the link, due to the system geometry. On passes when this occurs, the onboard command scheduling will include a stop in playback before the occultation, a slight rewinding of the tape, and a reactivation of playback mode after the occultation.

The data-handling part of the IDHT is followed by the transmission subsystem which modulates data on to two RF carriers for transmission to the ground. A waveguide manifold power combiner multiplexes the two RF signals for transmission to ground via a IDHT shaped beam antenna.

# ERS-1 DATA BOOK

The modulation scheme used for the high-rate channel is quadrature phase-shift keying, called 'QPSK', which allows four distinct states during each clock cycle and makes it possible to transport two bits of information during each cycle. This will reduce the radio-frequency bandwidth required for transmission by a factor of two compared with a simpler modulation scheme. The low-rate link will use unbalanced quadrature phase-shift keying, or 'UQPSK', to modulate the 15 Mbit/s recorder dump and the convolutionally encoded real-time data onto a single link. If there are no recorder dump data, bi-phase-shift keying (BPSK) will be used for the real-time data.

Immediately before and after recorder playback, the link will be automatically switched between BPSK and UQPSK operations, with minimum impact on the real-time data stream. The ERS-1 ground demodulators have been designed to accommodate this mode switching automatically.

The fact that the X-band transmission was required to have a minimum power-level fluctuation during the satellite pass led to the design of a shaped-beam antenna able to compensate for losses at low satellite elevation angles, when the distance to the ground station is long, and the attenuation due to the atmosphere's water content is high. To achieve this, the antenna reflector is shaped so that its radiation pattern compensates for the inverse-square-law variation in received power with distance as the satellite passes across the sky at the ground station. The polarisation of the radiated energy is rotated to compensate for Faraday rotation due to the Earth's ionosphere.

The IDHT is physically located on the Earth-facing panel of the PEM, with the tape recorders mounted inside on one of the cross-walls.

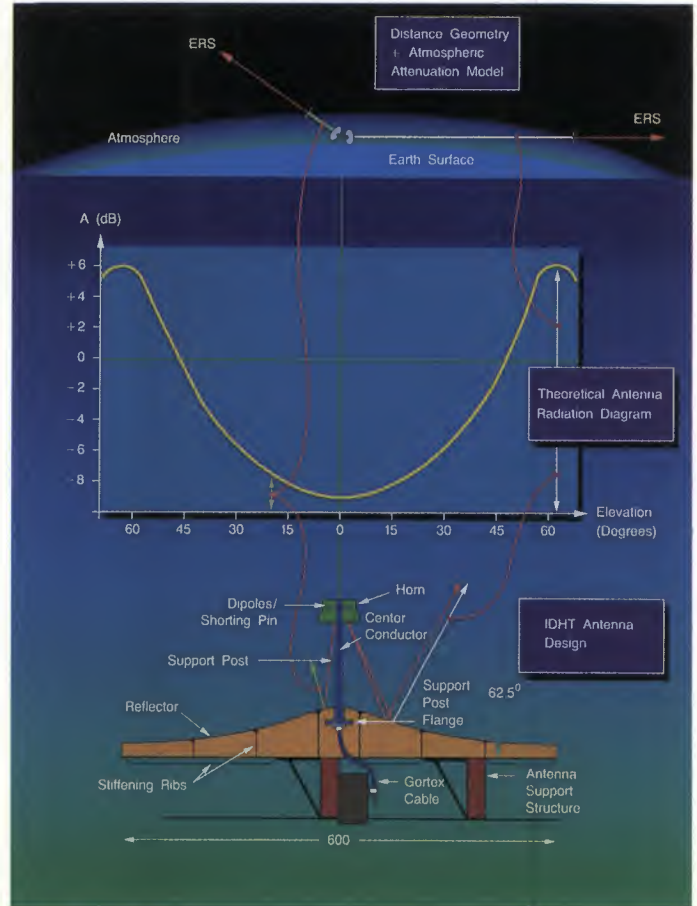

An explanation for the unusual IDHT antenna design

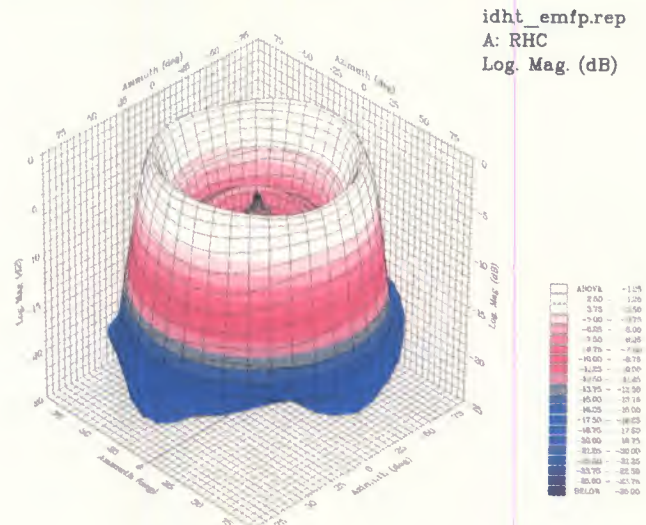

**THE ACTIVE MICROWAVE INSTRUMENT (AMI)**

Two separate radars are incorporated within the AMI, a *Synthetic-Aperture Radar (SAR)* for 'Image and Wave Mode' operation, and a *Scatterometer* for 'Wind Mode' operation. The operational requirements are such that each mode needs to be able to operate independently, but the Wind and Wave Modes are also capable of interleaved operation, in a 'Wind/Wave Mode'.

In *Image Mode*, the SAR will obtain strips of high-resolution imagery 100 km in width to the right of the satellite track. The 10 m long antenna, aligned parallel to the flight track, will direct a narrow radar beam onto the Earth's surface over the swath. Imagery will be built up from the time delay and strength of the return signals, which depend primarily on the roughness and dielectric properties of the surface and its range from the satellite.

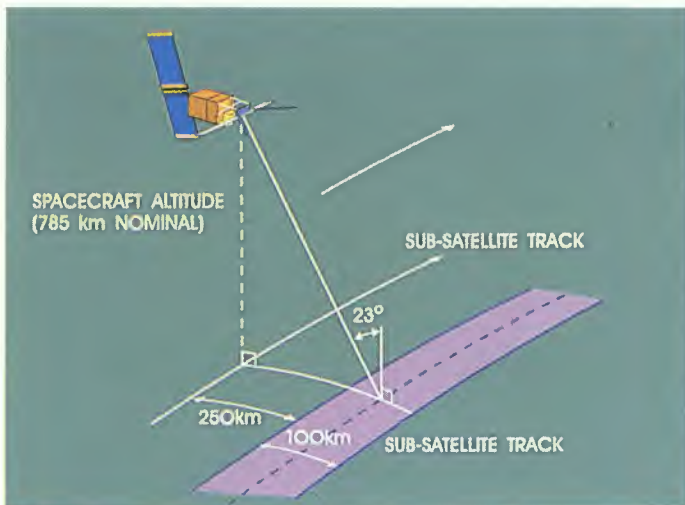

The SAR geometry in the image mode

The SAR's high resolution in the range direction is achieved by phase coding the transmit pulse with a linear chirp, and compressing the echo by matched filtering; range resolution being determined by means of the pulse travel time. Azimuth resolution is achieved by recording the phase as well as the amplitude of the echoes along the flight path. The set of echoes over a flight path of about 800 m will be processed (on the ground) as a single entity, giving an azimuth resolution equivalent to a real aperture 800 m in length. This is the 'synthetic aperture' of the radar.

While operating in the Image Mode the AMI cannot operate its other modes. The power demands during the Image Mode are such that operating time has to be limited to a maximum of 10 minutes during each orbit. The data rate of 100 Mbit/s is far too high for onboard storage, so images will only be acquired within the reception zone of a suitably equipped ground station.

Wave Mode operation of the SAR will provide 5 km x 5 km images at intervals of 200 km along track, which can then be interpreted to provide wave spectra. Because the data rate is relatively low, onboard data storage is possible, and there is a global sampling of wave spectra.

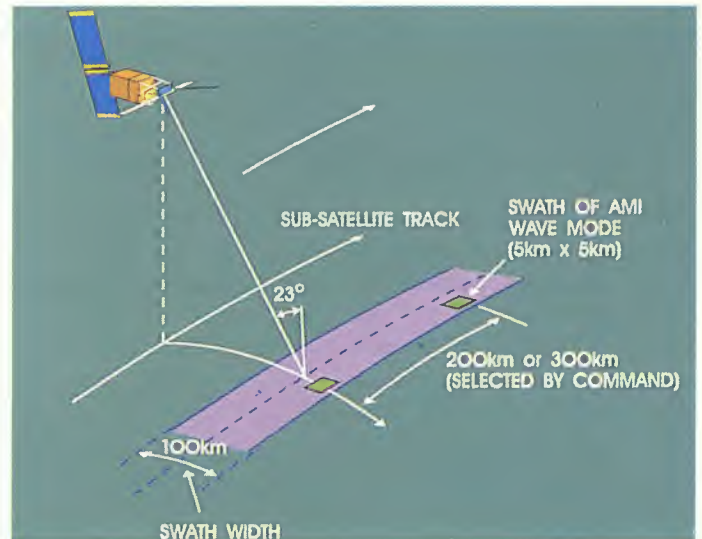

The SAR geometry in the wave mode

The *Wind Mode* will use three antennas to generate radar beams looking 45° forward, sideways, and 45° backwards with respect to the satellite's flight direction. These beams will continuously illuminate a 500 km-wide swath as the satellite moves along its orbit, and each will provide measurements of radar backscatter from the sea surface on a 25 km grid. The result will be three independent backscatter measurements for each grid point, obtained using the three different viewing directions and separated by a short time delay. As the backscatter depends on the wind speed and direction at the ocean surface, it will be possible to calculate the surface wind speed and direction by using these 'triplets' within a mathematical model.

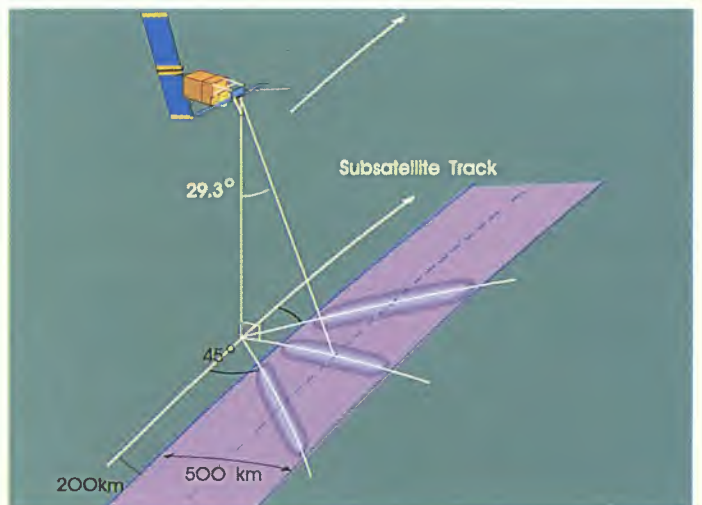

The AMI geometry in the wind mode

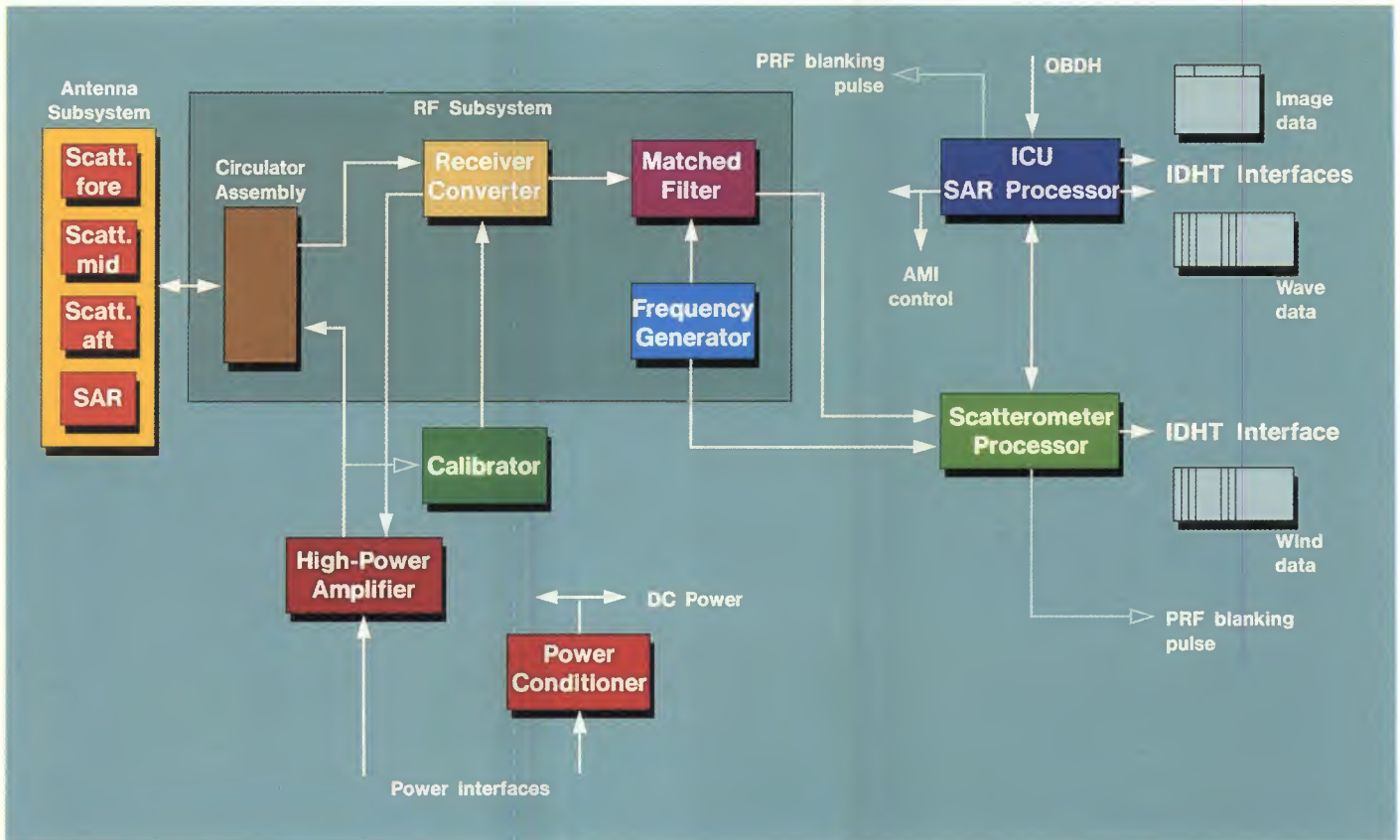

Functional Block Diagram of the Active Microwave Instrument

## The AMI Electronics

The AMI electronics cover two full 2 m x 1 m side panels of the Payload Electronics Module (PEM). In addition, the calibration unit is mounted on one of the cross-walls inside the PEM, the switch matrix and its controller are on the top panel, and the four antennas, one of the most characteristic elements of the ERS-1 satellite, on the Antenna Support Structure (ASS).

The RF-subsystem units, covering half a panel in the spacecraft, contain all the electronics needed to generate the transmit pulses and to amplify and filter the received signals.

The IF Radar contains a transmit and a receive section. The transmit section, in Image Mode, generates a linearly chirped pulse of 15.55 MHz bandwidth and 37.12  $\mu$ s length. This pulse is generated by gating the 123 MHz output of the Frequency Generator into a short pulse and applying it to a dispersive delay line. At the output of the delay line, the pulse is amplified and cut to the correct length of 37.12  $\mu$ s. In Wind Mode, the transmit pulse is generated by the Scatterometer Electronics, and the IF Radar acts only as an amplifier.

The Up- and Down-Converters are contained in a single unit. The upconverter converts the output signals of the IF Radar to 5.3 GHz and amplifies them to a level of about 250 mW, required for the input of the High-Power Amplifier (HPA).

The two redundant units of the HPA occupy one complete panel; each consists of a large power conditioner unit (EPC), a travelling-wave-tube amplifier, an output isolator, and an output filter. The latter two elements are located on the outside of the panel. The HPA amplifies the input signals to output levels of about 5000 W.

The output signal from the HPA arrives at the Circulator Assembly, or switch matrix, on the top panel of the PEM. This matrix of ferrite circulators switches the signal coming from the HPA to any of the four antennas and on the return path directs the receive signal from the chosen antenna into the receive chain.

The waveguides from the switch matrix to the four antennas are lightweight CFRP units with a rectangular cross section of 4 cm x 2 cm, internally metallised. They are rigidly connected to the SAR antenna and the mid scatterometer antenna, while the connection to the deployable fore and

# ERS-1 DATA BOOK

aft antennas is by choke flanges, without a fixed connection. The 'receive' echo arrives at the 'receive' part of the IF Radar, via the circulator assembly, the receiver shutter – which safeguards the sensitive low-noise receiver against transmission pulse leakage – and the down-converter.

In nominal operation, the IF Radar works for both SAR and Scatterometer mode as an amplifier and filter stage. In SAR mode, however, onboard range compression can be commanded from the ground, which then switches the signal through an inverse dispersive delay line, compressing the echo pulses by a factor of about 590. Depending on the mode of operation, the output is fed to the SAR Processor or the Scatterometer Electronics.

The SAR Processor filters the signal and down-converts it to baseband. After analogue-to-digital conversion, auxiliary data are added, then the data are buffered and delivered to the IDHT for transmission to the ground. The SAR Processor additionally functions as the AMI's ICU. The Scatterometer Electronics also has two tasks. It filters and digitises the Wind Mode echoes and transfers them to the IDHT for transmission to ground. It also controls the AMI during Wind-Mode operation.

The echoes from the fore and aft antennas have rather a high Doppler shift, which varies from approximately 70 kHz to 150 kHz across the swath. This Doppler spread would prevent narrow-band filtering to reduce noise. The Scatterometer Electronics therefore, while the echoes are coming in, changes the local oscillator frequency according to the expected instantaneous Doppler shifts. This acts as Doppler compensation. This is also applied to the mid echoes, but here the required compensation is small.

Apart from providing a sample of the transmitted signal into the receiver for calibration purposes, the other task of the Calibration Unit is to delay a SAR transmit pulse and feed it back to the IF branch of the receiver. This signal is used as a replica of the chirped transmit pulse for on-ground range compression in the ground processor, as an alternative to the onboard range compression mentioned earlier. On-ground range compression is, in fact, the nominal operating mode.

## The AMI Antennas

The largest of the AMI antennas is the SAR antenna, with a radiating area of 10 m x 1 m. It is a slotted waveguide array made of metallised CFRP. The antenna itself is subdivided into ten electrical and five mechanical panels. Its planarity across its 10 m length will be better than  $\pm 1.5$  mm when in orbit.

The three Scatterometer antennas are made of aluminium alloy. Like the SAR antenna, they are slotted-waveguide

arrays, and each is subdivided electrically into two panels. The central unit, measuring 2.3 m x 0.34 m, contains eight waveguides, while the fore and aft arrays, measuring 3.6 m x 0.25 m, each contain six waveguides.

All of the antennas are designed for vertical polarisation.

## AMI Image-Mode (SAR) Characteristics

Bandwidth	15.55 $\pm$ 0.1 MHz
PRF range	1640–1720 Hz in 2 Hz steps
Long pulse	37.12 $\pm$ 0.06 $\mu$ s
Compressed pulse length	64 ns
Peak power	4.8 kW
Antenna size	10 m x 1 m
Polarisation	Linear-Vertical (LV)
Analogue/digital complex sampling	18.96 million samples/s
Sampling window	296 $\mu$ s (99 km telemetered swath)
Quantisation	5l, 5Q if range compression on ground (nominal 6l, 6Q if range compression on board)
Spatial resolution	30 m x 30 m
Radiometric resolution	2.5 dB at $\sigma_0 = -18$ dB
Swath stand-off	250 km to the side of the orbital track
Swath width	100 km
Incidence angle	23° at mid-swath
Frequency	5.3 GHz (C-band)
Data rate	<105 Mbit/s

## AMI Wave-Mode Characteristics

Wave direction	0–180° (180° ambiguity)
Wave length	100–1000 m
Accuracy	direction $\pm 20^\circ$ length $\pm 25\%$
Spatial sampling	5 km x 5 km every 200–300 km, programmable anywhere within the SAR swath
Incidence angle	23°
Frequency	5.3 GHz (C-band)
Polarisation	Linear-Vertical (LV)

## AMI Wind-Mode Characteristics

Wind direction range	0–360°
Accuracy	$\pm 20^\circ$
Wind speed range	4–24 m/s
Accuracy	2 m/s or 10%
Spatial resolution	50 km
Grid spacing	25 km
Swath stand-off	200 km to side of orbital track
Swath width	500 km
Frequency	5.3 GHz $\pm 200$ kHz
Polarisation	Linear-Vertical
Peak power	4.8 kW

## THE RADAR ALTIMETER (RA)

The Radar Altimeter is a nadir-pointing pulse radar designed to make precise measurements of the echoes from ocean and ice surfaces. It has two measurement modes, optimised for measurements over ocean and ice, respectively. In the so-called 'Ocean Mode', the echo characteristics of interest are:

- Time delay with respect to the transmitted pulse. This provides the measure of altitude.
- Slope of the echo leading edge, which is related to the height distribution of reflecting facets and thus to the ocean wave height.
- The power level of the echoed signal, which depends on small-scale surface roughness and thus on wind speed.

The radar echoes over ice sheets, particularly the rough surfaces at the continental margins, show much greater variances in shape than oceanic echoes. In order to make the best possible use of the data return in these areas, the 'Ice Mode' includes three features designed to improve its 'robustness'. The range window width is increased by a factor of four, which also degrades precision by a similar amount. A simplified height tracking loop greatly improves the ability to keep the echo in the range window, though it cannot distinguish the leading edge of the signal. Finally, the tracker is more agile.

In the Ice Mode, as in the Ocean Mode, the telemetered data stream contains the effective height of the range window, and the digitised echo waveform within this window. These allow ground-processing to retrieve topographic information. The returned power level is also telemetered.

The effective pulse width is 3 ns, which is equivalent to about 45 cm in two-way range. The radar is said to be 'pulse-width-limited' because not all of the target is illuminated simultaneously by the short pulse, and the received power is controlled by the illumination.

Over ocean surfaces, the distribution of the heights of reflecting facets is gaussian or near-gaussian, and the echo waveform has a characteristic shape that can be described analytically. It is a function of the standard deviation of the distribution, which is closely related to the ocean wave height.

Different echo waveforms occur over ice surfaces. Over sea ice, there is generally a strong specular component, while the rough topography of continental ice sheets at the margins leads to complex return waveforms. In central ice sheet areas, the height distribution becomes more regular and echoes similar to ocean returns are observed.

Real echoes are composed of the sums of signals from many point scatterers, each with individual phase and amplitude. To reduce uncertainties in the determination of pulse characteristics, the Radar Altimeter averages pulses together to reduce this statistical effect.

The constraints of available peak transmitter power and required pulse width determined that a pulse-compression technique be used to spread the required energy over time, allowing reduced peak power.

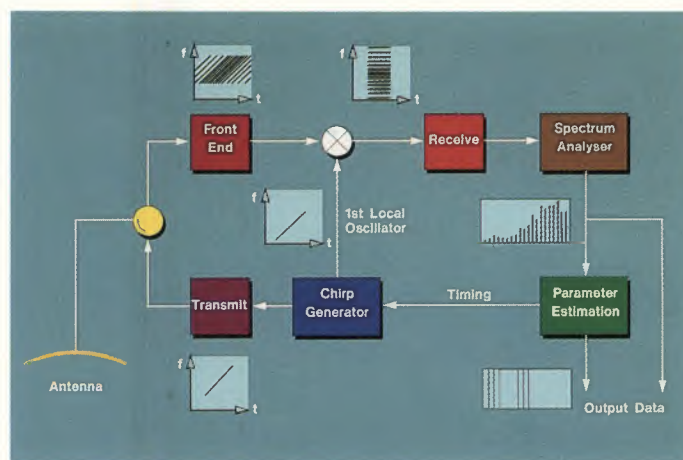

Schematic presentation of the Radar Altimeter's operating principle. The signal at various points is shown as a frequency/time plot.

## The RA Electronics

The Chirp Generator – which is based on Surface Acoustic Wave (SAW) devices – is triggered at a fixed rate of almost 1020 Hz. The chirps pass through a 20  $\mu$ s SAW delay line used to separate transmit and receive chirps during calibration. After up-conversion to the transmit frequency, they are amplified by the High-Power Amplifier, a 50 W Travelling Wave Tube (TWT). The pulses pass via the Front-End Electronics (FEE), which is an arrangement of circulators and the calibration coupler, to the antenna, a front-fed paraboloid.

Returning echoes arrive, via the antenna, FEE, and Low-Noise Amplifier (LNA), at the Microwave Receiver. When the echo is expected to return, the chirp generator is re-triggered and a second chirp generated. During the up-conversion and multiplication process, a slight frequency offset is introduced, and this becomes the first Intermediate Frequency (IF). This local oscillator chirp is mixed with the received echo in the 'deramping mixer' in the microwave receiver. A series of tones is thus generated, centred on the first IF.

## ERS-1 DATA BOOK

The microwave receiver is a dual-conversion system, and after conversion to baseband the in-phase (I) and quadrature (Q) signals are passed to the Signal Processor Sub-Assembly, or SPSA. The next important stage, inside the SPSA, is the spectrum analyser where the spectrum of the tones is found. This spectrum exactly represents the time structure of the echo waveform in 64 points at an equivalent spacing of 3.03 ns. The average power spectrum over fifty successive pulses is formed, and finally this information is used by the parameter estimator. This step is essential in order to provide the estimate of when the next echo is expected to return, for the chirp re-triggering. As an indication of the need for this estimate, the full bandwidth of the spectrum analyser is equivalent to a height window of about 30 m in the ocean mode. The maximum height rate is about 30 m/s; if the height estimate were not continually updated, the signal could be completely lost in about 1 s.

Sometimes the echo can be lost though, for example as a result of passing over some topographic surface such as mountains. In this case the acquisition mode is automatically entered. This is a sophisticated multi-stage scheme, partially relying on dedicated hardware processing, which virtually guarantees getting any trackable surface into the tracking mode range window in just over 1 s.

The parameter estimator is a microcomputer, within the SPSA. It is used in acquisition and tracking modes. In ocean and ice tracking, it is running software tracking loops which follow the signal characteristics. In the ocean mode, there are three main loops to track echo time-delay (height), leading-edge slope and echo power. The error signals used as input to these loops are derived from adaptive discriminators.

The time delay and echo power loop are also used in the Ice Mode, though the error signals are derived from different discriminators. Because of the reduced chirp bandwidth, the spectral points are spaced at 12.12 ns intervals, leading to a range window of about 115 m.

Internal open-loop calibration is performed every few minutes. This procedure is very fast (about 100 ms). The transmitted signal is coupled into the receiver through an attenuator, and analysis of the received signal is performed on the ground to determine the delay around the system. The major item omitted by this scheme is the Ultra-Stable Oscillator (USO), which provides the echo timing. This calibration is obtained by broadcasting the USO frequency via the IDHT to enable measurements to be made on the ground.

### Radar Altimeter (RA) characteristics

Frequency	13.8 GHz
Pulse length	20 $\mu$ s
Pulse rept. frequency	1020 Hz
Chirp bandwidth	330 MHz (sea) 82.5 MHz (ice)
Transmit power	55 W peak
Antenna diameter	1.2 m
Height noise	3 cm at 8 m wave height
Mass	96 kg
DC power	130 W

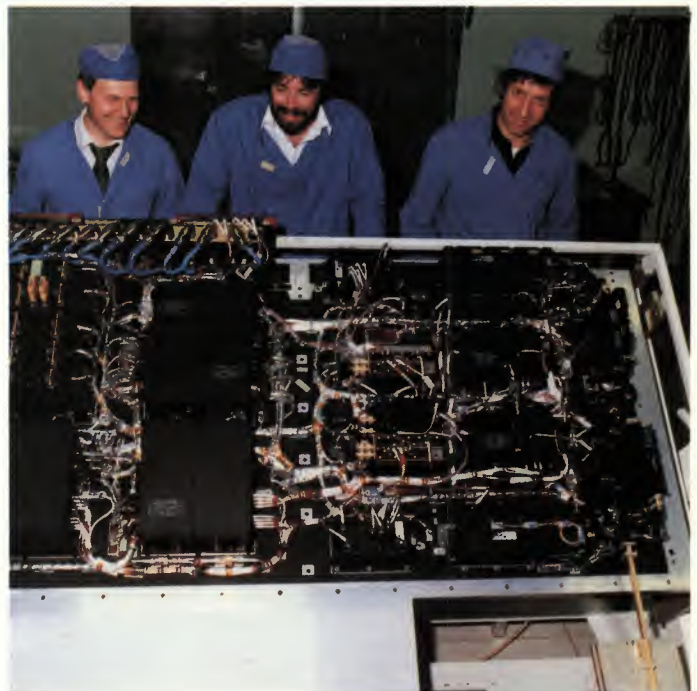

*The Radar Altimeter panel during instrument-level testing.*



# ERS - 1 DATA BOOK

## THE ALONG-TRACK SCANNING RADIOMETER AND MICROWAVE SOUNDER (ATSR-M)

Two instruments make up the ATSR-M; an Infrared Radiometer (IRR) and a Microwave Radiometer (MWR).

The Infrared Radiometer will be used to measure the global sea-surface temperature (SST), an important element for research into our climate. Its absolute accuracy will be better than 0.5 K when averaged over areas of 50 km x 50 km, assuming that 20% of pixels within the area are cloud-free. For the cloud-free pixels, of 1 km x 1 km, the relative accuracy will be about 0.1 K.

The IRR is an imaging radiometer with four co-registered channels with wavelengths of 1.6, 3.7, 11 and 12  $\mu\text{m}$ , defined by beam splitters and multilayer interference filters. The Instantaneous Field of View (IFOV) at the nadir on the Earth's surface is a 1 km x 1 km square, which is imaged onto the detectors via a f/2.3 paraboloidal mirror. These detectors, fixed onto a Focal-Plane Assembly, are cooled to 80 K by a Stirling-cycle cooler in order to reduce the background noise to an acceptable level.

The IFOV will be scanned over the Earth's surface by a rotating plane mirror in such a way that it gives two views of the Earth, namely a 0° or nadir, and a 57° or forward, view. The rotation period will be 150 ms and the scan will be subdivided into 2000 pixels of 75  $\mu\text{s}$  each.

In order to calibrate the optical and electrical signal chain, two black bodies (one hot and one cold) within the IRR will be scanned during the rotation. After onboard data compression, a packet of 960 pixels will be transmitted to ground, together with housekeeping and datation. Extensive on-ground data processing will then result in the availability of the final product, namely the sea-surface temperature (SST).

The main objective of the ATSR Microwave Sounder (MWR) will be to measure the atmospheric integrated water content (vapour and liquid) in order to compute the most problematic part of the tropospheric path delay in the Radar Altimeter's signals.

The MWR has two channels, operating at 23.8 and 36.5 GHz, each with a bandwidth of 400 MHz. The instrument will be nadir-viewing, using an offset antenna that will deploy shortly after the spacecraft's separation from the launcher. Onboard calibration will be performed by a sky horn pointing to cold space, and internal hot loads. The acquisition cycle will be synchronised to the ATSR scan occurrence and the MWR data will be merged into the IRR packets described above.

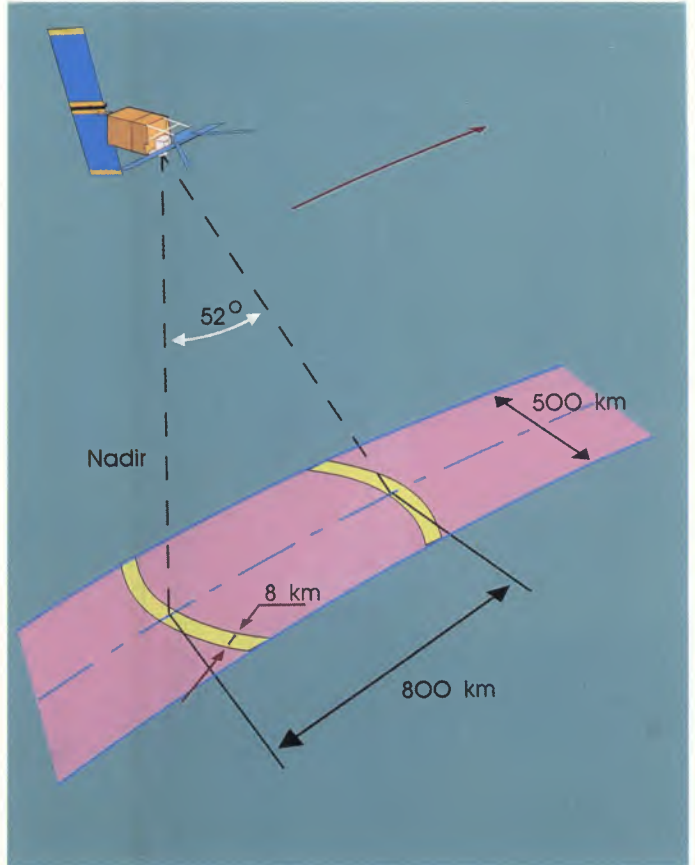

Measurement principle of the Along-Track Scanning Radiometer

### Along-Track Scanning Radiometer (ATSR) Characteristics

<b>IR Radiometer</b>	
Swath width	500 km
Spectral channels	1.6, 3.7, 11 and 12 $\mu\text{m}$
Spatial resolution	1 km x 1 km (at nadir)
Radiometric resolution	<0.1 K
Predicted accuracy	0.5 K over a 50x50 km <sup>2</sup> with 80% cloud cover
Conical scanning	
<b>Microwave Sounder</b>	
Channels	23.8 & 36.5 GHz
Instantaneous field of view	20 km
Near-nadir pointing	

## ERS-1 DATA BOOK

### THE LASER RETRO-REFLECTOR (LRR)

The Laser Retroreflector is a passive device which will be used as a target by ground-based laser ranging stations. The operating principle is to measure the time of a round trip of laser pulses reflected from an array of corner cubes mounted on the Earth-facing side of the spacecraft's Payload Electronics Module.

This array consists of a hemispherical housing with an arrangement of one nadir-looking corner cube in the centre, surrounded by an angled ring of eight corner cubes. This will allow laser ranging for satellite passes in the range of 0–360° azimuth and 30 to 90° elevation at the ground.

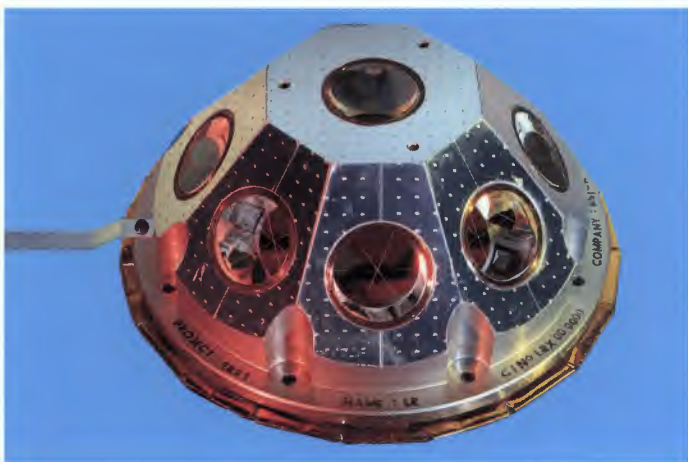

The Laser Retro-Reflector (LRR). Each corner cube is individually made to compensate for satellite motion in reflecting incident laser energy back exactly along its incoming path

#### Laser Retro-Reflector (LRR) Characteristics

Wavelength	350–800 nm optimised for 532 nm
Efficiency	≥ 0.15 end-of-life
Reflection coefficient	≥ 0.80 end-of-life
Field of view	elev. half-cone angle 60° azimuth 360°
Diameter	≤ 20 cm

#### PRARE Characteristics

Up-link	7225.296 MHz 10 Mbit/s PSK (10 MHz bandwidth)
Ground transponder	60 cm parabolic dish 2 W transmit power
Down-link	8489 MHz 10 Mbit/s PSK (10MHz bandwidth), 1 W transmit power
Satellite antennas	Crossed dipoles at X- and S-bands
Ranging accuracy	5–10 cm (predicted)

### THE PRECISE RANGE AND RANGE-RATE EQUIPMENT (PRARE)

The PRARE is a satellite tracking system which will perform two-way microwave range and range-rate measurements to ground-based transponder stations with high precision. Signal-propagation effects will be compensated by two-frequency measurements, for ionospheric refraction, and ground-station collection of meteorological data for tropospheric refraction.

Two signals will be transmitted to ground, one at S-band (2.2 GHz) and one at X-band (8.5 GHz) frequencies (both signals modulated with the pseudo-random noise code). The ground station will receive the two simultaneously emitted signals with a slight time difference and will determine the time delay. This will provide a measure of the ionospheric refraction taking place in the atmosphere.

The received signals will be demodulated and a coherent regenerated copy of the X-band (7.2 GHz) sequence will be retransmitted to the satellite, where the two-way travel time and the two-way Doppler measurements will be carried out, so that the range and range-rate can be determined. Two-way measurements will be possible for up to four stations simultaneously via so-called 'code multiplexing'.

Both the space-to-ground and ground-to-space links will have additional capacity for data transmission at low bit rates. Control codes and broadcast ephemerides for ground-station operation will be transmitted in the downlink, and calibration data, ionospheric-measurement results and meteorological ground data will be included in the uplink. All measurement data will be stored inside the PRARE itself, in 64 kbyte of RAM, and dumped during the next available ground-station pass.

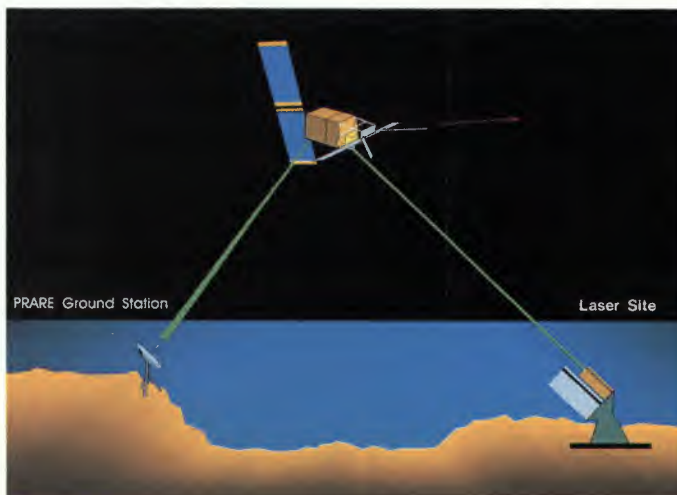

PRARE and Laser-retroreflector range measurement

---

## ERS-1 DATA BOOK

---

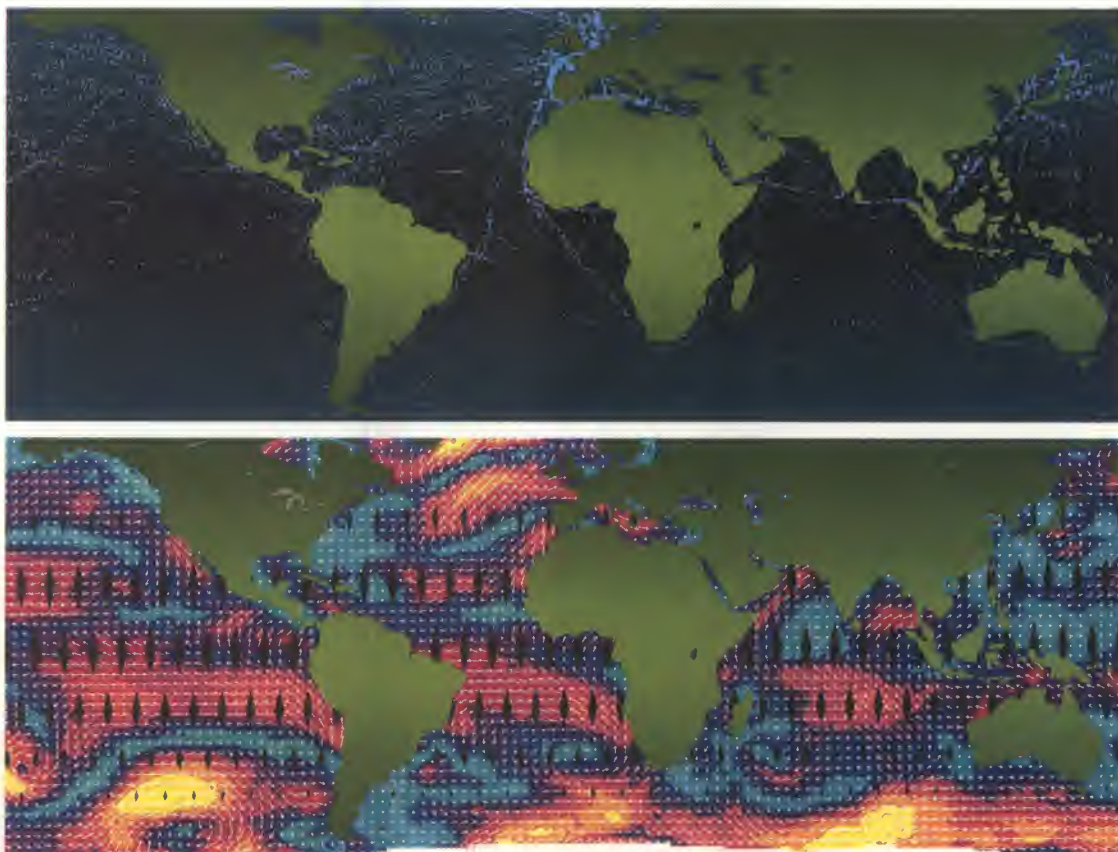

*Global wind fields. Top image: each blue dot represents one set of data provided every day by shipping. Bottom image: the global data coverage that is produced by ERS-1 every 72 hours.*

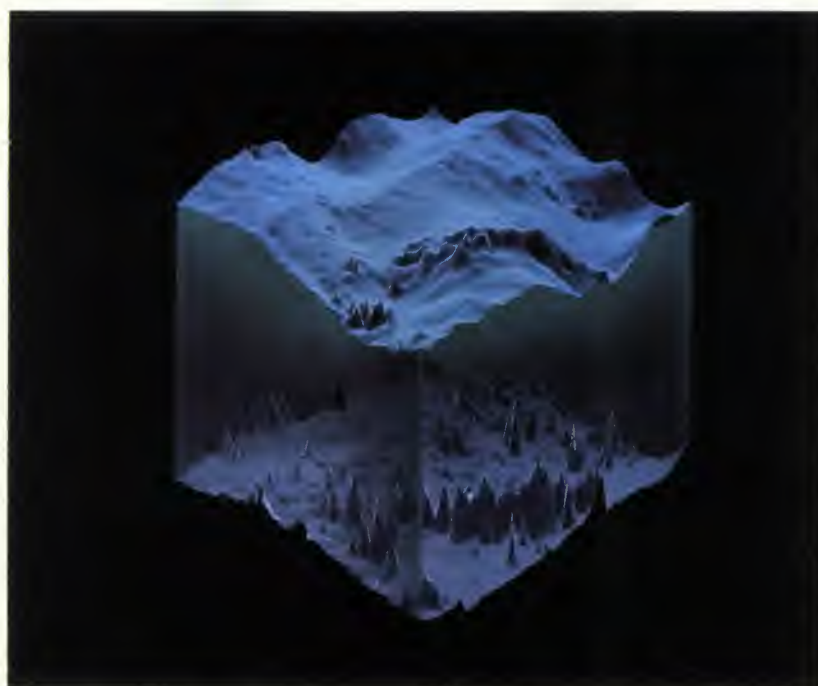

*A 5000 kilometer square model of the surface of the Atlantic, revealing how the ocean floor can be mapped from the surface features.*

## ERS – 1 DATA BOOK — Chapter 5 — Calibration and Validation

It is unusual that calibration and validation should merit a separate chapter, but such is the unique method adopted for ERS-1 that it deserves full coverage. This chapter is an update of the article published in ESA Bulletin No. 65.

The basic measurements to be made by ERS-1's instruments are sensor measurements of the following engineering quantities:

- radar backscattering from the Earth's surface (AMI, RA)
- time delay between transmission and echo reception (RA)
- infrared emission from the Earth's surface and the atmosphere (ATSR)
- microwave emission from the Earth's surface and the atmosphere (ATSR/M)
- satellite range and range-rate (PRARE).

It is from these *engineering* quantities that the *geophysical* data products will be derived, such as surface wind fields over the ocean, significant wave height, and directional ocean-wave spectra. As a consequence, the calibration and validation of the ERS-1 payload will take place in two distinct stages.

First the *engineering calibration* will be carried out, which is defined as the process of converting spacecraft payload telemetry into engineering units within known limits of accuracy and precision; e.g. radar backscattering coefficient ( $m^2/m^2$ ), antenna brightness temperature (K) and time delay (s). Engineering calibration is achieved via inherent instrument stability, the use of internal references to compensate for system variations caused mainly by temperature variations and ageing, and the use of external references such as specially designed radar transponders or carefully selected 'targets of opportunity'.

The second step will be *geophysical calibration*, the process of converting engineering quantities (e.g. radar backscattering) into geophysical units (winds and waves), within known limits of accuracy and precision. This conversion takes place in the ERS-1 ground processors and uses models to relate the engineering quantities to the geophysical quantities of interest.

ESA sponsored a number of C-band campaigns between 1983 and 1986 in which twenty institutes from six ESA Member States, Canada and the United States participated. The main goal was to provide data for the construction of an empirical vertically polarised C-band radar model. This model was to cover the whole range of operating conditions specified for the ERS Scatterometer. Flights involving typically ten circles were made, measuring the radar echoes over a range of incidence angles between 15 and 65°. Emphasis was placed on radar-system calibration and on comprehensive measurements and logging of ambient sea and air conditions. Measurements were

carried out in the German Bight, off the coast of Brittany, and in the Mediterranean, in the Straits of Gibraltar and Sicily.

The data gathered during these C-band campaigns consist of scatterometer and surface measurements defining surface wind speed and direction, as well as ocean-wave conditions.

The ESA-sponsored airborne scatterometer campaigns produced data sets showing good self- and mutual-consistency, a direct consequence of the simultaneous use of more than one radar, and the emphasis on calibration and surface support measurements. On the basis of these data, a vertical-polarisation radar-echo model was constructed which has been used in the design and performance assessment of the ERS-1 Scatterometer.

Nevertheless, these models cannot be determined with sufficient accuracy before launch, and in-situ measurements of wind and waves concurrent with ERS-1 overpasses will be necessary to calibrate or 'tune' them.

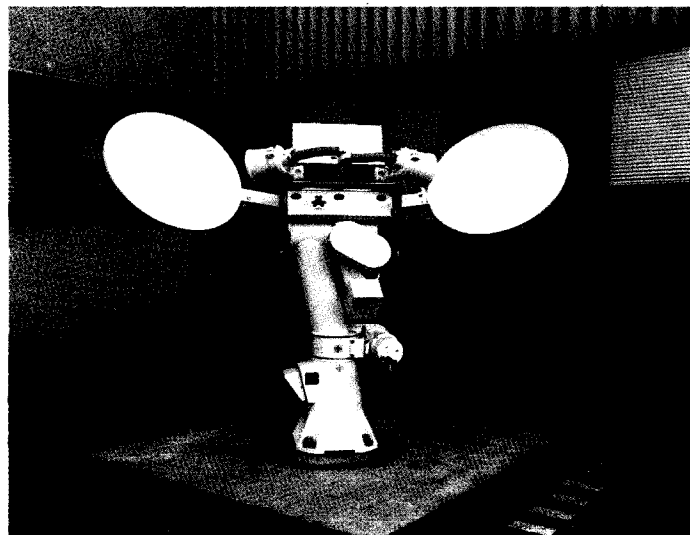

ESA scatterometer transponder during testing at ESTEC in Noordwijk (NL)

### Engineering calibration of the Active Microwave Instrumentation

The basic engineering measurement made by the AMI is that of radar backscattering coefficient ( $\sigma$ ,  $m^2/m^2$ ). In Image and Wave Mode, the AMI works as a Synthetic-Aperture Radar (SAR) and produces 30 m-resolution images. In Wind Mode, it functions as a real-aperture radar and produces three 50 km-

---

## ERS-1 DATA BOOK

---

resolution images virtually simultaneously for three different look directions.

To achieve engineering calibration, the AMI ground processors use pre-launch information about the instrument, such as its electronic gain and antenna patterns, ERS-1 orbit information, and in-flight measurements of, for example, instrument noise. Corrections are made for variations in electronic gain by adjusting the processor gain according to the in-flight response from the internal calibration unit. Antenna gain corrections are derived from transponder over-flights, which will be repeated frequently during the ERS-1 commissioning phase.

Three ESA transponders located in Flevoland (The Netherlands) will be used for calibration of the AMI Image and Wave Modes and three transponders in the south of Spain for the AMI Wind Mode.



*Flevoland SAR calibration site as seen by SEAsat in 1978*

Flevoland is located at about 52° N and is therefore revisited several times during the 35-day repeat orbit, thus providing good temporal resolution for calibration and performance monitoring. This area, which will also be covered by ERS-1 during the commissioning phase, consists of some 97 000 hectares of land reclaimed from the former 'Zuiderzee'. Because of its characteristic geometry, with relatively large-scale agriculture, the lack of relief, and the availability of many well-surveyed control points, the area has often been used for radar remote-sensing experiments and calibrations in the past.

In Spain, one of the transponders is located near a rocket-launching site operated by INTA, in Arenosillo. The second transponder is placed on the roof of the computer centre of the University of Malaga, and the third is mounted on the roof of a school in Adra.

The residual errors after radiometric calibration have been analysed in detail. The current prediction is that ERS-1's overall absolute radiometric accuracy for the Image Mode will be 0.7 dB (or  $\pm 9\%$ ), for the Wave Mode 0.5 dB, (or  $\pm 6\%$ ) and for the Wind Mode 0.5 dB (or  $\pm 6\%$ ).

### **Engineering calibration of the Radar Altimeter**

Pre-launch testing, characterisation and 'calibration' of the Radar Altimeter has been performed with the aid of a Return-Signal Simulator. This echo generator was attached to the Altimeter in place of the antenna, making it possible to test the instrument's performance with fully realistic echo signals. The echoes can represent ocean or any other surface, and can include realistic 'speckle effects' or simpler 'ideal echoes'. This test system was operated at the full pulse-repetition rate of the radar and was also able to simulate the acquisition sequence.

The height measurements from the Radar Altimeter will have a long-term stability of the order of 5 cm. An absolute system calibration to this level is not possible prior to launch, for a number of reasons including difficulties in calibrating the test equipment to the required accuracy. It is thus necessary to establish a calibration of the system bias in-orbit. Historically, this task has been performed twice before, for the Geos-3 and Seasat satellites, and bias values of the order of 0.5 m were found.

Of the many potential calibration techniques available, the best-known is the classical 'Bermuda method', in which the satellite overflies a laser-ranging system located on a small island. This was done for Seasat in 1978, but it is not without its difficulties, particularly when a calibration at the 5 cm level or better is required. It had been proposed that some of the potential problems could be overcome by moving the reference laser from an island to an offshore platform, but finding a platform large enough to support a laser system

## ERS-1 DATA BOOK

in European waters would essentially mean the North Sea. This region is considered unfavourable because of the likelihood of bad weather and high waves.

A different approach has therefore been adopted which makes maximum use of existing European facilities and capitalises on the density of existing satellite laser-ranging (SLR) stations in Europe.



*Calibration of the Radar Altimeter by comparing measured height over the Northern Adriatic with laser-ranging measurements from an array of laser stations*

The overall scenario is illustrated above. The satellite will make a northward pass over a small research platform, owned by CNR (the Italian National Research Centre) and used for oceanographic measurements, about 14 km offshore from Venice. It is fixed to the sea-bed in about 16 m of water in a part of the Adriatic free from significant dynamic sea-surface changes. The area has negligible currents, small and well-modelled tides, and only rarely, under storm conditions, is there appreciable wind set-up of the water surface. All of this is important because the satellite cannot be guaranteed to fly directly over the tower.



*The CNR Oceanographic Research Platform off the Italian coast, near Venice. The upper decks of the tower have since been modified to accommodate a PRARE station and microwave radiometer.*

Due to air-drag effects on its orbit, the satellite's ground track can vary by up to 1 km from the nominal track. The actual surface slope must be known in order to refer back to the reference platform's position. A further contribution to this surface slope stems from the detailed geoid in the area. An extensive series of measurements have been made in the area, and the construction of a very detailed local geoid has thereby been possible. This has confirmed a further advantage of the site: the local geoid is extremely smooth, with a small slope.

The satellite will be tracked from several satellite laser-ranging sites simultaneously. The figure in the previous column shows the fixed sites at Grasse (F), Graz (A), Matera (I), Wetzell (D) and Zimmerwald (CH). In addition, a new laser-ranging site has been established at Monte Venda in the Euganei Hills, south of Padova, housing the mobile laser-ranging station MTLRS-2 from the Technical University Delft (NL). These six lasers provide a network surrounding the Venice platform, with a favourable topology.

In addition to this network, two dedicated PRARE stations are planned, one to be co-located with the Venice laser, and the other on the tower itself, which has been extensively modified for this purpose.

---

## ERS-1 DATA BOOK

---

Other PRARE stations are already foreseen at Wettzell, Oberpfaffenhofen and Stuttgart, in Germany, for the baseline PRARE calibration/validation and operations.

As the main reference point for the sea-level determination, the Venice platform will be equipped with a number of measurement facilities. Some of these are permanent fixtures, such as a tide gauge, wave-measurement sensors, etc., while others will be specially installed for the purpose, including a microwave radiometer to measure atmospheric water vapour.



*The TU Delft (NL) mobile laser-ranging station, MTLRS-2, during pre-campaign testing at its home base in Kootwijk (NL)*

An extensive analysis of the errors to be expected during the calibration campaign has already been performed. Those of a random nature, varying from pass to pass, will be reduced by averaging the results over the duration of the campaign. The results of the analysis have shown that the Altimeter bias determination may be in error by up to about 5 cm at the end of the campaign, which is a significant improvement over the pre-launch value.

### **Engineering calibration of the Along-Track Scanning Radiometer**

The ATSR instrument has been tested and calibrated in a specially-designed space simulator and test facility at the Department of Atmospheric, Oceanic and Planetary Physics of Oxford University (UK). While there, the instrument was subjected to a series of tests covering field-of-view deter-

mination, radiometric calibration, thermal-vacuum temperature cycling, and thermal-balance tests, in addition to standard instrument checkouts.

The ATSR was bolted to a 'PEM simulator', which was maintained at the predicted in-orbit temperature of the Payload Electronics Module (PEM) surface, to which the instrument will be attached. An Earth-shine plate simulated infrared and reflected solar radiation from the Earth, and a drum baffle (maintained at the same temperature as the Earth-shine plate) shielded the instrument from radiation from the inside of the test chamber at room temperature. Finally, a cold-box, surrounding the remaining four sides of the instrument, simulated the integrated thermal/reflected couplings to space.

Two external calibration targets (one positioned in each of ATSR's two viewing directions) were mounted on the Earth-shine plate. Since the instrument was to be calibrated at all positions around the scan, the whole Earth-shine plate assembly (which weighed about 1/4 t) was able to rotate by  $\pm 50^\circ$  about its central position.

The temperature of the external targets could be controlled between 243 and 310 K, thus covering the required sea-surface and warm cloud-top temperature ranges. Using this experimental set-up and the full range of external target temperatures, it was possible to calibrate the ATSR for a variety of thermal environments, positions around the scan, detector temperatures and on-board black-body temperatures. Furthermore, the linearity of each channel, the consistency between the different channels, and possible radiometric leaks were also investigated. In addition, one of the external targets had the facility to be cooled by liquid nitrogen to allow a low-radiance calibration measurement.

To meet its scientific objective of measuring sea-surface temperature to better than 0.3 K, the ATSR has to measure brightness temperature in the infrared to better than 0.1 K. The radiometric tests showed that this was achieved over the entire sea-surface temperature range, with no scan-dependent strays or biases.

The commissioning phase will begin approximately two days after the satellite's launch and is expected to last for three months. Initially, only brief functional checks will be carried out on the ATSR, including a fairly short period of cooler operation, to avoid condensation onto the detectors of outgassing products from plastics, etc. After about two weeks in orbit, this problem should be less severe and longer periods of cooler operation will begin. A full checkout of the Microwave Radiometer will be possible in this period as it does not require the cooler to be switched on. After the detectors have been cooled to normal operating temperature, a range of checks will be carried out to verify.

## ERS-1 DATA BOOK

instrument performance and to optimise certain parameters.

A full functional check of the ATSR subsystems will only be possible once the detectors have been cooled to normal operating temperature. Apart from the basic power and hardware functions, these checks will look closely at the on-board black-body and cooler performances and will verify the software-control functions and science-data generation.

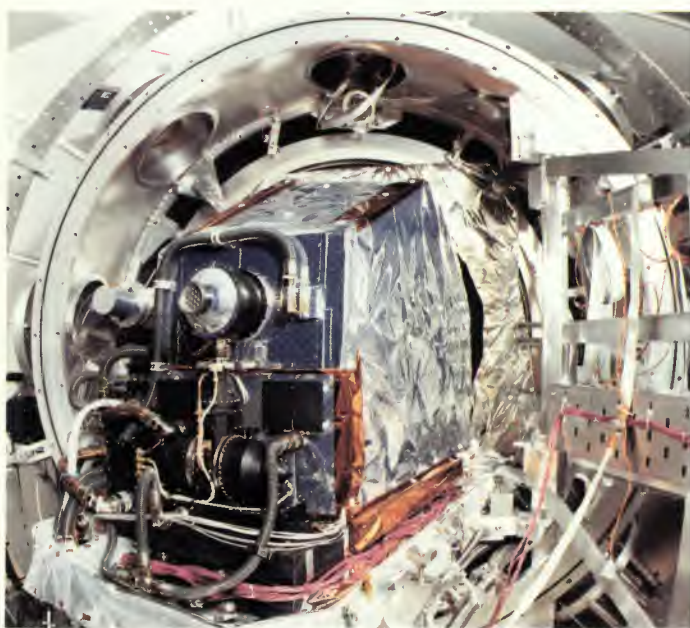

*The ATSR in the Oxford University (UK) space simulator test facility*

Primary calibration of the IRR instrument will be achieved with two on-board black bodies which will stabilise at temperatures of around 263 K and 303 K, respectively. The black-body temperature is measured accurately by platinum-resistance thermometers, and each black body is seen once per scan of the optical system. The 1.6 micron (near-infrared) channel will be calibrated by observing ground features that have known albedos. One such site is the White Sands Missile Range in New Mexico, which will need to be observed in sunlight when cloud is absent. The exact site used will depend on the final choice of orbit and will not be known until nearer the launch date. Drift and noise in the near-infrared channel can be assessed from data taken at night.

Calibration of the thermal channels involves close observation of the on-board black-body performance and the thermal environment within the instrument. A comparison can then be made with the performance of the detectors during the ground calibration, and any necessary corrections made. The way in which each channel responds to sharp

changes in ground temperature will be found from data collected over cloud/sea and sea/land boundaries.

Instrument tests on the Microwave Sounder (ATSR/M) will be performed at the beginning of the commissioning phase and several times during the satellite's lifetime. They will include:

- a survey of the instrument stability with time (gain, internal temperatures, horns)
- checking of the sky-horn measurements during one special orbit
- examination of antenna-pointing and sidelobe-contamination effects.

Validations of brightness temperature will be performed twice during the commissioning phase and several times during the satellite's lifetime. Observed brightness temperatures will be compared with those computed using a radiative transfer model applied to meteorological fields (ECMWF model analyses) at co-located points (two weeks' worth of data).

The validation of geophysical data will be based essentially on the comparison of calculated water-vapour content with observations from radio-sounding (provided by the French Meteorological Office). This will be done twice during the commissioning phase and occasionally during the satellite's lifetime, in order to sample all possible meteorological conditions.

The liquid-water measurements cannot be validated, except by using aircraft profiles in clouds, and this problem is the subject of further studies.

Other validations will be performed using available data such as the Special Sensor Microwave Imager products (from the SSMI instruments flown on NOAA operational satellites), and ground-based microwave radiometer data (campaign planned for August 1991 with CNES's 'Portos' radiometer).

### **Engineering calibration of the Precise Range and Range-rate Equipment (PRARE)**

Although the PRARE space segment and ground tracking units contain facilities for the determination of hardware-related calibration parameters for each measurement interval, there is also a strong requirement for a calibration procedure to monitor the overall performance of the tracking measurements against the most precise laser systems, and to tie the PRARE observations into the internationally accepted standard of laser tracking measurements.

The calibration procedure selected is based on comparative measurements to the ERS-1 satellite from the two



---

# ERS-1 DATA BOOK

---

tracking systems, laser and PRARE, installed adjacent to each other on the Wettzell tracking-station site, in Bavaria (D). This station has extensive experience of co-location campaigns for stationary and mobile laser systems.

It is planned to conduct an intensive calibration campaign during the ERS-1 commissioning phase in order to derive the most reliable calibration parameters and to use the co-location setup during the subsequent exploitation phase to monitor the system's behaviour.

The calibration experiment will be executed jointly by the PRARE experimenter team from the Deutsches Geodätisches Forschungsinstitut and Institut für Navigation, Universität Stuttgart, and the Institut für Angewandte Geodäsie in Frankfurt, which operates the Wettzell station.

Before the start of the ERS-1 mission a new, upgraded laser system will be available capable of:

- satellite tracking with an accuracy of  $\pm 1$  cm
- lunar tracking with an accuracy of  $\pm 3$  cm.

A water-vapour radiometer will also be available before the start of the ERS-1 mission.

Satellite laser-ranging systems nowadays comply with high accuracy standards. By using simple passive retro-reflector ground targets, they can be reliably calibrated in a straightforward manner and their measurements, in contrast to microwave ranging, do not depend on the ionospheric conditions, and are much less influenced by the difficult-to-model water-vapour content of the troposphere. Consequently, they make an extremely good reference system for the calibration of the PRARE. However, they are susceptible to loss of data due to cloud or haze effects, and a laser-ranging installation is relatively large and involves a significant infrastructure, in contrast to the PRARE.

## **Geophysical calibration of ERS-1**

The geophysical data products produced routinely by the ERS-1 instruments will include the speed and direction of the surface winds over the ocean and the directional spectrum of the ocean waves derived from radar backscattering measurements from the AMI, and the significant wave height and the surface wind speed derived from the radar echo signals measured by the Radar Altimeter.

The models used to convert radar signals into the above wind and wave parameters will be checked and, where necessary, modified by comparing the satellite-derived estimates with the analysis fields derived from meteorological and oceanographic models on both a regional and a global scale. This activity is being carried out in cooperation with the European Centre for Medium-Range Weather Forecasting (ECMWF) and the major

Meteorological Offices in Europe. A large database will be built up from routine in-situ observations by ships and buoys and co-located satellite observations. This data set will be available for making a quality assessment of the ERS-1 wind and wave products and for detailed analysis of the ERS-1 interpretation models on a global scale.

In addition, a dedicated field campaign will be conducted at an ocean site off the Norwegian Coast, near Trondheim.

An array of meteorological buoys will be deployed there for measuring wind speed, wind direction and significant wave height during the ERS-1 overpasses. Low-flying aircraft will also be used to make complementary wind-vector measurements. These aircraft will also carry airborne radars to verify both the wind-retrieval and the ocean-wave imaging models used for ERS-1 data.

Research vessels will be used for in-situ wind and wave measurements, and the shipborne radars will image the ocean surface during ERS-1 overpasses to determine the ocean wave field. Similar surface measurements and airborne observations are planned in collaboration with non-European organisations in Canada, the USA and Australia.

Simulations indicate that, after a three-month geophysical calibration period, sufficient data will be available to determine and verify the geophysical performance of the operational ERS-1 wind and wave retrieval models.