

	<p>COSMO-SkyMed Mission and Products Description</p>	<p>Doc. N° : ASI-CSM-PMG-NT-001 Date : 31 May 2016 Rev. : Issue 2 Pag. : 1 of 151</p>
<p>PROGRAMMA COSMO-SkyMed</p>		

Italian Space Agency



***COSMO-SkyMed
Mission and Products Description***





 	COSMO-SkyMed Mission and Products Description	Doc. N°. : ASI-CSM-PMG-NT-001 Date : 31 May 2016 Rev. : Issue 2 Pag. : 2 of 151
PROGRAMMA COSMO-SkyMed		

Document Status Sheet



ISSUE	DATE	AUTHOR	CHECK	REASON(S) FOR CHANGE
0	05/09/2013	C. Fiorentino M. Virelli	F. Caltagirone A. Coletta G.F. De Luca	First Issue
1	14/01/2013	M. Virelli	F. Caltagirone	Insertion of the date of issuing
2	31/05/2016	C. Fiorentino M. Virelli	A. Coletta	Various update

 	COSMO-SkyMed Mission and Products Description	Doc. N°. : ASI-CSM-PMG-NT-001 Date : 31 May 2016 Rev. : Issue 2 Pag. : 3 of 151
PROGRAMMA COSMO-SkyMed		

DOCUMENT STATUS SHEET	2
1 SCOPE OF THE DOCUMENT	5
2 COSMO-SKYMED OVERVIEW	6
2.1 THE MISSION.....	7
2.2 THE SATELLITE	9
2.3 THE SAR.....	10
2.3.1 SAR instrument acquisition mode characteristics.....	11
2.3.2 SAR beams geometrical characteristics.....	13
2.4 THE GROUND SEGMENT	16
2.4.1 CPCM.....	16
2.4.2 C-UGS.....	16
2.4.3 Receiving Stations.....	17
2.4.4 System Calibration.....	17
3 SYSTEM PERFORMANCES	19
3.1 ARCHIVE AND PRODUCT CAPABILITY	19
3.2 TIME PERFORMANCES	20
4 COSMO-SKYMED SAR PRODUCTS OVERVIEW	22
4.1 THE COSMO-SKYMED SAR IMAGING MODES	22
4.2 THE MAJOR CLASSES OF COSMO SAR PRODUCTS.....	23
5 PRODUCTS DESCRIPTION	27
5.1 STANDARDS PRODUCTS.....	27
5.1.1 COSMO-SkyMed Product Detail.....	29
5.1.2 COSMO-SkyMed Standard Products current performances.....	30
5.2 HIGHER LEVEL PRODUCTS	32
5.2.1 Quick Look Products	32
5.2.2 Speckle Filtered Products.....	33
5.2.3 Co-registered Products	34
5.2.4 Mosaicked Product	35
5.2.5 Interferometric Products.....	36
5.2.6 DEM Products	37
5.2.7 Distribution Media.....	38
5.3 SERVICE PRODUCTS	38
6 STANDARD PRODUCTS FORMAT DESCRIPTION	40
6.1 FORMAT OVERVIEW	40
6.1.1 Groups.....	40
6.1.2 Datasets	41
6.1.3 HDF5 Attributes.....	43
6.2 PRODUCTS ORGANIZATION	43
6.2.1 Naming Convention	43
6.2.2 Hierarchies organization.....	45
6.2.3 Graphical representation of the hierarchical organization for each Instrument Mode and Processing Level.....	46
6.2.4 Quick Look layer	51



 	COSMO-SkyMed Mission and Products Description	Doc. N°. : ASI-CSM-PMG-NT-001 Date : 31 May 2016 Rev. : Issue 2 Pag. : 4 of 151
PROGRAMMA COSMO-SkyMed		

6.2.5	Ancillary information organization.....	52
6.2.6	Data storage policy.....	52
7	HIGHER LEVEL PRODUCTS FORMAT DESCRIPTION.....	54
7.1	QUICK-LOOK PRODUCT.....	54
7.2	SPECKLE FILTERED PRODUCTS.....	55
7.2.1	Output Format.....	55
7.3	CO-REGISTERED PRODUCT.....	56
7.3.1	Output Format.....	56
7.4	INTERFEROMETRIC PRODUCTS.....	57
7.4.1	Output Format.....	57
7.5	DEM PRODUCT.....	60
7.5.1	Output Format.....	60
7.6	MOSAICKED PRODUCT.....	62
7.6.1	Output Format.....	62
8	APPENDIX 1: COSMO-SKYMED IMAGE CALIBRATION.....	64
9	APPENDIX 2: PRODUCT ATTRIBUTES.....	67
10	ACRONYMS AND GLOSSARY.....	149
10.1	ACRONYMS.....	149
10.2	GLOSSARY.....	150

 	COSMO-SkyMed Mission and Products Description	Doc. N°. : ASI-CSM-PMG-NT-001 Date : 31 May 2016 Rev. : Issue 2 Pag. : 5 of 151
PROGRAMMA COSMO-SkyMed		

1 Scope of the Document

Scope of this document is to provide the COSMO-SkyMed Users with a System Description giving an overview of the Constellation's main characteristics and performances, and is to provide COSMO-SkyMed System Users with a SAR Product Handbook giving a detailed description of the COSMO SAR Products.

 	COSMO-SkyMed Mission and Products Description	Doc. N°. : ASI-CSM-PMG-NT-001 Date : 31 May 2016 Rev. : Issue 2 Pag. : 6 of 151
PROGRAMMA COSMO-SkyMed		

2 COSMO-SkyMed Overview

COSMO-SkyMed (CONstellation of small Satellites for Mediterranean basin Observation) is the largest Italian investment in Space Systems for Earth Observation. It is a Dual-Use (Civilian and Defence) end-to-end Earth Observation System aimed at establishing a worldwide service providing data, products and services compliant with well-established international standards and relevant to a wide range of applications, such as Emergency and Risk Management, Scientific and Commercial Applications and Defence Applications.

The system consists of a constellation of four Low Earth Orbit mid-sized satellites, each equipped with a multi-mode high-resolution Synthetic Aperture Radar (SAR) operating at X-band and fitted with particularly flexible and innovative data acquisition and transmission equipment.

The system is completed by dedicated full featured Ground infrastructures for managing the constellation and granting ad-hoc services for collection, archiving and distribution of acquired remote sensing data.

The four COSMO-SkyMed satellites have been successfully launched the 8th of June, the 9th of December 2007, the 25th of October 2009 and the 6th of November 2010 respectively.

The Constellation started operations in September 2008, with the deployment of the first two satellites qualified in orbit. The deployment of the complete constellation onto operations, with four satellites qualified in orbit, was completed in January 2011.



COSMO-SkyMed Mission offers today an efficient response to actual needs of Earth Observation Market providing an asset characterized by full global coverage, all weather, day/night acquisition capability, higher resolution, higher accuracy (geo-location, radiometry, etc.), superior image quality, fast revisit/response time, interferometric/polarimetric capabilities and quicker-and-easier ordering and delivery of data, products and services.

The system is conceived to pursue a Multi-mission approach thanks to its intrinsic Inter-operability with other EO missions and Expandability towards other possible partners with different sensors typologies to implement an integrated space-based system providing Earth Observation integrated services to large User Communities and Partner Countries (IEM capability).

These features designate COSMO-SkyMed as a system capable to provide “Institutional Awareness” in order to make proper decisions in preventing and managing world-wide crisis.

In a Dual-Use environment, particular emphasis has to be put on Dual-Use Mission Planning functionality in order to optimize system utilization and fulfilling at the same time different user classes needs: an insight into the peculiar characteristics of the COSMO-SkyMed Dual-Use Mission Planning and the technical methodology approach to the sharing of System Resources in a Multi-User setting is provided.

Following chapters give a quick overview about the COSMO-SkyMed mission objectives and design.

 	COSMO-SkyMed Mission and Products Description	Doc. N°. : ASI-CSM-PMG-NT-001 Date : 31 May 2016 Rev. : Issue 2 Pag. : 7 of 151
PROGRAMMA COSMO-SkyMed		

2.1 The Mission

The mission objectives of COSMO-SkyMed are related to a space mission having a dual nature (i.e. capable to satisfy civilian and defence customers) able to provide on a worldwide basis information and services to a number of activities and applications, such as Risk Management Applications, Cartography and planning applications, agriculture, forest, hydrology, Geology, Marine domain, Archaeology etc.

In particular primary Mission objective is thus to meet Customer's needs, under economical, schedule and political constraints, for a space borne Earth Observation System capable to provide:

- Environmental Risk and Security Management for both civilian Institutional and Defence needs, through monitoring and surveillance applications assessing exogenous, endogenous, and anthropogenic risks.
- Provision of commercial products and services (e.g. for agriculture, territory management) to world-wide civilian user community

In order to reach these objectives the system has been conceived with the following main features:

- It is able to acquire images all over the world in every atmospheric condition during night and day,
- It is able to produce a wide number of images with high resolution, accuracy (geolocation, radiometry etc.) and quality,
- It is able to produce images for polarimetric and interferometric applications,
- It is able to acquire images with very short revisit and response times according to a specific product order.



Obviously this document will discuss only details relevant to the Civilian Users.

Indeed COSMO-SkyMed Space Segment, at fully deployed constellation (4 satellites), is capable to collect up to 1800 images per day; the Civilian Ground Segment is currently able to archive up to 475 images per day and to process 200 level 1C/1D products per day. Obviously the Ground Segment capacity can be scaled in order to fully exploit the constellation capacity when needed.

In order to supply data for a wide variety of application that range from cartography to emergency response the SAR payload has been designed to acquire a scene in three different modes according to the image area and the resolution that can be obtained:

- SPOTLIGHT, high resolution and small image area;
- STRIPMAP (HIMAGE and PING-PONG), medium resolution and medium image area;
- SCANSAR (WIDE and HUGE REGION), lower resolution and large image area.

the following picture (Fig. 1) are sketched the swath and resolution for each acquisition mode.

 	COSMO-SkyMed Mission and Products Description	Doc. N°. : ASI-CSM-PMG-NT-001 Date : 31 May 2016 Rev. : Issue 2 Pag. : 8 of 151
PROGRAMMA COSMO-SkyMed		

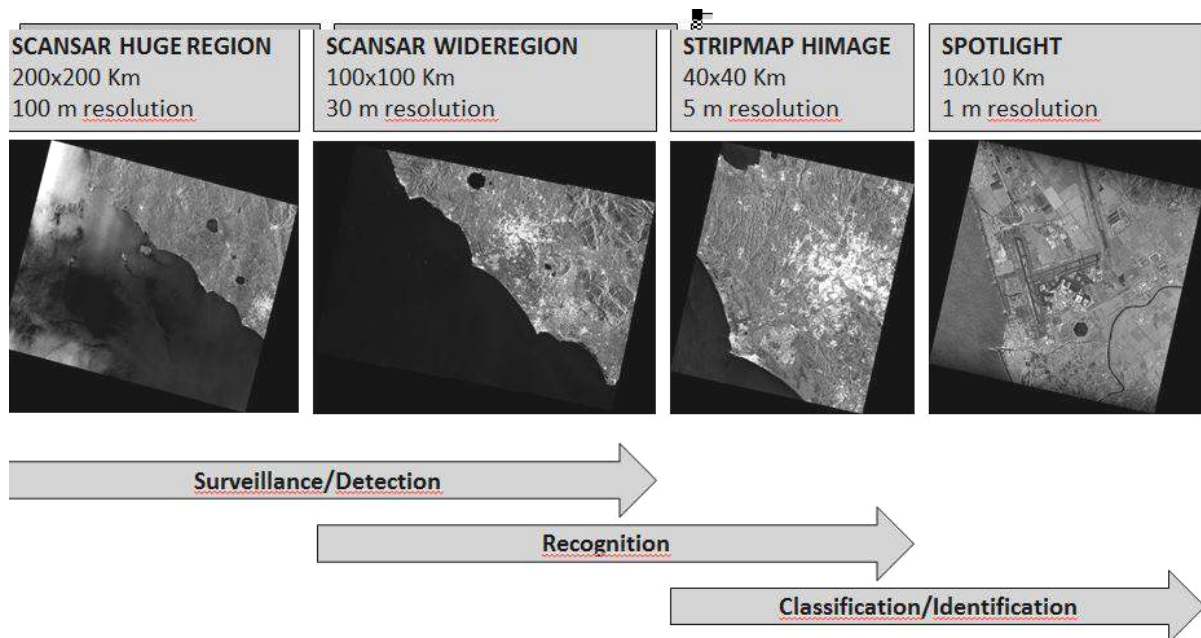

Figure 1 – The acquisition modes of COSMO-SkyMed sensor

The constellation consists of 4 medium-size satellites, each one equipped with a microwave high-resolution synthetic aperture radar (SAR) operating in X-band, having ~630 km access ground area.

The orbit characteristics are summarized in the following table.



Orbit Type	SSO
Inclination	97.86°
Revolutions/day	14.8125
Orbit Cycle	16 days
Eccentricity	0.00118
Argument of Perigee	90°
Semi Major Axis	7003.52 km
Nominal Height	619.6 km
LTAN	6:00 A.M.
Number of Satellites	4

Table 1 - Orbit characteristics

In nominal conditions, the four satellites are in the same orbital plane and currently positioned as depicted in the following figure:



COSMO-SkyMed Mission and Products Description

 	COSMO-SkyMed Mission and Products Description	Doc. N° : ASI-CSM-PMG-NT-001 Date : 31 May 2016 Rev. : Issue 2 Pag. : 10 of 151
PROGRAMMA COSMO-SkyMed		

Transmission of the Science Data generated by the SAR payloads on-board COSMO-SkyMed satellites. It includes all the necessary interfaces for acquiring telecommands and ancillary data from ICS and for storage, formatting, encryption and ground downlink of the science data from the SAR instrument

The satellite benefits from an extensive heritage coming from other synergetic and strategic programs developed in the Italian context: the platform is derived from the reconfigurable multi-application platform PRIMA, and the SAR P/L directly derives from SAR2000 technological programme.

The platform architecture has been conceived to monitor each on-board equipment, to collect and distribute data to all the satellite unit, to receive and decrypt telecommands sent from the ground, to control the attitude and the orbit manoeuvres and for the transmission of satellite telemetries and the images to the ground stations. One of the main characteristics of the platform is its agility since it makes possible acquisitions in left and right looking allowing to extend the access area of the System. This can be obtained by an attitude manoeuvre. The nominal side looking mode is the right looking.

The following Figure shows the COSMO-SkyMed satellite in fully deployed configuration and in “stowed” configuration, i.e. when it is mounted in the launcher.

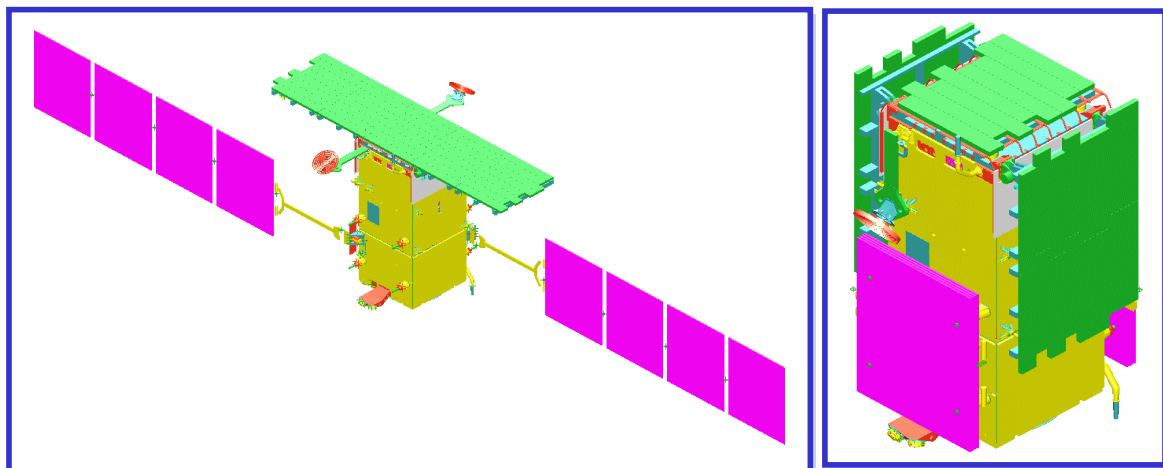



Figure 3 - SAR Satellite (Deployed and Stowed Configurations)

2.3 The SAR

The COSMO - SkyMed satellite main payload is an X-band, multi-resolution and multi-polarisation imaging radar, with various resolutions (from 1 to 100 meters) over a large access region. It is equipped with a fixed antenna, having electronic steering capabilities that can manage a large number of operative modes for the image acquisition and for internal calibrations.

The nominal incidence angles (where the system grants the image quality requested) vary between 20° and 59°. The access area can reach 630 km.

In the following paragraph the SAR is described in further details, with special regards to its acquisition mode and beams geometrical characteristics.

 	COSMO-SkyMed Mission and Products Description	Doc. N°. : ASI-CSM-PMG-NT-001 Date : 31 May 2016 Rev. : Issue 2 Pag. : 11 of 151
PROGRAMMA COSMO-SkyMed		

2.3.1 SAR instrument acquisition mode characteristics

The sensor imaging operating modes are:

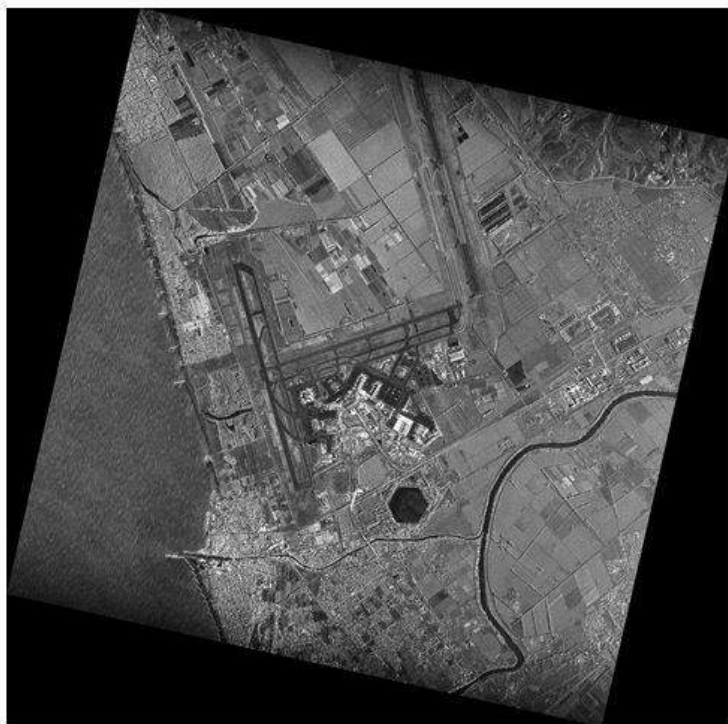

Spotlight Mode, in which the antenna is steered (both in the azimuth and the elevation plane) during the overall acquisition time in order to illuminate the required scene for a time period longer than the one of the standard strip side view, increasing the length of the synthetic antenna and therefore the azimuth resolution (at expense of the azimuth coverage). In such configuration the acquisition is performed in frame mode, hence it is limited in the azimuth direction due to the technical constraints deriving from the azimuth antenna pointing. The implementation allowed for this acquisition mode is the Enhanced Spotlight. In the Enhanced Spotlight mode, the spot extension is achieved by a antenna electronic steering scheme requiring the centre of the beam steering to be located beyond the centre of the imaged spot, thus increasing the observed Doppler bandwidth for each target. Such mode is characterized by an azimuth frame extension of about 10 Km, a range swath extension about 10 Km, PRF values ranging from a minimum of about 3 kHz to a maximum of about 4 kHz, allowed chirp duration in the range [70, 80] microseconds (depending on specific access area. Find here below an example of Enhanced Spotlight mode acquisition with the relevant characteristics briefly summarized.



SPOTLIGHT	
Resolution (m)	1
Scene size (Km)	10 x 10
Polarization (T/R)	SINGLE, HH or VV
Incidence angles (deg)	20.0 – 59.5

Figure 4 – Spotlight mode

Stripmap Mode, which is the most common imaging mode (similar to ERS mission one), obtained by pointing the antenna along a fixed direction with respect to the flight platform path. The antenna footprint covers a strip on the illuminated surfaces as the platform moves and the system operates. The acquisition is virtually unlimited in the azimuth direction, except for the limitations deriving from the SAR instrument duty cycle (about 600 seconds, allowing a strip length of 4500+ km). Two different implementation of this mode are foreseen: the Himage and the PingPong. In the Himage mode, the radar Tx/Rx configurations are time invariant, allowing receiving from each ground scatterer the full Doppler bandwidth allowed by the azimuth aperture of the antenna beamwidth. The Himage is characterized by a swath width of about 40 km, an azimuth extension for the standard product (square

 	COSMO-SkyMed Mission and Products Description	Doc. N°. : ASI-CSM-PMG-NT-001 Date : 31 May 2016 Rev. : Issue 2 Pag. : 12 of 151
PROGRAMMA COSMO-SkyMed		

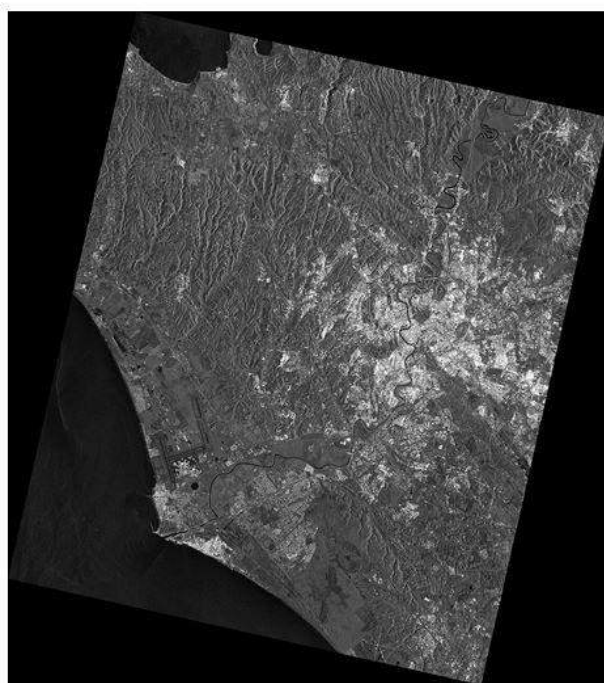

frame) about 40 Km (corresponding to an acquisition of about 7 sec), PRF values ranging from a minimum of about 3 kHz to a maximum of 4 kHz, a chirp duration in the range [35, 40] microseconds, a chirp bandwidth accommodated along range on the basis of the required ground resolution, spanning from about 65 MHz at the far range to about 140 MHz at the far range. The PingPong mode implements a strip acquisition by alternating a pair of Tx/Rx polarization across bursts (cross-polarization) obtained by mean of the antenna (which may be adjusted to be different on transmit and on receive). The acquisition is hence performed in strip mode alternating the signal polarization between two of possible ones i.e. VV, HH, HV and VH. In this polarimetric burst mode only a part of the synthetic antenna length is available in azimuth and consequently the azimuth resolution is reduced. This mode is characterized by a swath width value of about 30 km, an azimuth extension for the standard product is about 30 Km (square frame) corresponding to an acquisition of about 6 sec, PRF values ranging from a minimum of about 3 kHz to a maximum of about 4 kHz, a chirp duration fixed at 30 microseconds. Find here below an example of STRIPMAP mode acquisition with the relevant characteristics briefly summarized.



	STRIPMAP HIMAGE	STRIPMAP PING PONG
Multi-look resolution (m)	5	20
Scene size (Km)	40 x 40	30 x 30
Polarization (T/R)	SINGLE, HH or HV or VH or VV	ALTERNATING, HH/VV or HH/HV or VV/VH
Incidence angles (deg)	18.0 – 59.8	18.86 – 59.49

Figure 5 – Stripmap mode

ScanSAR Mode, which allows larger swath in range with respect to the Stripmap one, but with a less spatial resolution, obtained by periodically stepping the antenna beam to neighbouring sub-swaths. Since only a part of the synthetic antenna length is available in azimuth, the azimuth resolution is hence reduced. In such configuration the acquisition is performed in adjacent strip mode, hence it is virtually unlimited in the azimuth direction, but for the limitations deriving from the SAR instrument duty cycle that is of about 600 seconds. The two different implementation are allowed for this acquisition mode are WideRegion and HugeRegion. In the WideRegion mode the grouping of acquisition over three adjacent subswaths allows achieving ground coverage of about 100 Km in the range direction. The azimuth extension for the standard product is about 100 Km (hence envisaged for the origination of a square frame) corresponding to an acquisition of about 15.0 sec. This mode is characterized by PRF values ranging from a minimum of about 3 kHz to a maximum about 4 kHz, a chirp duration in range [30, 40] microseconds, a chirp bandwidth accommodated along range on the basis of the required ground

 	COSMO-SkyMed Mission and Products Description	Doc. N°. : ASI-CSM-PMG-NT-001 Date : 31 May 2016 Rev. : Issue 2 Pag. : 13 of 151
PROGRAMMA COSMO-SkyMed		

resolution and spanning from about 30 MHz at the far range to about 90 MHz at the far range. In the HugeRegion mode the grouping acquisition over up to six adjacent subswaths allows achieving ground coverage of about 200 Km in the range direction. The azimuth extension for the standard product is about 200 Km (hence envisaged for the origination of a square frame) corresponding to an acquisition of about 30.0 sec. This mode is characterized by PRF values ranges from a minimum of about 3 kHz to a maximum of about 4 kHz. Find here below an example of SCANSAR mode acquisition with the relevant characteristics briefly summarized.

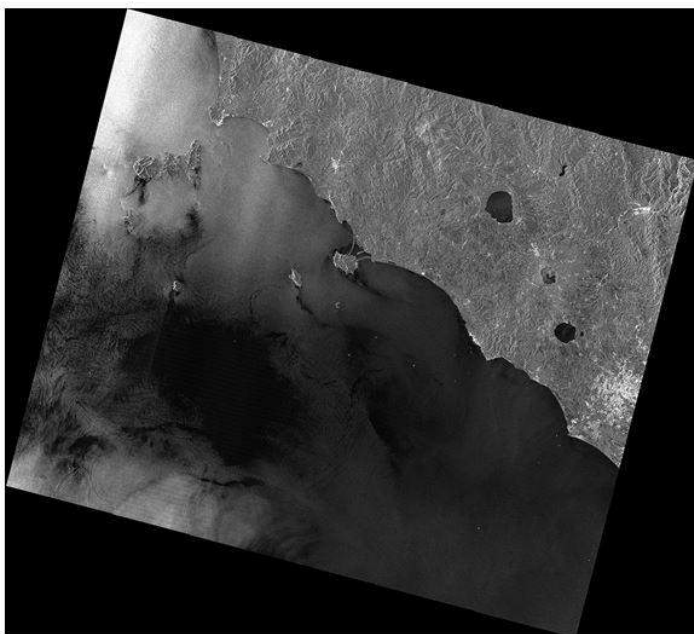

	SCANSAR WIDE	SCANSAR HUGE
Multi-look resolution (m)	30	100
Scene size (Km)	100 x 100	200 x 200
Polarization (T/R)	SINGLE, HH or HV or VH or VV	
Incidence angles (deg)	18.4 – 59.9	



Figure 6 – ScanSAR mode

2.3.2 SAR beams geometrical characteristics

The COSMO-Sky-Med SAR, as already described, supports the following imaging modes:

- SPOTLIGHT2 (ENHANCED_SPOTLIGHT)
- STRIPMAP HIMAGE
- STRIPMAP PINGPONG
- SCANSAR WIDE REGION
- SCANSAR HUGE REGION



Details of the single beams are in the following tables. Note that these beams are available both in Right-looking that in Left-looking mode. Number are given for off-nadir angles.

 	COSMO-SkyMed Mission and Products Description	Doc. N°. : ASI-CSM-PMG-NT-001 Date : 31 May 2016 Rev. : Issue 2 Pag. : 14 of 151
PROGRAMMA COSMO-SkyMed		

SPOTLIGHT-2
StripMap HIMAGE

BEAM	NEAR	FAR
ES-0A	18.170	19.970
ES-0B	19.520	20.860
ES-0C	20.600	21.940
ES-0D	21.580	22.930
ES-1	22.570	23.910
ES-2	23.730	25.070
ES-3	24.360	25.690
ES-4	25.490	26.830
ES-5	26.500	28.140
ES-6	27.980	29.080
ES-7	28.880	30.220
ES-8	30.180	31.520
ES-9	31.440	32.770
ES-10	32.310	33.650
ES-11	33.330	34.530
ES-12	34.470	35.680
ES-13	35.150	36.370
ES-14	35.930	37.240
ES-15	36.870	38.180
ES-16	38.000	39.110
ES-17	39.020	40.040
ES-18	39.970	41.090
ES-19	41.060	42.000
ES-20	41.650	42.590
ES-21	42.540	43.620
ES-22	43.570	44.400
ES-23	44.360	45.140
ES-24	45.050	45.940
ES-25	45.830	46.500
ES-26	46.460	47.130
ES-27	47.030	47.760
ES-28	47.700	48.380
ES-29	48.350	48.880
ES-30	48.860	49.410
ES-31	49.330	49.950
ES-32	49.920	50.390
ES-33	50.230	50.910
ES-34	50.790	51.300
ES-35	51.240	51.740

BEAM	NEAR	FAR
H4-0A	16.360	20.150
H4-0B	20.050	23.500
H4-1	22.600	25.660
H4-2	23.130	26.210
H4-3	25.100	28.000
H4-4	27.710	30.470
H4-5	29.270	31.960
H4-6	30.600	33.380
H4-7	32.430	34.830
H4-8	33.600	36.000
H4-9	34.600	37.200
H4-10	35.900	38.150
H4-11	37.510	39.600
H4-12	38.560	40.670
H4-13	39.340	41.390
H4-14	40.000	42.000
H4-15	41.790	43.620
H4-16	43.100	44.800
H4-17	44.490	45.920
H4-18	45.690	46.850
H4-19	46.800	47.990
H4-20	47.690	48.700
H4-21	48.640	49.800
H4-22	49.660	50.640
H4-23	50.520	51.370
H4-24	51.150	51.980

 	COSMO-SkyMed Mission and Products Description	Doc. N°. : ASI-CSM-PMG-NT-001 Date : 31 May 2016 Rev. : Issue 2 Pag. : 15 of 151
PROGRAMMA COSMO-SkyMed		

StripMap PINGPONG

BEAM	NEAR	FAR
PP-A	17.140	20.300
PP-B	20.100	22.570
PP-1	22.070	24.760
PP-2	23.550	26.230
PP-3	24.450	27.110
PP-4	26.010	28.670
PP-5	28.440	30.650
PP-6	29.850	32.050
PP-7	31.000	33.180
PP-8	32.310	34.310
PP-9	33.970	35.950
PP-10	35.440	37.330
PP-11	36.880	38.670
PP-12	37.930	39.710
PP-13	39.630	41.740
PP-14	41.700	43.280
PP-15	42.970	44.530
PP-16	44.500	45.930
PP-17	45.750	47.100
PP-18	46.810	47.980
PP-19	47.900	49.000
PP-20	48.800	49.750
PP-21	49.700	50.620
PP-22	50.490	51.360
PP-23	50.920	51.750



ScanSAR WIDEREGION

SWATH	NEAR	FAR
WR-00	16.720	28.740
WR-01	21.850	33.010
WR-02	30.120	38.670
WR-03	36.800	43.500
WR-04	40.400	45.920
WR-05	45.710	50.100
WR-06	48.020	51.370
WR-07	49.150	52.060

ScanSAR HUGEREGION

SWATH	NEAR	FAR
HG-00	16.720	33.970
HG-01	21.850	37.070
HG-02	30.120	41.880
HG-03	36.800	45.920
HG-04	43.400	50.100
HG-05	46.930	52.060

Figure 7 – COSMO-SkyMed beams

 	COSMO-SkyMed Mission and Products Description	Doc. N°. : ASI-CSM-PMG-NT-001 Date : 31 May 2016 Rev. : Issue 2 Pag. : 16 of 151
PROGRAMMA COSMO-SkyMed		

2.4 The Ground Segment

The Ground Segment is responsible for the operations and control of the entire system including the generation and dissemination of the final products. It is composed of:

- the Core ground Segment, including Satellite control facility, TT&C, Internal Communication Network, Flight Dynamics System
- Mission planning and control centre, including Mission planning facility (CPCM)
- Receiving, processing and archiving centres, including Processing and archiving facility, Satellite data receiving stations, Data exploitation, Calibration & validation, Data distribution
- Communication infrastructure including Terrestrial links
- Remote Ground Stations, including External TT&C Network, Satellite data receiving stations
- Mobile Acquisition and Processing Stations
- Fiducial Network, which provides GPS ephemeris and correction data necessary to improve precision in Precise Orbit Determination (POD)

An Integrated Logistics and Operations Segment (ILS&OPS) includes all necessary operations & logistic resources and services required for operating the space segment throughout the whole system lifetime

Following chapters describe the CPCM, the Civilian User Ground Segment (C-UGS), the Receiving Stations and the Calibration Facility, that may be of interest to Users.

2.4.1 CPCM

The so called *Centro Pianificazione e Controllo Missione* (CPCM) is the Ground Segment Element of the “Centro Gestione Sistema” (CGS) in charge of producing a conflict-free mission plan of activities for the near future time span, which achieve the user acquisition requests and optimise the system performances.

The CPCM receives the Programming Requests, at different priority levels, generated from different typologies of users at national and international levels. The CPCM evaluates the system and operative constraints in order to identify possible conflicts arising among all the Programming Requests in terms of system resource usage, including the on-board resources and constellation orbital dynamics data provided by the CGS, then archives the requests.



The CPCM provides the capabilities to generate the Mission Plan, on the basis of the Programming Requests received taking into account as input data:

- mission constraints (e.g. resource availability status),
- operative modes (routine, crisis, very urgent)
- system configuration data.

2.4.2 C-UGS

The C-UGS (Civil User Ground Segment) is the Ground Segment Element part in charge to handle, overall, the Payload Data acquires from SAR sensors, according to User Request. The main functions are:

- Interfacing the users to offer access to COSMO-SkyMed products and service (catalogue consultation, requests of products processing from data, processing of new data acquisitions, etc)
- Split User Requests in their main components and handle the relevant workflow (Acquisition,

 	COSMO-SkyMed Mission and Products Description	Doc. N° : ASI-CSM-PMG-NT-001 Date : 31 May 2016 Rev. : Issue 2 Pag. : 17 of 151
PROGRAMMA COSMO-SkyMed		

- Processing and Distribution)
- Provides requests feasibility analysis, ranking of priorities and priority harmonization among partners;
 - Receive payload data from satellite X-band downlink;
 - Receive and process support data necessary for data processing and image geo-location (e.g. from GPS ground fiducial network);
 - Perform Production Management in terms of:
 - Generation of SAR image products,
 - Cataloguing and archiving of products and raw data
 - Distribute products to users
 - Ensure Interoperability with other Partner UGS in order to export / import products, submitting and accepting requests;
 - Provide Mobile Acquisition and Processing Stations (MAPS Station).
 - Ensure expandibility and multi mission capability to cope with increased capability and/or other mission/sensors.

The only C-UGS currently operational is the Italian one (IC-UGS), that is located within the Matera Space Center.



2.4.3 Receiving Stations

All the acquisitions done by the 4 COSMO-SkyMed satellites are either downlinked in near-real-time if the acquisition is made within the visibility cone of a receiving antenna (passthrough mode) or are kept in the on-board memory and downlinked to the first available downlink station.

Currently the COSMO-SkyMed Ground Segment is composed by 3 Receiving Stations, that allow to downlink the satellites' memory in the shortest timeframe. The 3 Stations are:

- Matera, Italy
- Kiruna, Sweden
- Cordoba, Argentina

Kiru

 	COSMO-SkyMed Mission and Products Description	Doc. N° : ASI-CSM-PMG-NT-001 Date : 31 May 2016 Rev. : Issue 2 Pag. : 18 of 151
PROGRAMMA COSMO-SkyMed		

The focal point of the System Calibration Functions are the SAR Engineering Calibration Facility and the Satellite Manufacturer, which goal is to undertake the activities of Instrument characterisation, calibration, and verification with respect to:



- image quality
- instrument pointing
- data geolocation

In order to achieve these goals, the SECF functions are actually strictly coordinated with the Exploitation Functions.

The SAR Engineering Calibration Facility (SECF) (as well as the Satellite Manufacturer) is involved in the calibration operations. The first has the role to manage all the calibration operations and to monitor the image quality while the latter to implement the corrective actions eventually implied by SECF monitoring results affecting the Satellite, Payload or On Ground configurations.

The main outputs of SECF consists in:

- generation of the calibration data which is then distributed to all GS
- regular activity reports which summarise the on-board instrument performance. In case of instrument anomaly, the SECF will have the necessary investigation tools to analyse instrument data and to support the Satellite Manufacturer providing all data and information needed for the generation of the SAR Payload correction parameters (including beam mode table parameters and processing parameters)

 	COSMO-SkyMed Mission and Products Description	Doc. N°. : ASI-CSM-PMG-NT-001 Date : 31 May 2016 Rev. : Issue 2 Pag. : 19 of 151
PROGRAMMA COSMO-SkyMed		

3 System Performances

Key performances of COSMO-SkyMed are:

- Worldwide accessible area starting from the first deployed satellite, in order to acquire and furnish data on the entire earth
- Capability to acquire, during the orbital cycle, a specific site with at least 2 very different incidence angles, on the same side of the orbital plan
- Revisit time of the constellation lower than 12 hours
- Constellation average daily acquisition capability of 1800 images acquired in a 24 hours moving window (75 Spotlight plus 375 Strip or ScanSAR for each satellite)
- Constellation peak daily acquisition capability of 10 minutes of continuous operation in Stripmap or ScanSAR modes or alternatively 20 spotlight images
- Capability to deliver the image product required by the user within 72 hours (when the system is working on a H24 scenario)
- Capability to acquire interferometric image couples with a time separation of one day (tandem-like configuration)
- SAR Products suite composed by 5 “standard” products levels and 7 types of product “higher” product levels obtained by a post processing of the standard products (e.g. coregistration or speckle filtering), with a spatial resolution ranging from 1 m up to 100 m, a radiometric accuracy of 1 dB and a localization error on ground better than 15 m
- System Operational Lifetime of 15 years, with a satellite nominal lifetime of 5 year.

3.1 Archive and Product Capability

COSMO-SkyMed Data Archives and Products processing capabilities have been basically conceived and architecturally implemented as “modular” features, able to satisfy both actual Dual Use foreseen needs and future ones, thanks to the concept of *Scalability* embedded in the system architecture.

As previously described the *Scalability* concept is part of interoperability, expendability and multi mission/multi sensor (IEM) capabilities, and is based on the COSMO-SkyMed capability to vary its configuration to satisfy new needs, adding (or deleting) ‘copies’ of blocks already part of the system, and configuring it properly (e.g. adding other archiving or processing units).



On the basis of the actual envisaged Users daily needs and the relevant daily volume of payload data sensed by the entire constellation and down-linked to ground, the following raw daily data volume has been taken into account concerning the actual data archives dimensioning:

IMAGE TYPE	IC-UGS
NARROW FIELD	175
WIDE FIELD	300
TOTAL DATA VOLUME / UGS	475

Table 2 – Data Volume

The data archives have been structured in three hierarchical levels:

- On-line data (7 days)
- Near-on-line data (6 months)

 	COSMO-SkyMed Mission and Products Description	Doc. N°. : ASI-CSM-PMG-NT-001 Date : 31 May 2016 Rev. : Issue 2 Pag. : 20 of 151
PROGRAMMA COSMO-SkyMed		

- Off-line data (15 years)

The System daily products number at IC-UGS is 200 for levels 1C/1D, higher for lower product levels.

Any future needs shall be satisfied by the embedded scalability of the system, upgrading both data archives and processing chains as required by the User needs.

3.2 Time Performances

Three different System operative modes have been defined (called routine, crisis and very urgent) allowing to respond to different needs in term of required programming latency.

- In the first mode (routine) the requests of the users pertaining image acquisitions are planned and sent to the constellation once a day.
- In the second mode (crisis) this operation is done twice a day.
- The third mode (very urgent) is asynchronous, allowing the servicing of an image acquisition request with the minimum possible latency.

The system is capable to satisfy a User Request (ability to deliver the image product required by an End User in a timely manner) which in the case of the first level of SAR standard products (not derived from spotlight mode acquisitions) is within 72 hours for the system working in routine mode (acquisition plan uploaded once a day), 36 hours for the crisis mode (acquisition plan uploaded twice a day) and 18 hours for very urgent mode (acquisition plan uploaded asynchronously).

Only the Italian Government Authorities are in charge to require a change of System Modes (i.e. Routine, Crisis, and Very Urgent) or to require specific services, such as the imposition of veto on the acquisition over specific areas.

More in general, the time performances of the constellation are defined on the basis of the following four definitions:



- reaction time: time span from the User request acceptance and Deposit at the IC-UGS to the SAR image acquisition;
- information age: from the SAR image acquisition to the product availability at the IC-UGS (data latency);
- response time: is the sum of the reaction time and the information age;
- revisit time: time span between two consecutive acquisitions over the same target.

The delivery time is not considered in the Response Time.

Following table reports the values to be considered for the above times (values are referred to routine operative conditions):

	1 satellite	2 satellites	3 satellites	Full constellation
Information age	12 h	12 h	12 h	12 h
Response Time	110 h	90 h	85 h	72 h
Revisit time	65 h	40 h	35 h	12 h



Table 3 – Timing performances of the COSMO-SkyMed constellation

 	COSMO-SkyMed Mission and Products Description	Doc. N°. : ASI-CSM-PMG-NT-001 Date : 31 May 2016 Rev. : Issue 2 Pag. : 21 of 151
PROGRAMMA COSMO-SkyMed		

Please note that these values refer to routine (nominal) operational status, and that they are worst case foreseen values on the overall globe, while actual values depend upon site coordinates, active ground segment, constellation configuration, operational mode etc.

As an example the values of the Revisit Time are reported in the next table in the 90% of the cases:

	1 satellite	2 satellites	3 satellites	Full constellation
Revisit time	24 h	13 h	12 h	11 h

 	COSMO-SkyMed Mission and Products Description	Doc. N°. : ASI-CSM-PMG-NT-001 Date : 31 May 2016 Rev. : Issue 2 Pag. : 22 of 151
PROGRAMMA COSMO-SkyMed		

4 COSMO-SkyMed SAR Products Overview

This chapter, after a brief summary of the COSMO-SkyMed SAR Imaging Modes, describes the three major classes of COSMO-SkyMed SAR products and the related products tree.

4.1 The COSMO-SkyMed SAR imaging Modes

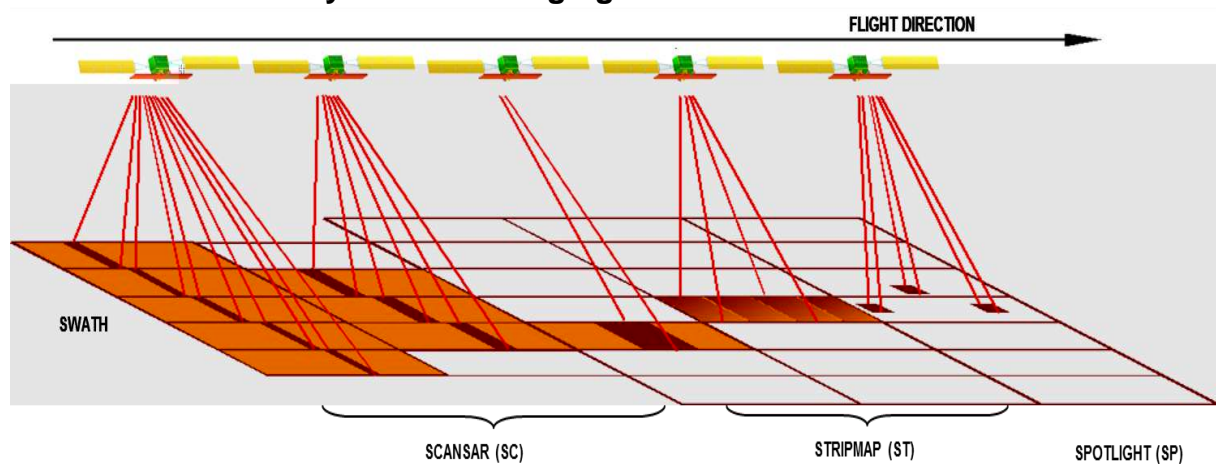

Figure 8 – COSMO SAR Acquisition Modes

The COSMO-SkyMed SAR instrument can be operated in different beam which include:



- SPOTLIGHT (mode 2 and mode 1) (Note: mode 1 is for Defence use only and is not further described)
- STRIPMAP (HIMAGE and PINGPONG)
- SCANSAR (WIDE REGION or HUGE REGION)

The characteristics of SAR measurement modes are briefly delineated hereafter:

- SPOTLIGHT, allowing SAR images with spot extension of $10 \times 10 \text{ km}^2$ and spatial resolution equal to 1 m (Spotlight-2);
- STRIPMAP HIMAGE, achieving medium resolution, with 40 km swath extension and a spatial resolution of 3 m single look (5 m multi look);
- STRIPMAP PINGPONG, achieving medium resolution, with two radar polarization's selectable among HH/VV, HH/HV, or VV/VH, a spatial resolution of 20 meters on a 30 km swath;
- SCANSAR WIDE and HUGE REGION, achieving lower resolution radar imaging with large swath extension selectable from 100 km (WIDE REGION) to 200 km (HUGE REGION), and a spatial resolution selectable from 30 m to 100 m (in both cases multi-looked)

The common quality parameters of all the SAR products are:

- PSLR -22 dB
- ISLR -12 dB
- Azimuth Point Target Ambiguity -40 dB

 	COSMO-SkyMed Mission and Products Description	Doc. N°. : ASI-CSM-PMG-NT-001 Date : 31 May 2016 Rev. : Issue 2 Pag. : 23 of 151
PROGRAMMA COSMO-SkyMed		

- Radiom. Accuracy -1 dB (single look)
- Radiom. Linearity -1.5 dB
- Radiom. Stability -1 dB
- Total NESZ -21/-22 dB2/m2

The COSMO-SkyMed products are generated only after the availability of the filtered orbital information (ORB_F), which generally is after 5-6 hours from sensing. In case there is the need to produce the product as soon as possible without waiting for the filtered orbital information (and therefore having products with a geolocation accuracy which may be out of specifications), there is the possibility to ask for a Fast Delivery option.

The accuracy of the orbital information (derived from the ORB_F files) that is delivered with the COSMO products is better than 1 meter.

4.2 The major classes of COSMO SAR products

The COSMO-SkyMed products are divided in the following major classes:

- Standard products
- Higher level products
- Auxiliary products (for internal use only)

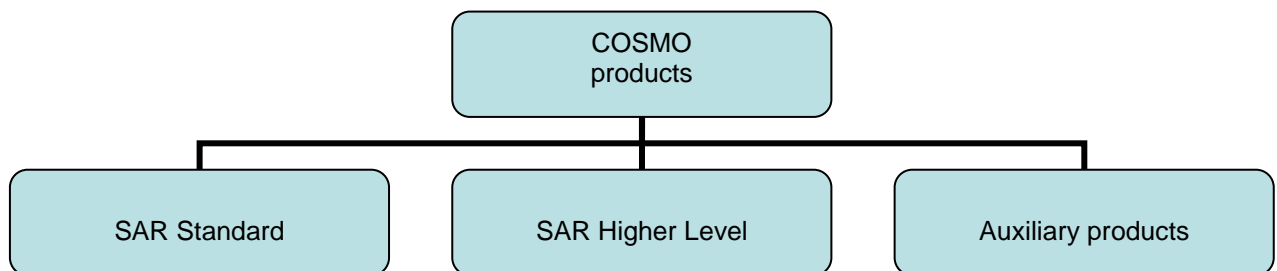



Figure 9 – The 3 classes of COSMO-SkyMed products

The SAR Standard products are the basic image products of the system, are suitable for many remote sensing applications based on direct usage of low level products and are subdivided into 4 typologies, coded as:

- Level 0 RAW data, defined as “on board raw data (after decryption and before unpacking) associated with auxiliary data including calibration data required to produce higher level products”. This data consists of time ordered echo data, obtained after decryption and decompression (i.e. conversion from BAQ encoded data to 8-bit uniformly quantised data) and after applying internal calibration and error compensation; it include all the auxiliary data (e.g.: trajectography, accurately dated satellite’s co-ordinates and speed vector, geometric sensor model, payload status, calibration data,..) required to produce the other basic and intermediate products.
- 1A, Single-look Complex Slant product, RAW data focused in slant range-azimuth projection, that is the sensor natural acquisition projection; product contains In-Phase and Quadrature of the focused data, weighted and radiometrically equalized
- 1B, Detected Ground Multi-look product, obtained detecting, multi-looking and projecting the

 	COSMO-SkyMed Mission and Products Description	Doc. N°. : ASI-CSM-PMG-NT-001 Date : 31 May 2016 Rev. : Issue 2 Pag. : 24 of 151
PROGRAMMA COSMO-SkyMed		

Single-look Complex Slant data onto a grid regular in ground; Note: Spotlight Mode products are not multilooked

- 1C/1D, Geocoded product GEC (1C level product) and GTC (1D level product), obtained projecting the 1A product onto a regular grid in a chosen cartographic reference system. In case of Lev 1C the surface is the earth ellipsoid while for the Lev 1D a DEM (Digital Elevation Model) is used to approximate the real earth surface. The DEM currently used in the COSMO-SkyMed system is the SRTM with 90 m posting, therefore the level 1D products are available only within the latitudes of 61° North and 56° South.

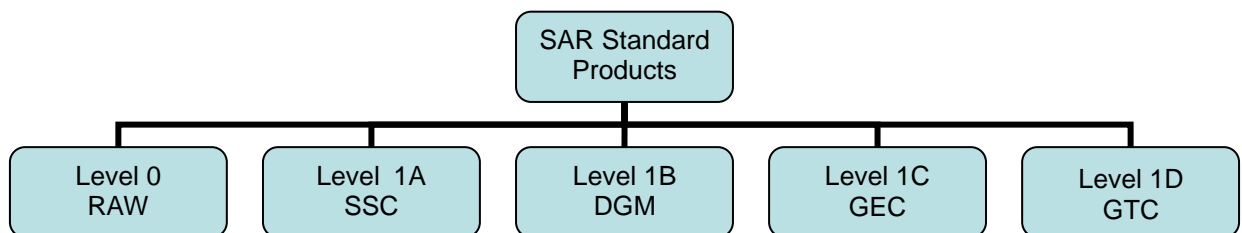

Figure 10 – The 5 types of COSMO-SkyMed SAR Standard Products

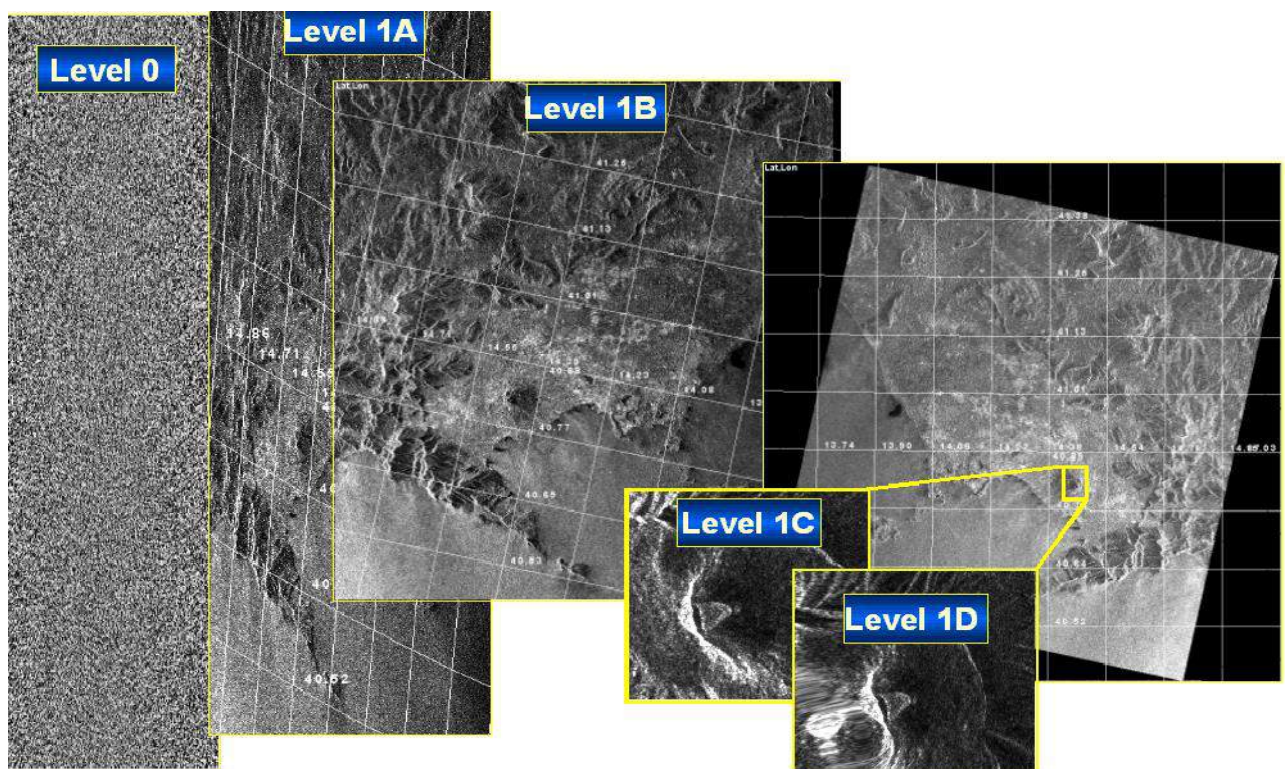



Figure 11 – The 5 types of COSMO-SkyMed Standard Products

 	COSMO-SkyMed Mission and Products Description	Doc. N°. : ASI-CSM-PMG-NT-001 Date : 31 May 2016 Rev. : Issue 2 Pag. : 25 of 151
PROGRAMMA COSMO-SkyMed		

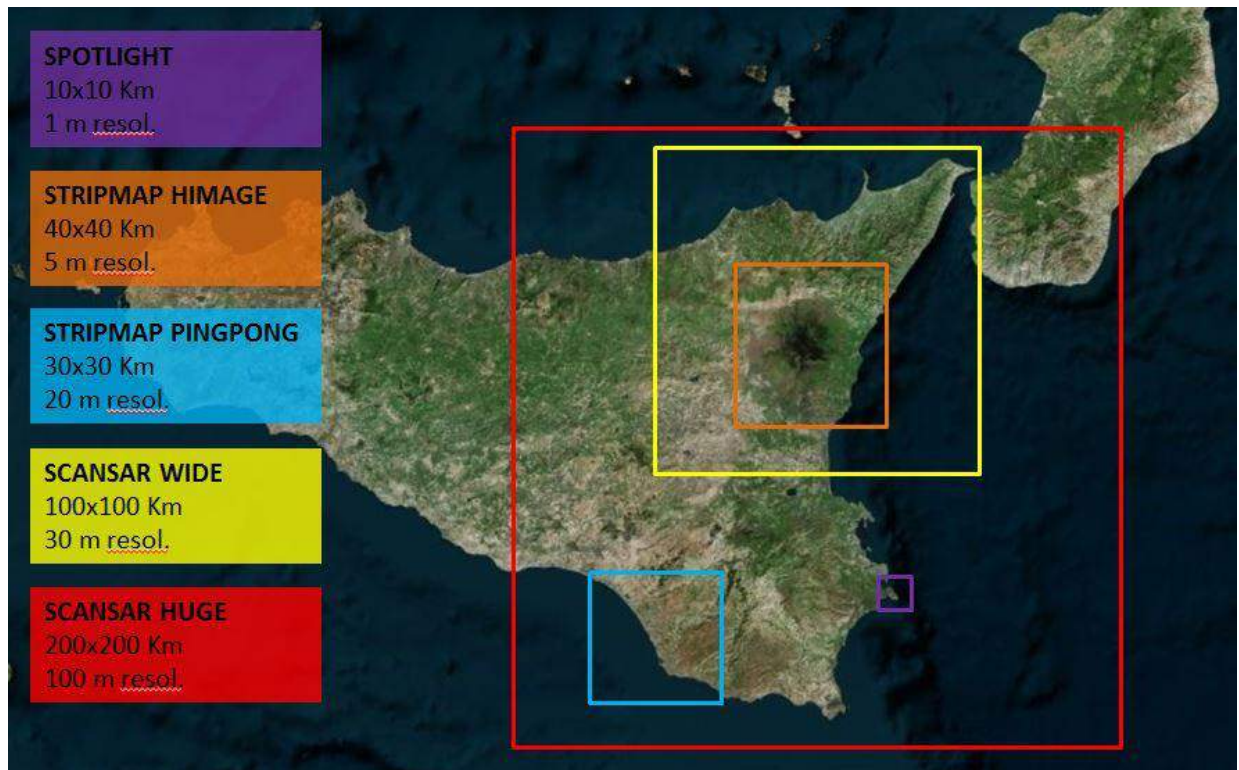



Figure 12 – A pictorial view of the 5 major types of COSMO-SkyMed Acquisition Modes

The SAR Higher Level products, suited for mid or even high level remote sensing applications, are composed by the following products:

- Quicklook, reduced spatial resolution image for browsing purposes
- Co-registered products, a set of image layers coregistered together (i.e. merged in vertical direction), for interferometry, change detection and so on
- Mosaiked products, a set of image joined together (i.e. merged in horizontal direction), for large spatial coverage representation
- Speckle filtered image, an image with an increased equivalent number of looks (ENL)
- Interferometric products (interferometric coherence and phase), in support of the interferometric applications
- DEM, Digital elevation data and related height error map obtained with interferometric techniques

 	COSMO-SkyMed Mission and Products Description	Doc. N°. : ASI-CSM-PMG-NT-001 Date : 31 May 2016 Rev. : Issue 2 Pag. : 26 of 151
PROGRAMMA COSMO-SkyMed		

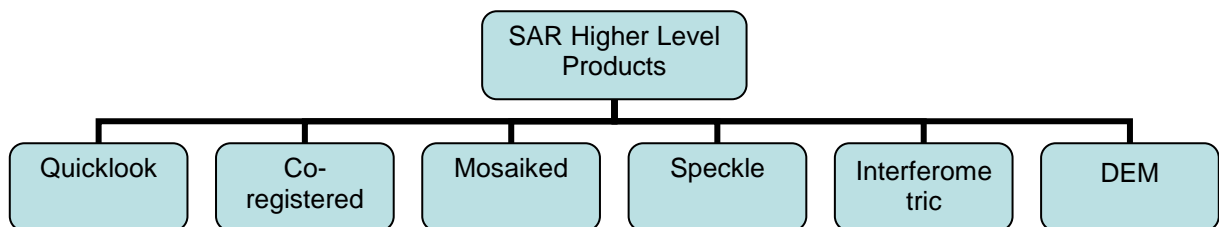

Figure 13 – The 6 types of COSMO-SkyMed SAR Higher Level Products

Service products are used internally either like auxiliary data for production chain or like further analysis performed on all products delineated above. Such product are basically constituted by the Orbital product and the Quality Control product.

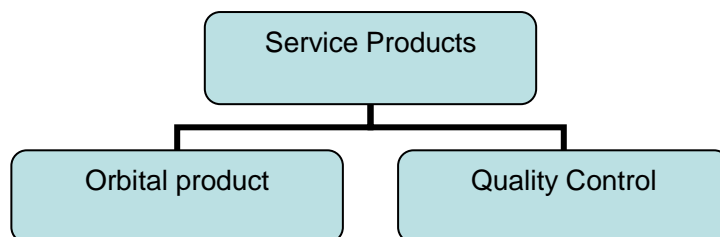



Figure 14 – The 2 types of COSMO-SkyMed Service Products

 	COSMO-SkyMed Mission and Products Description	Doc. N°. : ASI-CSM-PMG-NT-001 Date : 31 May 2016 Rev. : Issue 2 Pag. : 27 of 151
PROGRAMMA COSMO-SkyMed		

5 Products Description

The COSMO-SkyMed products are divided in the following major classes and briefly described in next sections:

- Standard products
- Higher level products
- Service products (for internal use only)

5.1 Standards Products

The foreseen standard processing levels (from level 0 up to 1D) are compliant with the definitions given in international standards for Earth Observation (e.g. CEOS guidelines). A further categorization defines the standard processing through three successive stages:

- Pre-processing
- Processing
- Image geo-localization



Pre-processing stage involves the operations that are normally required prior to the main data analysis and extraction of information (i.e. Level 0 processing). Processing stage mainly performs radiometric and geometric corrections of the imagery (i.e. Level 1A and Level 1B processing). The last thread of this elaboration chain is the projection of the imagery on known reference system (i.e. Level 1C and Level 1D processing).

The following standard processing levels are conceived for COSMO:

- **Level 0 (RAW)**, containing for each sensor acquisition mode the unpacked echo data in complex in-phase and quadrature signal (I and Q) format. The processing performed on the down linked X-band raw signal data are:
 - frame synchronization
 - transmission protocol removal
 - packet data filed re-assembly
 - data decompression
 - statistics estimation
 - data formatting
- **Level 1A products (SCS)**, whose processing is aimed at generating Single-look Complex Slant (SCS) products. The SCS product, obtained after the L1A processing, contains focused data in complex format, in slant range and zero Doppler projection. The processing performed on L0 input data are:
 - gain receiver compensation
 - internal calibration
 - data focusing
 - statistics estimation of the output data
 - data formatting into output

Level 1A products are available as Balanced (SCS_B) or Unbalanced (SCS_U).

The Un-balanced product (SCS_U) gives, with an approach as much conservative as possible, the focused representation of the raw signal echoed by the observed scene; the product is mainly conceived as a starting point for higher processing level production. The product is in complex format, slant and zero Doppler projection.

 	COSMO-SkyMed Mission and Products Description	Doc. N°. : ASI-CSM-PMG-NT-001 Date : 31 May 2016 Rev. : Issue 2 Pag. : 28 of 151
PROGRAMMA COSMO-SkyMed		

Therefore no radiometric equalization (in terms of compensation of the range antenna pattern and incidence angle) is performed (only compensation of the antenna transmitter gain and receiver attenuation and range spreading loss is applied).



In addition an un-weighted processing is performed, that is no windowing is applied on the processed bandwidth

The Balanced product (SCS_B) contains for each sensor acquisition mode the focused data in complex format, in slant range and zero doppler projection.

In addition to compensations, internal calibration and data focussing, the following processing steps are applied:

- Weighted processing is performed with application of cosine-like windowing
- Radiometric equalization of the complex image in terms of:
 - compensation of the range spreading loss
 - rescaling with respect to a reference slant range in order to not alter the dynamic of the output product
 - compensation of the range antenna pattern, with off-nadir angles estimated on the ellipsoid in the acquisition geometry
 - compensation of the incidence angle estimated on the ellipsoid in the acquisition geometry
 - rescaling with respect to a reference incidence angle in order to not alter the dynamic of the output product
- **Level 1B Products (DGM)**, whose processing is aimed at generating Detected Ground Multi-look (MDG) products, starting from input (L1A) data. A MDG product, obtained after L1B processing, contains focused data, detected, radiometrically equalized and in ground range/azimuth projection. The processing performed on L1A input data are:
 - multi-looking for speckle reduction
 - image detection (amplitude)
 - ellipsoid ground projection
 - statistics evaluation
 - data formatting
- **Level 1C Products (GEC)**, whose processing is aimed at generating Geocoded Ellipsoid Corrected (GEC) products. A GEC product, obtained after L1C processing, contains focused data, detected geo-located on the reference ellipsoid and represented in a uniform pre-selected cartographic presentation. The processing performed on L1B input data are:
 - multi-looking for speckle reduction
 - ellipsoid map projection
 - statistics evaluation
 - data formatting
- **Level 1D Products (GTC)**, whose processing is aimed at generating Geocoded Terrain Corrected (GTC) products. A GTC product, obtained after L1D processing, contains focused data projected onto a reference elevation surface in a regular grid obtained from a cartographic reference system. The image scene is located and accurately (x, y, z) rectified onto a map projection, through the use of Ground Control Points (GCPs) and Digital Elevation Model (DEM). The processing performed on L1B input data is actually similar to GEC processing but for the use of the DEM for the accurate conversion from slant to ground range.

The standard processing model is shown in the following figure:

 	COSMO-SkyMed Mission and Products Description	Doc. N°. : ASI-CSM-PMG-NT-001 Date : 31 May 2016 Rev. : Issue 2 Pag. : 29 of 151
PROGRAMMA COSMO-SkyMed		

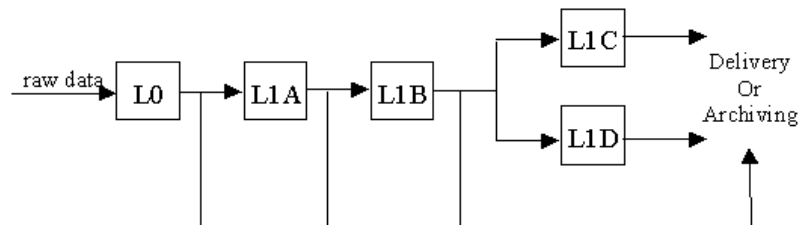

Figure 15 – Standard Processing Model

This model is valid for the different SAR measurement modes (Spotlight, Stripmap, ScanSAR), whilst the level processor is different for each product type.



In the following section the main specific characteristics of the products are shown (Size and Geometrical resolution), along with the related sensor configuration (Swath and Incidence angle), for product acquired in Civilian sensor modes.

A common characteristics of all standard products is the value of the geolocation accuracy, which originally has been designed as:

- an error of less than 25 m (20 m goal) with respect to the WGS84 reference ellipsoid (without ground control points or DEM) 3-sigma with respect to the WGS84 reference ellipsoid
- an error of less than 15 m with DEM

5.1.1 COSMO-SkyMed Product Detail

In the following table there are the initial design specifications of the different imaging modes and the 4 processing levels.



 agenzia spaziale italiana 	COSMO-SkyMed Mission and Products Description	Doc. N° : ASI-CSM-PMG-NT-001 Date : 31 May 2016 Rev. : Issue 2 Pag. : 30 of 151
PROGRAMMA COSMO-SkyMed		

Acquisition Mode	Processing levels:	Level 1A (SCS)	Level 1B (DGM)	Level 1C (GEC)	Level 1D (GTC)
Spotlight-2	Range resolution (m)	1.1 ÷ 0.9	1	1	1
	Azimuth resolution (m)	0.91	1	1	1
	Swath width (km)	10			
	Scene length (km)	10			
	Scene duration (sec)	7			
	Geolocation accuracy 3 sigma (m)	N/A	< 25	< 25	< 15
	Number of looks	N/A	1	1	1
STRIPMAP HIMAGE	Range resolution (m)	3 ÷ 2.6	5	5	5
	Azimuth resolution (m)	2.4 - 2.6	5	5	5
	Swath width (km)	40			
	Scene length (km)	40			
	Scene duration (sec)	7			
	Geolocation accuracy 3 sigma (m)	N/A	< 25	< 25	< 15
	Number of looks	N/A	~ 3	~ 3	~ 3
STRIPMAP PING PONG	Range resolution (m)	11 ÷ 10	20	20	20
	Azimuth resolution (m)	9.7	20	20	20
	Swath width (km)	30			
	Scene length (km)	30			
	Scene duration (sec)	6			
	Geolocation accuracy 3 sigma (m)	N/A	< 25	< 25	< 15
	Number of looks	N/A	~ 3	~ 3	~ 3
SCANSAR WIDE REGION	Range resolution (m)	13.5	30	30	30
	Azimuth resolution (m)	23.0	30	30	30
	Swath width (km)	100 - 160			
	Scene length (km)	100			
	Scene duration (sec)	15			
	Geolocation accuracy 3 sigma (m)	N/A	< 30	< 30	< 30
	Number of looks	N/A	~ 4 - 9	~ 4 - 9	~ 4 - 9
SCANSAR HUGE REGION	Range resolution (m)	13.5	100	100	100
	Azimuth resolution (m)	38.0	100	100	100
	Swath width (km)	170 - 240			
	Scene length (km)	200			
	Scene duration (sec)	30			
	Geolocation accuracy 3 sigma (m)	N/A	< 100	< 100	< 100
	Number of looks	N/A	~ 25 - 66	~ 25 - 66	~ 25 - 66

Table 4 – COSMO-SkyMed product details

5.1.2 COSMO-SkyMed Standard Products current performances

The performances of the COSMO-SkyMed satellites, instruments and products are continuously monitored, measured and compared with the system specifications. The COSMO-SkyMed system is



 	COSMO-SkyMed Mission and Products Description	Doc. N°. : ASI-CSM-PMG-NT-001 Date : 31 May 2016 Rev. : Issue 2 Pag. : 31 of 151
PROGRAMMA COSMO-SkyMed		

even exceeding the system specifications in some domains, as demonstrated during the calibration and validation campaigns.

For what concerns the geolocation accuracy of the 1C products (as measured over specific calibration sites, equipped with specific corner reflectors), the measurements done by Thales Alenia Space Italia and reported in the document “Products Certification/Validation Dossier” (RPT-CSM-1613-ALS ISSUE 23), report the values in the following table.

Imaging mode		Spotlight-2	StripMap HIMAGE	StripMap PING PONG	ScanSAR Wide	ScanSAR Huge
Number of image samples		17	71	25	14	13
Average Linear Error (ALE)	Mean [m]	1.73	6.00	3.97	4.52	3.95
	Dev. Std. [m]	1.26	1.73	3.48	1.57	0.82
	Max [m]	4.84	9.45	10.26	5.95	4.61
	Min [m]	0.45	2.40	0.55	1.04	2.26
Geolocation error (3-sigma) [m]		5.51	11.19	14.41	9.23	6.41

Table 5 – Measured geolocation accuracy of Level 1C products

 	COSMO-SkyMed Mission and Products Description	Doc. N°. : ASI-CSM-PMG-NT-001 Date : 31 May 2016 Rev. : Issue 2 Pag. : 32 of 151
PROGRAMMA COSMO-SkyMed		

5.2 Higher Level Products

Higher Level Product include the following types briefly summarized hereafter:

- Quick-Look Products
- Speckle Filtered Products
- Co-registered Products
- Interferometric Products
- Digital Elevation Model (DEM) Products
- Mosaicked Products

Two further products exists, but since they are envisaged for Defence Users only, are here only listed and not further described:

- Products for Band Reduction
- Defence Applications product



5.2.1 Quick Look Products

These products are synoptic of the entire datum allowing a look to the image content in a faster way than the one obtained by processing the image according to the standard algorithms. It is an image easy to visualize: this image shall be easily opened and viewed with conventional image software and self-explanatory from the geo-location point of view. The main characteristics of the Quicklook produc are:

- the product is detected
- the product it's ground projected
- the product has integer pixels with values scaled in the range 0 - 255
- depending by the look side and orbit pass, the order of the columns or lines within the image is reversed (with respect the level 0 data) in order present the image in the closest way respect a map
- the product has curves (iso-latitude and iso-longitude) which allow the visualization of the geographic coordinates within the image

The Quick Look Products have a degraded processing bandwidth and so the resolution is consequently scaled. The characteristics of the product in terms of geometric resolution and geometric accuracy are however specified and kept under control, in order to allow the usage of this product (whose primary scope is the image browsing) even in remote sensing applications. In the following table the Quick Look Products characteristics of resolution and geometric accuracy are summarized.

	SPOTLIGHT	STRIPMAP HIMAGE	STRIPMAP PINGPONG	SCANSAR WIDE REGION	SCANSAR HUGE REGION
Product Size [MB]	17	20÷30	4÷7	8÷15	4÷7
Ground Range resolution [m]	≤ 50	≤ 100	≤ 200	≤ 300	≤ 600
Azimuth resolution [m]	≤ 50	≤ 100	≤ 200	≤ 300	≤ 600
Equivalent Number of looks	≥ 10	≥ 10	≥ 10	≥ 10	≥ 10
Geometric accuracy [m] Case of high quality GPS data (Selective Availability OFF)	≤ 50	≤ 60	≤ 100	≤ 150	≤ 300

 	COSMO-SkyMed Mission and Products Description	Doc. N°. : ASI-CSM-PMG-NT-001 Date : 31 May 2016 Rev. : Issue 2 Pag. : 33 of 151
PROGRAMMA COSMO-SkyMed		

Geometric accuracy [m] Case of low quality GPS data (Selective Availability ON)	≤ 150	≤ 150	≤ 150		
---	-------	-------	-------	--	--

Table 6

5.2.2 Speckle Filtered Products

The Higher Level Speckle Filtered Product deals with the improvement of the radiometric resolution of the SAR images by means of the reduction of the intrinsic multiplicative-like speckle noise. Speckle is a multiplicative noise-like characteristic of coherent imaging systems (such as the SAR), which manifests itself in the image as the apparently random placement of pixels which are noticeably bright or dark. In fact the speckle is a real electromagnetic effect that originates from the constructive or destructive interference (within a resolution cell) of multiple returns of coherent electromagnetic radiation. The COSMO SkyMed SAR Standard Products described above, provide speckle reduction via multi-looking, which may be not suitable for all potential high-level applications of the COSMO data: classification, feature extraction, change analysis and detection, soil parameters estimations. For that fact, the Speckle Filtering processor tries to cope with any generic application that could benefit of a speckle noise suppression, improving the radiometric resolution of the SAR Standard images thus allowing a better estimation of the radiometric quantities and minimizing, whenever possible, side effects (degradation of the spatial resolution, artefacts, feature alteration). As such, the Speckle Filtered Product is derived by post-processing of the SAR Standard Level 1A or 1B products. The filtered product is formally equivalent to a 1B standard product and may be further processed by the SAR Standard chain. Many types of filters are allowable, belonging to various classes (Non-Adaptive, Adaptive MMSE, Adaptive MAP, Morphological). Speckle filtered products can be generated starting from level 1B products and hence originating a product at same level. The expected increase in the Equivalent Number of Looks for the various allowable filters is shown in next table.

Filter	Equivalent number of looks increasing factors
Mean	≥ 4.1
Median	≥ 3.0
Lee	≥ 4.1
Enhanced Lee (dumping factor = 0.5)	≥ 4.1
Kuan	≥ 4.1
Frost (dumping factor = 0.5)	≥ 2.9
Enhanced Frost (dumping factor = 0.5)	≥ 4.1
Gamma MAP	≥ 3.7
Crimmins (iteration = 8)	≥ 1.3

Table 7

The following table shows the geometric resolution of the speckle filtered products obtained applying a filter having a kernel size of 5 x 5 to 1B products, in the various acquisition modes. Note that the 1B speckle filtered product can be used for the geocoded (Lev 1C-1D) products generation, hence originating speckle filtered geocoded products.

 	COSMO-SkyMed Mission and Products Description	Doc. N°. : ASI-CSM-PMG-NT-001 Date : 31 May 2016 Rev. : Issue 2 Pag. : 34 of 151
---	--	---

PROGRAMMA COSMO-SkyMed

	SPOTLIGHT	STRIPMAP HIMAGE	STRIPMAP PINGPONG	SCANSAR WIDE REGION	SCANSAR HUGE REGION
Product Size [MB]	same as input				
Ground Range resolution [m]	≤ 4.5	≤ 25.0	≤ 90.0	≤ 140.0	≤ 460.0
Azimuth resolution [m]					

Table 8

5.2.3 Co-registered Products



Two different images covering the same area can be made superimposable by means of the co-registration which is the process of lining-up two images, one “master” and the other one is the “slave” image, such to fit exactly on top of each other without adding artifacts in image intensity and phase components. The input images are co-registered using the master as reference. Co-registered images can be taken from simultaneous illuminations of the same scene at different frequencies (multi frequency images), from acquisitions taken at different time using different sensors, from multiple passages of the same satellite (multi temporal images). In general, images have different geometry, thus to be superposed the slave image must be re-sampled into the master geometry. The images may be fully or only partly overlapped and even more than two images can be co-registered at the same time. The co-registration process generates as many output images as the input are: one master image and multiple slave images in input give one co-registered master image and the multiple co-registered slave images. The type of the images is preserved: input real or complex images produce output real or complex co-registered images respectively. As such, the higher level Co-registration products are derived in any acquisition mode, by post-processing of the SAR Level 1A (complex images) or level 1B (real images) SAR standard products, respectively generating a product complex or real (co-registered product). Co-registered products can be further processed by the SAR standard processing chain. The coregistration of two generic image products acquired by one or many satellites, cannot be done in every acquisition condition but is subject to some constraints. Few examples of such constraints are:

- images shall be acquired with the same instrument mode
- images shall be acquired with the same look side and orbit directions
- in case of 1A products, images shall be acquired with the same subswath (i.e. having the same Beam)

The main performance of the coregistered product is the coregistration accuracy (expressed in pixel units) which is shown in next table.

 	COSMO-SkyMed Mission and Products Description	Doc. N°. : ASI-CSM-PMG-NT-001 Date : 31 May 2016 Rev. : Issue 2 Pag. : 35 of 151
PROGRAMMA COSMO-SkyMed		



 	COSMO-SkyMed Mission and Products Description	Doc. N°. : ASI-CSM-PMG-NT-001 Date : 31 May 2016 Rev. : Issue 2 Pag. : 36 of 151
PROGRAMMA COSMO-SkyMed		

In the cases 3 and 4, mosaicking among scenes that could be characterized by different orientation angles is requested; in such case, after having identified the master tile (the azimuth and range directions of the output mosaick must be referred to), slave tiles are at first regridded on the same grid of the master one by a very coarse approach based on correlation to the master orbit and a warp model derivation and application; such approach will be allowed only supposing that input tiles had been processed with orbital data derived from POD facility (hence, not processed with state vectors embedded into the downlinked RAW data). Finally, the mosaicking process is completed applying feathering on the overlapping zones. However, feathering is a configurable parameter of the Processing Request File and can be turned off during the CalVal activities.

In the case of mosaicking of GTC, only the SAR image is included into the output product, that is the GIM layer is not mosaicked. In the case of mosaicking of DTM, The mosaicked HEM is also included into the output product.

The following table shows the mosaiked product main characteristics in case of 1B,1C,1D products.

	SPOTLIGHT	STRIPMAP HIMAGE	STRIPMAP PINGPONG	SCANSAR WIDE REGION	SCANSAR HUGE REGION
Product Size [MB]	~ 3200	~28800	~3600	~800	~128
Maximum Coverage [km ²]	20 x 20	300 x 300	300x 300	300x 300	400x 400
Ground Range resolution [m]	as input				
Azimuth resolution [m]					

Table 10



The following table shows the mosaiked product main characteristics in case of DEM products.

	SPOTLIGHT	STRIPMAP HIMAGE	SCANSAR WIDE REGION	SCANSAR HUGE REGION
Product Size [MB]	~ 355	~7200	~800	~128
Maximum Coverage [km ²]	20 x 20	300 x 300	300x 300	400x 400

Table 11

5.2.5 Interferometric Products

Synthetic Aperture Radar interferometry is an imaging technique for measuring the topography of the surface and its changes over time. A radar interferometer is formed relating the signals from two spatially separated antennas; the separation of the two antennas is called baseline. COSMO-SkyMed constellation can be used for interferometric applications, which allow to produce three-dimensional SAR images by combining two radar images of the same point on the ground (one “master” and the other one is the “slave” image) obtained from slightly different incidence angles. COSMO-SkyMed constellation offers two different possibilities to achieve the interferometric baseline, namely: (1) the

 	COSMO-SkyMed Mission and Products Description	Doc. N°. : ASI-CSM-PMG-NT-001 Date : 31 May 2016 Rev. : Issue 2 Pag. : 37 of 151
PROGRAMMA COSMO-SkyMed		

“tandem-like” interferometry configuration (i.e. “one-day” of relative phasing between the satellite couple), and (2) the “tandem” interferometry configuration (i.e. two satellites flying in close proximity). As such, the Interferometric products are derived by processing SAR Level 1A co-registered data, taken in any acquisition mode (except Polarimetric), to generate in automatic way the following product classes:

- Wrapped interferometric phase (and the annexed layer including demodulation phase estimated on flat terrain) of two coregistered SAR images of Level 1A
- the coherence map

Some constraints exists in the generation of the interferometric products. As examples cannot be used as inputs:

- polarimetric products or products having different transmit-receive polarizations
- products acquired on different subswaths or different look side or orbit direction

The interferometric products maintain the same geometry of the input 1A prioducts and hence are in a slant range/azimuth projection. Spacing features of the interferometric products are inherited from the co-registered input images couple but due to interferometric multilooking, spacing and corresponding size is reduced according to the following table:

	SPOTLIGHT	STRIPMAP HIMAGE	SCANSAR WIDE REGION	SCANSAR HUGE REGION
Range reduction factor	3	4	6	6
Azimuth reduction factor	4	5	3	5

Table 12



5.2.6 DEM Products

The Digital Elevation Model (DEM) products are derived by mean interferometric processing of the SAR Level 1A coregistered products, in any acquisition mode except Polarimetric, in automatic way. DEM products consist of the ellipsoidal height map and the associated height error map. The attributes defining the DEM products are derived from the SAR image couple, with some substantial changes (e.g. due to the change of the image projection). The DEM product is presented in UTM/UPS cartographic coordinate system respect to WGS84 ellipsoid, different from the input geometry (slant-range). The product is composed by:

- ellipsoidal height map
- associated height error map

The attributes defining the DEM products are derived from the SAR image couple, with some substantial changes (e.g. due to the change of the image projection). The DEM product is presented in UTM/UPS cartographic coordinate system respect to WGS84 ellipsoid, hence different from the input geometry (slant-range). In the case of DEM product originated from ScanSAR interferometric couple, output is presented in a single layer having elementary beams mosaicked in the range direction. The same constraints already shown for interferometric product also exists in the generation of the DEM products. The DEM and Error map are represented in the same geometry, with the same pixel spacing and have the same size. The main characteristics of the DEM is the height accuracy, the horizontal accuracy and the posting (shown in next tables). The accuracies are strongly dependent by the coherence value and by the geometric configuration of the acquisition and scene, as well as the quality of the input ground control points used during the geometric calibration. For this reason the tables show two groups of performances:

- Relative accuracies: errors in absence of any calibration, true height not known

 	COSMO-SkyMed Mission and Products Description	Doc. N°. : ASI-CSM-PMG-NT-001 Date : 31 May 2016 Rev. : Issue 2 Pag. : 38 of 151
PROGRAMMA COSMO-SkyMed		

- Absolute accuracies: true errors within specified Baseline, Incidence angle, terrain slope, availability of Ground Control Points.

Symbols Explanation: B^{\perp} = Value of orthogonal baselines, ϑ =incidence angle, α =Maximum terrain slope for the 95% of point of the projected region

Relative accuracies	SPOTLIGHT	STRIPMAP HIMAGE	SCANSAR WIDE REGION	SCANSAR HUGE REGION
	$B^{\perp} = 100 \div 3500$ (granted with an accuracy of 20%) Coherence ≥ 0.8			
Relative height accuracy[m]	≤ 3.8	≤ 6.9	≤ 17.1	≤ 76
Relative horizontal accuracy [m]	≤ 2.9	≤ 4.5	≤ 9.4	≤ 32.8

Table 13

Absolute accuracies	SPOTLIGHT	STRIPMAP HIMAGE	SCANSAR WIDE REGION	SCANSAR HUGE REGION
	$B^{\perp} = 400 \div 600$ $50^{\circ} < \vartheta < 60^{\circ}$ $\alpha \leq 30^{\circ}$			
Absolute height accuracy[m]	≤ 34.6	≤ 36.3	≤ 45.2	≤ 174.8
Absolute horizontal accuracy [m]	≤ 30.7	≤ 30.9	≤ 31.3	≤ 101.4
Posting [m x m]	3x3	10x10	30x30	90x90

Table 14



5.2.7 Distribution Media

Besides the digital format of the products, the following media types will be used for non-electronic product distribution: DVD, CDROM, Magnetic cassette. Electronic distribution will be based on a FTP access to the COSMO site (FTP “get” from the ICUGS FTP server, or FTP “put” on a FTP server provided by the customer, as requested by the user).



5.3 Service Products

The Service Products (only foreseen for internal use) are:

- Orbital product: necessary to perform SAR images geo-location. These products are qualified for several accuracy and latency features according to given processing procedures and ancillary input data
- Quality Control product: necessary to assess the quality of SAR imagery generated by standard- and non-standard processors. The Quality Control (QC) function is able to elaborate products by its own, in order to visualize them and to perform temporal evolution analysis and

 	COSMO-SkyMed Mission and Products Description	Doc. N° : ASI-CSM-PMG-NT-001 Date : 31 May 2016 Rev. : Issue 2 Pag. : 39 of 151
PROGRAMMA COSMO-SkyMed		

cross correlation studies. Furthermore, the QC function takes into account the ancillary data, for example the COSMO Orbital Product for the orbital residual trend analysis, and exploits support data (GCP/GRP, DEM, etc) coming from external sources (entities).



 	COSMO-SkyMed Mission and Products Description	Doc. N°. : ASI-CSM-PMG-NT-001 Date : 31 May 2016 Rev. : Issue 2 Pag. : 40 of 151
PROGRAMMA COSMO-SkyMed		

6 Standard Products Format Description

The data packaging organization adopted as distribution format for the civilian standard products is HDF5. The support format detailed below will be used to store image layers and the relevant ancillary information, forming the output product to be distributed to the final user.

6.1 Format Overview

The HDF5 (Hierarchical Data Format) format and software, was developed and supported by NCSA

 	COSMO-SkyMed Mission and Products Description	Doc. N°. : ASI-CSM-PMG-NT-001 Date : 31 May 2016 Rev. : Issue 2 Pag. : 41 of 151
PROGRAMMA COSMO-SkyMed		

- A group header, which contains a group name and a list of group attributes.
- A group symbol table, which is a list of the HDF5 objects that belong to the group.

Working with groups and group members is similar in many ways to working with directories and files in UNIX. As with UNIX directories and files, objects in an HDF5 file are often described by giving their full (or absolute) path names.

/ signifies the root group.

/foo signifies a member of the root group called foo.

/foo/zoo signifies a member of the group foo, which in turn is a member of the root group.

6.1.2 Datasets

A dataset is a multidimensional array of data elements, together with supporting metadata.

A dataset is stored in a file in two parts

- A header
- A data array

Dataset header

The header contains information that is needed to interpret the array portion of the dataset, as well as metadata (or pointers to metadata) that describes or annotates the dataset. Header information includes the name of the object, its dimensionality, its number-type, information about how the data itself is stored on disk, and other information used by the library to speed up access to the dataset or maintain the file's integrity.

There are four essential classes of information in any header:

- Name
- Datatype
- Dataspace
- Storage layout

Name

A dataset name is a sequence of alphanumeric ASCII characters.

Datatype

HDF5 allows one to define many different kinds of datatypes. There are two categories of datatypes:

- atomic datatypes (which differentiates in system-specific, NATIVE or named)
- compound datatypes (which can only be named).



Atomic datatypes are those that are not decomposed at the datatype interface level, such as integers and floats.

NATIVE datatypes are system-specific instances of atomic datatypes.

Compound datatypes are made up of atomic datatypes.

Named datatypes are either atomic or compound datatypes that have been specifically designated to be shared across datasets.

Atomic datatypes include integers and floating-point numbers. Each atomic type belongs to a particular class and has several properties: size, order, precision, and offset. In this introduction, we consider only a few of these properties. Atomic classes include integer, float, date and time, string, bit field, and

 	COSMO-SkyMed Mission and Products Description	Doc. N° : ASI-CSM-PMG-NT-001 Date : 31 May 2016 Rev. : Issue 2 Pag. : 42 of 151
PROGRAMMA COSMO-SkyMed		

opaque. (Note: Only integer, float and string classes are available in the current implementation.) Properties of integer types include size, order (endian-ness), and signed-ness (signed/unsigned). Properties of float types include the size and location of the exponent and mantissa, and the location of the sign bit.

The datatypes that are supported in the current implementation are:

- Integer datatypes: 8-bit, 16-bit, 32-bit, and 64-bit integers in both little and big-endian format.
- Floating-point numbers: IEEE 32-bit and 64-bit floating-point numbers in both little and big-endian format
- References
- Strings
- NATIVE datatypes. Although it is possible to describe nearly any kind of atomic data type, most applications will use predefined datatypes that are supported by their compiler. In HDF5 these are called native datatypes. NATIVE datatypes are C-like datatypes that are generally supported by the hardware of the machine on which the library was compiled. In order to be portable, applications should almost always use the NATIVE designation to describe data values in memory.

The NATIVE architecture has base names that do not follow the same rules as the others. Instead, native type names are similar to the C type names. A compound datatype is one in which a collection of simple datatypes are represented as a single unit, similar to a struct in C. The parts of a compound datatype are called members. The members of a compound datatype may be of any datatype, including another compound datatype. It is possible to read members from a compound type without reading the whole type. Named datatypes. Normally each dataset has its own datatype, but sometimes we may want to share a datatype among several datasets. This can be done using a named datatype. A named data type is stored in the file independently of any dataset, and referenced by all datasets that have that datatype. Named datatypes may have an associated attributes list. See Datatypes in the HDF User's Guide for further information.

Dataspace



A dataset dataspace describes the dimensionality of the dataset. The dimensions of a dataset can be fixed (unchanging), or they may be unlimited, which means that they are extendible (i.e. they can grow larger). Properties of a dataspace consist of the rank (number of dimensions) of the data array, the actual sizes of the dimensions of the array, and the maximum sizes of the dimensions of the array. For a fixed-dimension dataset, the actual size is the same as the maximum size of a dimension. A dataspace can also describe portions of a dataset, making it possible to do partial I/O operations on selections.

Given an n-dimensional dataset, there are currently four ways to do partial selection:

- Select a logically contiguous n-dimensional hyperslab.
- Select a non-contiguous hyperslab consisting of elements or blocks of elements (hyperslabs) that are equally spaced.
- Select a union of hyperslabs.
- Select a list of independent points.

Since I/O operations have two end-points, the raw data transfer functions require two dataspace arguments: one describes the application memory dataspace or subset thereof, and the other describes the file dataspace or subset thereof.

Storage layout

 	COSMO-SkyMed Mission and Products Description	Doc. N°. : ASI-CSM-PMG-NT-001 Date : 31 May 2016 Rev. : Issue 2 Pag. : 43 of 151
PROGRAMMA COSMO-SkyMed		

The HDF5 format makes it possible to store data in a variety of ways. The default storage layout format is contiguous, meaning that data is stored in the same linear way that it is organized in memory. Two other storage layout formats are currently defined for HDF5: compact, and chunked. In the future, other storage layouts may be added. Compact storage is used when the amount of data is small and can be stored directly in the object header. Chunked storage involves dividing the dataset into equal-sized "chunks" that are stored separately. Chunking has three important benefits. It makes it possible to achieve good performance when accessing subsets of the datasets, even when the subset to be chosen is orthogonal to the normal storage order of the dataset. It makes it possible to compress large datasets and still achieve good performance when accessing subsets of the dataset. It makes it possible efficiently to extend the dimensions of a dataset in any direction.

6.1.3 HDF5 Attributes

Attributes are small named datasets that can be attached to one of the following structures:

- primary datasets
- groups
- named datatypes

Attributes can be used to describe the nature and/or the intended usage of a dataset or group. An attribute has two parts:

- name
- value

The value part contains one or more data entries of the same data type. When accessing attributes, they can be identified by name or by an index value. The use of an index value makes it possible to iterate through all of the attributes associated with a given object.

6.2 Products Organization

Specific data organization will be detailed to meet the storage needs of data acquired with all the instrument modes allowed by the COSMO-SkyMed constellation.



6.2.1 Naming Convention

The following naming convention will be used for the identification of the COSMO-SkyMed SAR Standard Products files and the most of the Higher Level Products files. Differences in the convention used for some Higher-Level product is detailed into the specific subsection

CSKS<i>_<YYY_Z>_<MM>_<SS>_<PP>_<s><0>_<D><G>_<YYYYMMDDhhmmss>_<YYYYMMDDhhmmss>.h5



The semantic of the variable sub-strings is reported in the following table:

Sub-string code	Meaning	Allowed values
<i>	Identifier of the satellite within the SAR constellation that acquired the scene	1 2 3 4
<YYY_Z>	Product Type	Standard Products: RAW_B SCS_B SCS_U DGM_B GEC_B GTC_B

 	COSMO-SkyMed Mission and Products Description	Doc. N°. : ASI-CSM-PMG-NT-001 Date : 31 May 2016 Rev. : Issue 2 Pag. : 44 of 151
PROGRAMMA COSMO-SkyMed		

<MM>	Instrument Mode used during the acquisition	HI (Himage) PP (PingPong) WR (WideRegion) HR (HugeRegion) S2 (Spotlight 2)
<SS>	Identifier of the swath (or subswath combination in the case of ScanSAR mode) used for the data acquisition	[0A-0B-01-...-24] for Himage Mode [0A-0B-01-...-23] for PingPong Mode [00-...-07] for WideRegion Mode [00-...-05] for HugeRegion Mode [0A-...-0D-01-...-33] for Enhanced Spotlight Mode
<PP>	Polarizations used during the acquisition	HH = Horizontal Tx/Horizontal Rx for Himage, ScanSAR and Spotlight modes VV = Vertical Tx/ Vertical Rx for Himage, ScanSAR and Spotlight modes HV = Horizontal Tx/ Vertical Rx for Himage, ScanSAR VH = Vertical Tx/ Horizontal Rx for Himage, ScanSAR CO = Co-polar acquisition (HH/VV) for PingPong mode CH = Cross polar acquisition (HH/HV) with Horizontal Tx polarization for PingPong mode CV = Cross polar acquisition (VV/VH) with Vertical Tx polarization for PingPong mode
<s>	Identifier of the Look Side	L = LEFT R = RIGHT
<o>	Identifier of the Orbit Direction	A = Ascending D = Descending
<D>	Delivery Mode	F = Fast Delivery mode S = Standard Delivery mode
<G>	State of the Selective Availability during the acquisition, affecting Orbital Data derived by GPS Instrument	N = ON F = OFF
<YYYYMMDDhhmmss>	Sensing Start Time rounded to the closest integer second	YYYY = year MM = month DD = day of the month hh = hour mm = minute ss = second
<YYYYMMDDhhmmss>	Sensing Stop Time rounded to the closest integer second	As for sensing start time

Table 15 – File naming convention

 	COSMO-SkyMed Mission and Products Description	Doc. N°. : ASI-CSM-PMG-NT-001 Date : 31 May 2016 Rev. : Issue 2 Pag. : 45 of 151
PROGRAMMA COSMO-SkyMed		

6.2.2 Hierarchies organization

The HDF5 allows the hierarchical organization of the information to be stored. In order to standardize the data organization and the access to the image layers stored by the HDF5 support format, each level of the HDF5 hierarchy has been univocally assigned to the storage of a specific level of information of the SAR products according to the scheme described below.

/ - Root group for Instrument Modes (Processing Level): All (0/1A/1B/1C/1D)

For each Instrument Mode and processing level it includes:

- the attributes to be considered applicable to the whole acquisition/product, hence that are subswaths-independent
- one or more group named S<mm> detailed below
- zero or one dataset named MBI (Multi Beam Image) detailed below
- zero or one dataset named QLK (Quick Look) detailed below
- zero or one dataset named GIM (Geocoded Incidence Mask) detailed below

S<mm> groups for Instrument Modes (Processing Level): All (0/1A/1B/1C/1D)

It includes:

- the attributes dependent on the specific subswath used within the full multi-beam swath in the case of ScanSAR mode and within the access area otherwise (for example the PRF)
- one or more dataset named B<nnn> detailed below
- zero or one dataset named SBI (Single Beam Image), in the case of ScanSAR modes, detailed below
- zero or one dataset named QLK (Quick Look) detailed below
- zero or one dataset CAL including all the ShortCal pulses acquired during the acquisition's sequence of the scene echoes.
- zero or one dataset REPLICA including all the reconstructed replica chirp.
- zero or one dataset NOISE including all the Noise measures performed during the acquisition's sequence of the scene echoes.

In the case of Himage and Spotlight products <mm> = 01

In the case of ScanSAR products <mm> \in {01, 02, 03, 04, 05, 06} used in increasing order from the nearest subswath to the farthest one. Moreover, S01 group will always include the earliest acquired burst.

B<nnn> dataset for Instrument Modes (Processing Level): All (0)

It includes:

- the attributes dependent on the time sequential data block (the burst) to be considered applicable for the acquired raw data (for example the Sensing Start Time)
- the data array with the raster layer.

In the case of Himage and Spotlight products <nnn> = 001

In the case of ScanSAR products <nnn> \in [001, 999] used in increasing order from the earliest acquired burst to the latest one. The same number of bursts will be always included in each S<mm> group of the distributed product.



B<nnn> group for Instrument Modes (Processing Level): All (1A/1B/1C/1D)

It includes the attributes dependent on the time sequential data block (the burst) to be considered applicable for the acquired raw data (for example the Sensing Start Time)

SBI dataset for Instrument Modes (Processing Level): Himage, Spotlight (1A/1B/1C/1D) and ScanSAR (1A)

It includes:

- the attributes dependent on the subswath used within the access area to be considered applicable for the distributed product (for example the Line Time Interval)

 	COSMO-SkyMed Mission and Products Description	Doc. N°. : ASI-CSM-PMG-NT-001 Date : 31 May 2016 Rev. : Issue 2 Pag. : 46 of 151
PROGRAMMA COSMO-SkyMed		

- one raster data array representing the product to be distributed

MBI dataset for Instrument Modes: ScanSAR (1B/1C/1D)

It includes

- the attributes dependent on the mosaicked full scene to be considered applicable for the distributed product (for example the Line Time Interval)
- one raster data array representing the range/azimuth mosaicked product to be distributed

QLK Dataset

It includes the quick look of the distributed product.

See 0 for further details.

GIM Dataset

It includes the raster layer representing the mask (coregistered with the GTC product) of the incidence angles at which each pixel included into the level 1D product had been acquired.

START group for Instrument Modes (Processing Level): All (0)

It includes the dataset of Calibration (CAL) and Noise (NOISE) measurements performed during the acquisition initialization sequence extracted from the downlinked RAW data

STOP group for Instrument Modes (Processing Level): All (0)

It includes the dataset of Calibration (CAL) and Noise (NOISE) measurements performed during the acquisition termination sequence extracted from the downlinked RAW data

NOISE dataset for Instrument Modes (Processing Level): All (0)

It includes the Noise data from the downlinked RAW data.

- The dataset START/NOISE (respectively STOP/NOISE), includes the Noise measurements performed during the acquisition Initialization (respectively Termination) sequence;
- The dataset /S<nn>/NOISE, includes all the Noise measures performed during the acquisition's sequence of the scene echoes

CAL dataset for Instrument Modes (Processing Level): All (0)

It includes the Calibration data from the downlinked RAW data. Three cases can be identified:

- the dataset /START/CAL, includes all the Calibration measurements (Tx1a, Tx1b and Rx performed on each row of the antenna plus an additional ShortCal pulse) performed during the acquisition's Initialization sequence;
- the dataset /STOP/CAL, includes all the Calibration measurements (Tx1a, Tx1b and Rx performed on each row of the antenna plus an additional ShortCal pulse) performed during the acquisition's Termination sequence;
- the dataset /S<nn>/CAL, includes all the ShortCal pulses acquired during the acquisition's sequence of the scene echoes.



REPLICA dataset for Instrument Modes (Processing Level): All (0)

It includes the replica chirp reconstructed from the calibration data included into the downlinked RAW data. It includes a number of lines equal to the number of measured ShortCal pulses

6.2.3 Graphical representation of the hierarchical organization for each Instrument Mode and Processing Level

The hierarchical organization for each Instrument Mode and Processing Level is graphically represented in the following diagrams.

A not colour filled structure

 	COSMO-SkyMed Mission and Products Description	Doc. N°. : ASI-CSM-PMG-NT-001 Date : 31 May 2016 Rev. : Issue 2 Pag. : 47 of 151
PROGRAMMA COSMO-SkyMed		

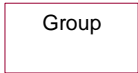

represents a HDF5 structure group.

A colour filled structure

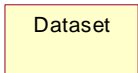

represents a generic HDF5 dataset including data array and the relevant attributes.

Suffixes <mm>/<nnn> between angular brackets indicates that the cardinality of the group/dataset is greater than one.

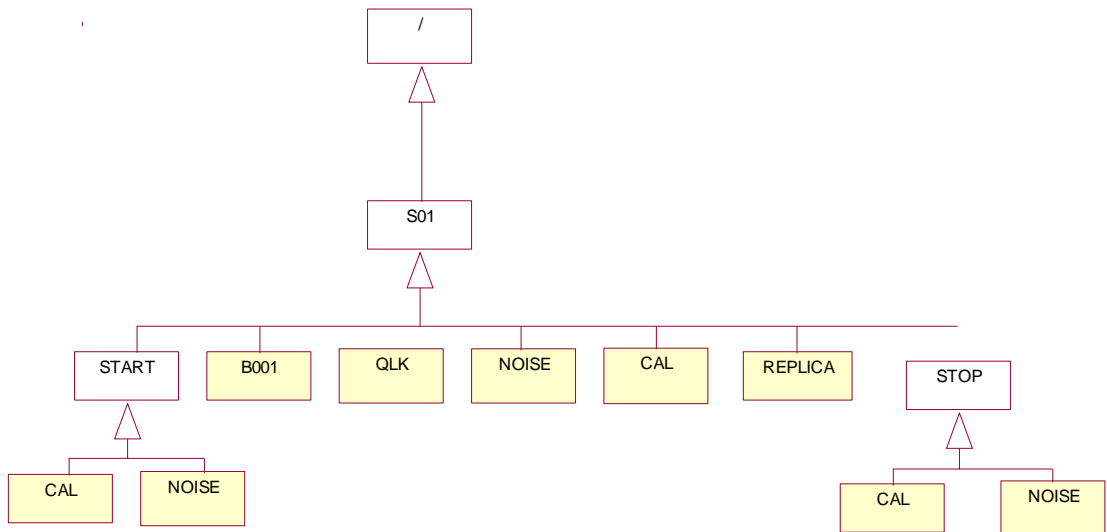

Figure 17 – Himage/Spotlight Mode – Level 0

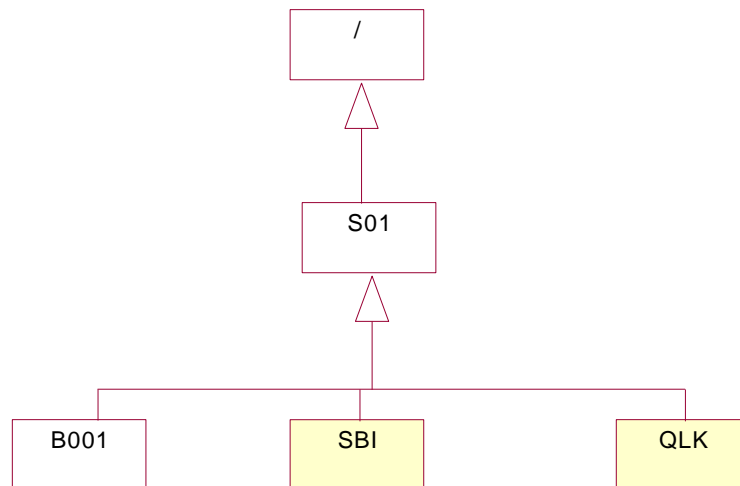

Figure 18 – Himage/Spotlight Mode – Level 1A/1B/1C

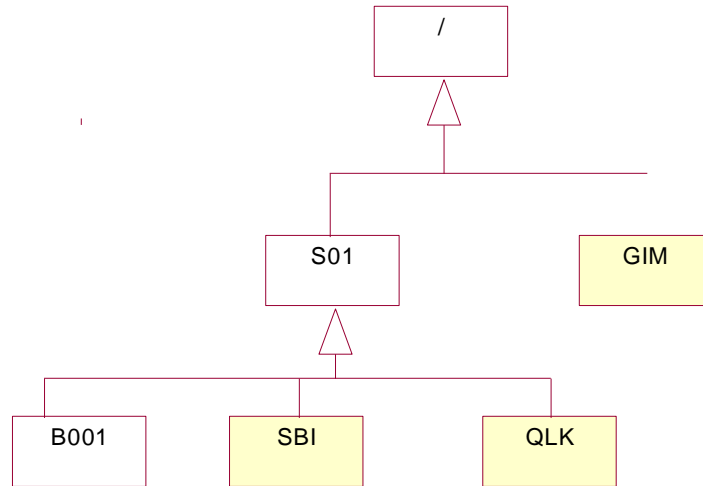

Figure 19 – Himage/Spotlight Mode – Level 1D

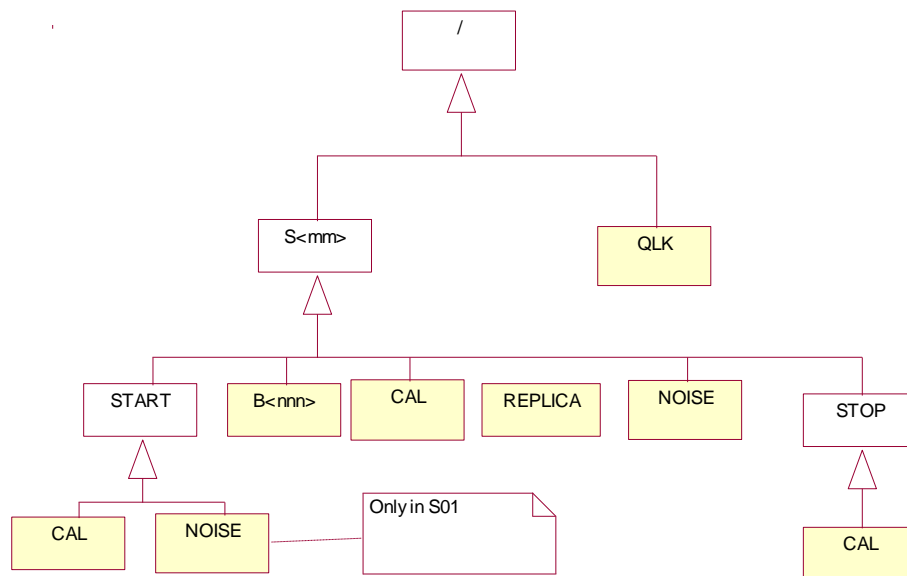



Figure 20 – ScanSAR Mode – Level 0

 	COSMO-SkyMed Mission and Products Description	Doc. N°. : ASI-CSM-PMG-NT-001 Date : 31 May 2016 Rev. : Issue 2 Pag. : 49 of 151
PROGRAMMA COSMO-SkyMed		

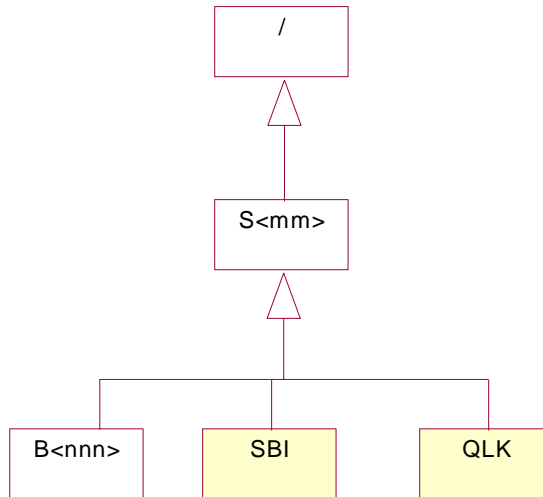

Figure 21 – ScanSAR Mode – Level 1A

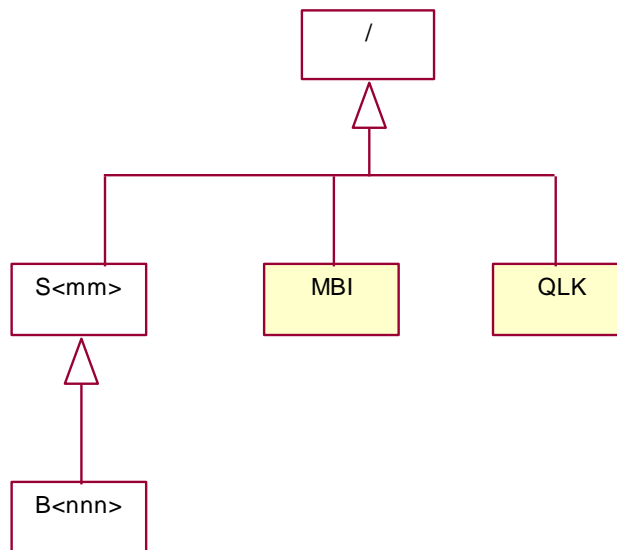

Figure 22 – ScanSAR Mode – Level 1B-1C

PROGRAMMA COSMO-SkyMed

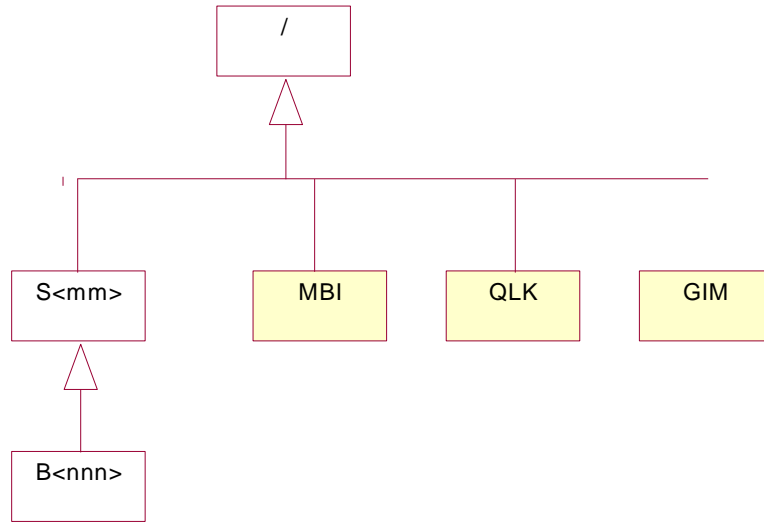

Figure 23 – ScanSAR Mode – Level 1D

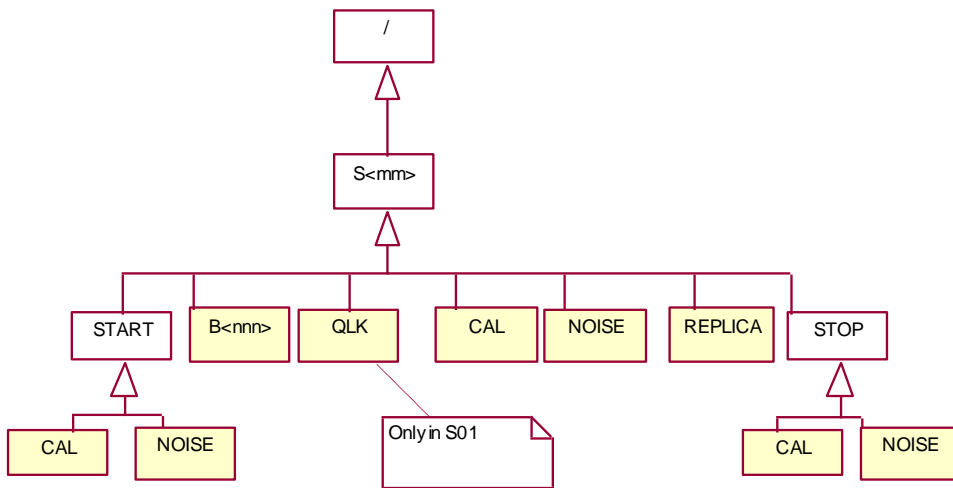

Figure 24 – PingPong Mode – Level 0

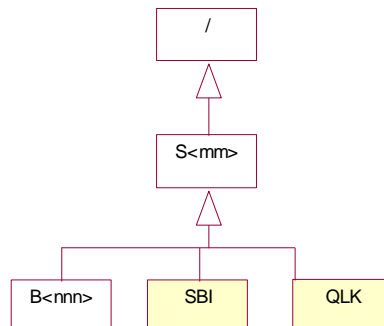



Figure 25 – PingPong Mode – Level 1A/1B/1C

 	COSMO-SkyMed Mission and Products Description	Doc. N°. : ASI-CSM-PMG-NT-001 Date : 31 May 2016 Rev. : Issue 2 Pag. : 51 of 151
PROGRAMMA COSMO-SkyMed		

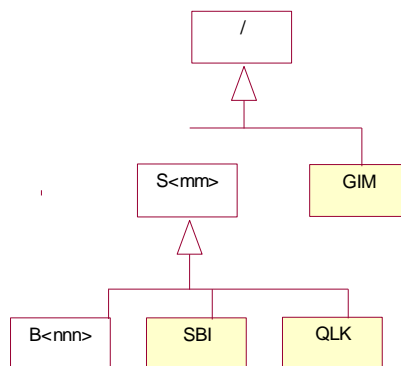



Figure 26 – PingPong Mode – Level 1D

6.2.4 Quick Look layer

A synoptic of the entire datum allowing having a look to the image content is annexed to all SAR standard and higher-level product. For product at processing level 1, the quick look is originated by undersampling of the full resolution raster layer, obtained by a filter (realized by a kernel of configurable size) moving in the raw and columns directions at steps derived by the ratios of the output and input spacing. Following tables details features of the quick look layer.

Products	Sample Information	Projection
Lev. 0	Focused image, detected, extracted from the Quick Look generated at the ISF screening time. In the case of PingPong product, the Quick Look layer is annexed only to data included into S01 group.	Ground Range/Azimuth
Lev. 1A	The same sample information of the distributed product the quick look is annexed to, detected, undersampled both in range and azimuth direction with the following factors depending on the sensor mode: SMART: 25 Enh. Spotlight: 25 Himage: 30 PingPong: 25 WideRegion: 15 HugeRegion: 15 One image per subswath (resp. polarization) in ScanSAR (resp. PingPong) Mode	Slant Range/Azimuth
Lev. 1B	The same sample information of the distributed product the quick look is annexed to, undersampled both in range and azimuth direction to the pixel/line spacings depending on the sensor mode	Ground Range/Azimuth

 	COSMO-SkyMed Mission and Products Description	Doc. N°. : ASI-CSM-PMG-NT-001 Date : 31 May 2016 Rev. : Issue 2 Pag. : 52 of 151
PROGRAMMA COSMO-SkyMed		

Products	Sample Information	Projection
Lev. 1C/1D	As for level 1B	UTM (-80 ≤ center latitude ≤ 84°) UPS (otherwise)

Table 16 – Features of the Quick Look layers

Dataset	Sample Format	Bits per Sample	Samples per Pixel	Type Represent.	Invalid Value
Quick Look annexed to the Full resolution product	Unsigned Integer	8	1	Little Endian	0

Table 17 – Data type for Quick look layer

6.2.5 Ancillary information organization

The attributes to be appended (in terms of HDF5 Attributes) to the COSMO-SkyMed SAR standard products, depending on the processing Level (from Level 0 up to Level 1D) are listed in the Appendix section, at the end of this document. For each attribute the corresponding HDF5 storage structure is reported.

6.2.6 Data storage policy

The arrangement used for storage of raster data layers of the SAR Standard Products into HDF5 datasets is listed in the following table:

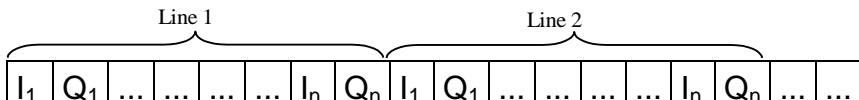
Samples per pixel	HDF5 data type
Two (Complex data)	<p>Tri-dimensional array having:</p> <ul style="list-style-type: none"> the first dimension (the slowest varying) corresponding to the number of lines of the data array the second dimension corresponding to the number of columns of the data array the third dimension (the most fast varying) corresponding to the pixel depth, hence used for representation of Real and Imaginary part of each pixel Such representation, will be used for complex types independently on the sample format (byte, short, integer, long, long long, float, double) and sign (signed, unsigned). <p>Data organization in file is shown in the following schema</p> <div style="text-align: center;">  </div>

 	COSMO-SkyMed Mission and Products Description	Doc. N°. : ASI-CSM-PMG-NT-001 Date : 31 May 2016 Rev. : Issue 2 Pag. : 53 of 151
PROGRAMMA COSMO-SkyMed		



Samples per pixel	HDF5 data type
One (Real data)	Bi-dimensional array having: <ul style="list-style-type: none"> the first dimension (the slowest varying) corresponding to the number of lines of the data array the second dimension corresponding to the number of columns of the data array Such representation will be used for images on single-sample pixel, independently on the sample format (byte, short, integer, long, long long, float, double) and sign (signed, unsigned) <div style="text-align: center; margin-top: 10px;">  </div>

Table 18

The following chunking policy for data storage is recommended.

Dimension	Chunk Size
Image Length (Lines)	128
Image Width (Columns)	128
Image Depth (Samples)	2

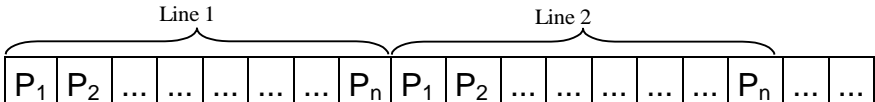
Table 19

 	COSMO-SkyMed Mission and Products Description	Doc. N°. : ASI-CSM-PMG-NT-001 Date : 31 May 2016 Rev. : Issue 2 Pag. : 54 of 151
PROGRAMMA COSMO-SkyMed		

7 Higher Level Products Format Description

7.1 Quick-Look Product

The Quick Look Product will be a synoptic of the entire datum allowing having a look to the image content in a faster way than by processing the image according to the standard algorithms. The Quick Look product (in the following referred as QLF) is originated from the Level 0 file in the archiving format used at UGS; it is originated on the entire Image Segment File at the screening time, and it is mainly used for cataloguing purposes.

The Quick Look File consists of the following datasets:

- ACQMetadata Dataset: This dataset contains the XML file relating to the metadata used by ACQ to internally catalogue a new L0F.
- QLF Dataset: It is composed by binary records containing the image data. See Table 4 3 “Data type for Quick look layer” for details.
- RawKey Dataset: This dataset contains the RawKey.xml file formatted 8-bit signed char. The organization of this file is shown below.

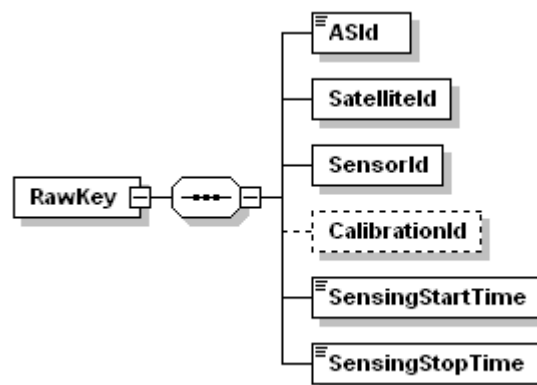



Figure 27

Parameter	Description
ASId	Acquisition Station Identifiers
Satelliteld	Satellite Identifier
SensorId	Value = SAR
CalibrationID	CAL_EXT (in case of EXTCAL mode) CAL_IFCAL (in case of IFCAL mode) CAL_TR (in case of TRCAL mode) CAL_BITE (in case of BITE mode)
SensingStartTime	The first time annotated into the raw data Time stamp just in case of IFCAL, TRCAL and BITE mode.
SensingStopTime	The last time annotated into the raw data Time stamp just in case of IFCAL, TRCAL and BITE mode.

Table 20

 	COSMO-SkyMed Mission and Products Description	Doc. N°. : ASI-CSM-PMG-NT-001 Date : 31 May 2016 Rev. : Issue 2 Pag. : 55 of 151
PROGRAMMA COSMO-SkyMed		

```

<!--=====-->
<!-- External DTD Reference -->
<!--=====-->
<!-- Data format include -->
<!ENTITY % DataFormat.dtd SYSTEM "DataFormat.dtd">
%DataFormat.dtd;
<!ENTITY % ASId.dtd SYSTEM "ASId.dtd">
%ASId.dtd;
<!ENTITY % Satelliteld.dtd SYSTEM "Satelliteld.dtd">
%Satelliteld.dtd;
<!-- -->
<!--=====-->
<!-- Root -->
<!--=====-->
<!ELEMENT RawKey (ASId, Satelliteld, SensorId, CalibrationId?, SensingStartTime, SensingStopTime)>
<!--=====-->
<!-- List of elements -->
<!--=====-->
<!ELEMENT SensorId EMPTY>
<!ATTLIST SensorId
    Value (SAR) #REQUIRED
    %StringFormat;
>
<!ELEMENT CalibrationId EMPTY>
<!ATTLIST CalibrationId
    Value (CAL_EXT | CAL_TR | CAL_IF | BITE) #REQUIRED
    %StringFormat;
>
<!ELEMENT SensingStartTime (#PCDATA)>
<!ATTLIST SensingStartTime
    %DateFormat;
    Format CDATA #FIXED "YYYY-MM-DD hh:mm:ss.nnnnnn"
>
<!ELEMENT SensingStopTime (#PCDATA)>
<!ATTLIST SensingStopTime
    %DateFormat;
    Format CDATA #FIXED "YYYY-MM-DD hh:mm:ss.nnnnnn"
>
<!-- end RawKey.dtd -->
~
~

```



Image specification of the QLF product, are listed in section #0.

7.2 Speckle Filtered Products

The COSMO-SkyMed processor generating “Higher Level Speckle Filtered Product” deals with the improvement of the radiometric resolution of the SAR images by means of the reduction of the intrinsic multiplicative-like speckle noise.

7.2.1 Output Format

The basic CSK SAR output format is based on the Hierarchical Data Format version 5 developed by NCSA at the University of Illinois, fully detailed in NCSA, “HDF5 Document Set”, release 1.4.1 April 2001, web site: <http://hdf.ncsa.uiuc.edu/HDF5/doc/>.

 	COSMO-SkyMed Mission and Products Description	Doc. N°. : ASI-CSM-PMG-NT-001 Date : 31 May 2016 Rev. : Issue 2 Pag. : 56 of 151
PROGRAMMA COSMO-SkyMed		

Data Type

The following table summarizes the data types to be used for storage of the Speckle filtered data arrays, independently on the SAR operation mode.

Product	Dataset	Sample Format	Bits per Sample	Samples per Pixel	Type Represent.	Invalid Value
SPF_B	Speckle Filtered signal amplitude	Unsigned Integer	16	1	Little Endian	0

Table 21 - Data types for Speckle Filtered products

HDF5 Organization

The Speckle Filtered Product strictly follows the SAR Level 1B format organization

7.3 Co-registered Product

Two different images covering the same area can be made superposable by means of the co-registration which is the process of lining up two images, a so-called master image and a slave image, in a way that they fit exactly on top of each other without adding artifacts in the image intensity and phase components.

7.3.1 Output Format



The basic CSK SAR output format is based on the Hierarchical Data Format version 5 developed by NCSA at the University of Illinois, fully detailed in NCSA, "HDF5 Document Set", release 1.4.1 April 2001, web site: <http://hdf.ncsa.uiuc.edu/HDF5/doc/>.

Data Type

The following table summarizes the data types to be used for storage of the co-registered data arrays, depending on the processing Level (Level 1A or Level 1B) of the input data to the coregistration processor, independently on the SAR operation mode.

Product	Dataset	Sample Format	Bits per Sample	Samples per Pixel	Type Represent.	Invalid Value
CRG_A	Coregistered SAR Data	Signed Integer	16	2	Little Endian	[0, 0]
CRG_B	Coregistered SAR Data	Unsigned Integer	16	1	Little Endian	0

Table 22 - Data types for Co-registered products

 	COSMO-SkyMed Mission and Products Description	Doc. N°. : ASI-CSM-PMG-NT-001 Date : 31 May 2016 Rev. : Issue 2 Pag. : 57 of 151
PROGRAMMA COSMO-SkyMed		

HDF5 Organization

The Co-registered Product strictly follows the SAR Level 1A and 1B format organization, depending on the processing level of the input images.

7.4 Interferometric Products

Synthetic aperture radar interferometry is an imaging technique for measuring the topography of the surface and its changes over time. The Interferometric products are derived, by post-processing of the SAR Level 1A coregistered products, in any acquisition mode except PingPong. Interferometric products includes the following products' class:

- the interferometric phase (interferogram)
- the coherence map.

7.4.1 Output Format



The basic CSK SAR output format is based on the Hierarchical Data Format version 5 developed by NCSA at the University of Illinois, fully detailed in NCSA, "HDF5 Document Set", release 1.4.1 April 2001, web site: <http://hdf.ncsa.uiuc.edu/HDF5/doc/>.

Data Type

The following table summarizes the data types to be used for storage of the Interferometric data arrays, independently on the SAR operation mode.

Product	Dataset	Sample Format	Bits per Sample	Samples per Pixel	Type Represent.	Invalid Value
IPH_B	Interferogram	Floating Point	32	1	Little Endian	QNaN
	Demodulation Phase	Floating Point	32	1	Little Endian	QNaN
COH_B	Coherence	Floating Point	32	1	Little Endian	QNaN

Table 23 - Data types for Interferometric products

 	COSMO-SkyMed Mission and Products Description	Doc. N°. : ASI-CSM-PMG-NT-001 Date : 31 May 2016 Rev. : Issue 2 Pag. : 58 of 151
PROGRAMMA COSMO-SkyMed		

HDF5 Organization

The hierarchical organization of the IPH_B product for each Instrument Mode is graphically represented in the following diagrams.

A not color filled structure

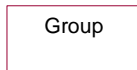

represents a HDF5 structure group.

A color filled structure

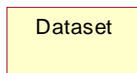

represents a generic HDF5 dataset including data array and the relevant attributes.

Suffixes <mm>/<nnn> between angular brackets indicates that the cardinality of the group/dataset is greater than one.

In the following figures:

- SBI dataset includes the interferometric phase layer
- DPH dataset includes the demodulation phase layer

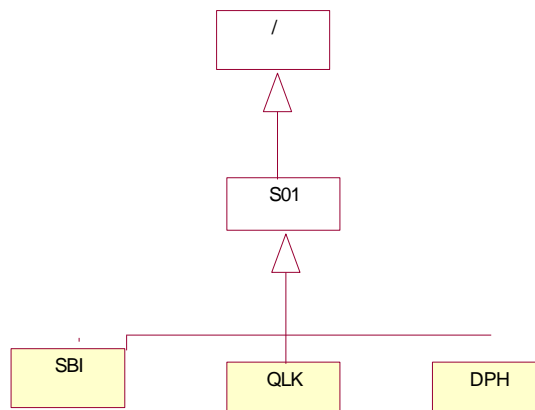



Figure 28 – Himage/Spotlight Mode – IPH_B Product

 	COSMO-SkyMed Mission and Products Description	Doc. N°. : ASI-CSM-PMG-NT-001 Date : 31 May 2016 Rev. : Issue 2 Pag. : 59 of 151
PROGRAMMA COSMO-SkyMed		

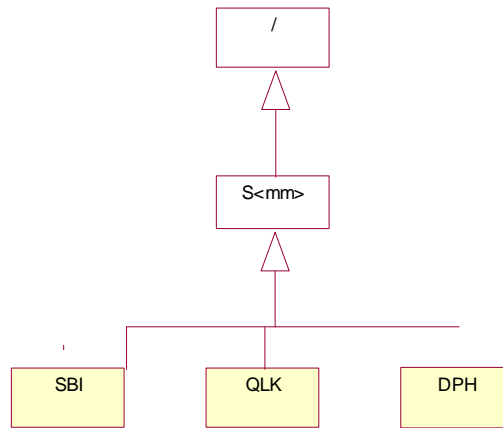

Figure 29 – ScanSAR Mode – IPH_B Product

In the following figures SBI dataset includes the coherence layer

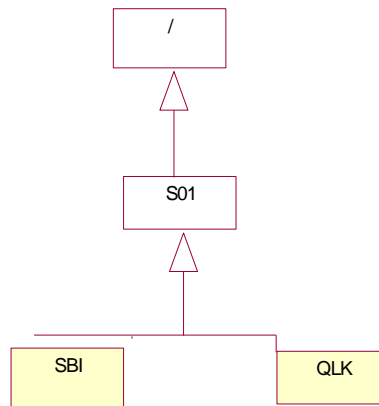

Figure 30 – Himage/Spotlight Mode – COH_B Product

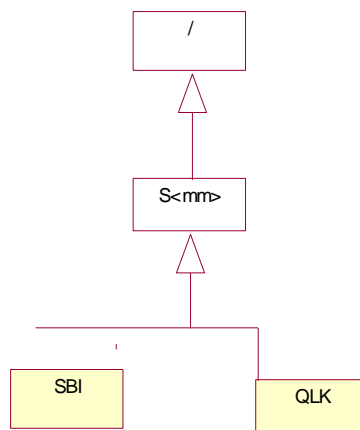



Figure 31 – ScanSAR Mode – COH_B Product



 	COSMO-SkyMed Mission and Products Description	Doc. N°. : ASI-CSM-PMG-NT-001 Date : 31 May 2016 Rev. : Issue 2 Pag. : 60 of 151
PROGRAMMA COSMO-SkyMed		

7.5 DEM product

The interferometric DEM products are derived, by post-processing of the SAR interferometric products. DEM products consist of the ellipsoidal height map and the associated height error map. The attributes defining the DEM products are derived from the SAR image couple, with some substantial changes (e.g. due to the change of the image projection). The DEM product is presented in UTM/UPS cartographic coordinate system respect to WGS84 ellipsoid, different from the input geometry (slant-range). In the case of DEM product originated from ScanSAR interferometric couple, output is presented in a single layer having elementary beams mosaicked in the range direction.

7.5.1 Output Format

The basic CSK SAR output format is based on the Hierarchical Data Format version 5 developed by NCSA at the University of Illinois, fully detailed in NCSA, "HDF5 Document Set", release 1.4.1 April 2001, web site: <http://hdf.ncsa.uiuc.edu/HDF5/doc/>.

 	COSMO-SkyMed Mission and Products Description	Doc. N°. : ASI-CSM-PMG-NT-001 Date : 31 May 2016 Rev. : Issue 2 Pag. : 61 of 151
PROGRAMMA COSMO-SkyMed		

Data Type

The following table summarizes the data types to be used for storage of the DEM product data layers, independently on the SAR operation mode.

Product	Dataset	Sample Format	Bits per Sample	Samples per Pixel	Type Represent.	Invalid Value
DTM_H	Height Model	Floating Point	32	1	Little Endian	QNaN
	Height Error Map	Floating Point	32	1	Little Endian	QNaN

Table 24 - Data types for DEM product

HDF5 Organization

The hierarchical organization of the DEM product for each Instrument Mode is graphically represented in the following diagrams.

A not color filled structure

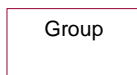

represents a HDF5 structure group.

A color filled structure

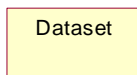

represents a generic HDF5 dataset including data array and the relevant attributes.

Suffixes <mm>/<nnn> between angular brackets indicates that the cardinality of the group/dataset is greater than one.

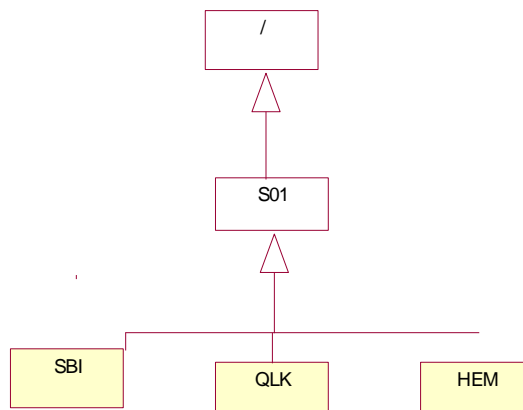



Figure 32 – Himage/Spotlight Mode – DEM Product

 	COSMO-SkyMed Mission and Products Description	Doc. N°. : ASI-CSM-PMG-NT-001 Date : 31 May 2016 Rev. : Issue 2 Pag. : 62 of 151
PROGRAMMA COSMO-SkyMed		

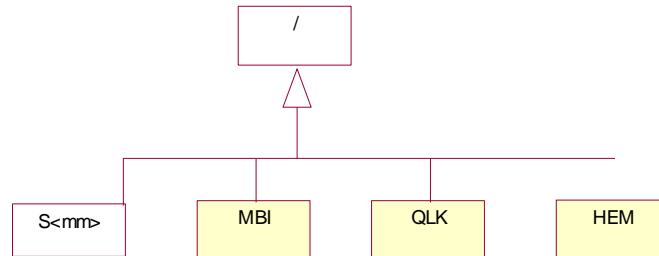

Figure 33 – ScanSAR Mode – DEM Product

7.6 Mosaicked Product

Mosaicking is the capability of assembling Level 1B, geocoded or DEMs images or strips into a common grid, in order to generate a large-scale map.

7.6.1 Output Format

The basic CSK SAR output format is based on the Hierarchical Data Format version 5 developed by NCSA at the University of Illinois, fully detailed in NCSA, “HDF5 Document Set”, release 1.4.1 April 2001, web site: <http://hdf.ncsa.uiuc.edu/HDF5/doc/>.

Data Type

The following table summarizes the data types to be used for storage of the Mosaicked data arrays, independently on the SAR operation mode.

Product	Dataset	Sample Format	Bits per Sample	Samples per Pixel	Type Represent.	Invalid Value
MOS_B	SAR Image	Unsigned Integer	16	1	Little Endian	0
MOS_C	SAR Image	Unsigned Integer	16	1	Little Endian	0
MOS_D	SAR Image	Unsigned Integer	16	1	Little Endian	0
MOS_H	Heght	Float	32	1	Little Endian	QNaN
	Height Error Map	Float	32	1	Little Endian	QNaN

Table 25 - Data types for Mosaicked products

HDF5 Organization

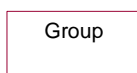

The hierarchical organization of the Mosaicked product for each Instrument Mode is graphically represented in the following diagrams.

A not color filled structure



represents a HDF5 structure group.

A color filled structure

 	COSMO-SkyMed Mission and Products Description	Doc. N°. : ASI-CSM-PMG-NT-001 Date : 31 May 2016 Rev. : Issue 2 Pag. : 63 of 151
PROGRAMMA COSMO-SkyMed		

Dataset

represents a generic HDF5 dataset including data array and the relevant attributes.

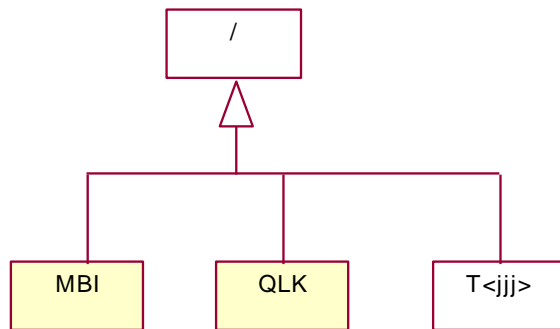

Figure 34 – Himage/Spotlight/ScanSAR Modes – Mosaicked Level 1B/1C/1D Products

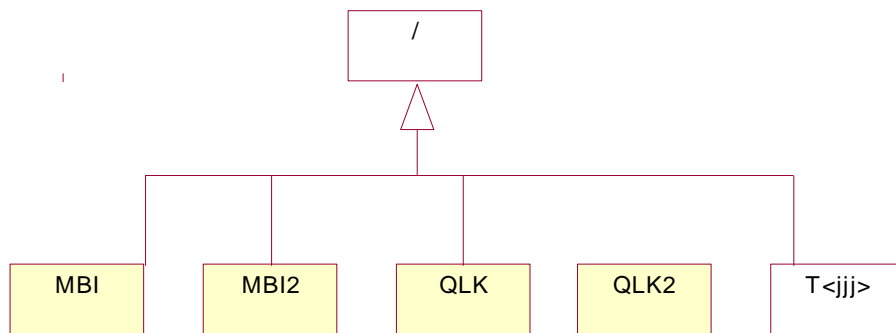

Figure 35 – PingPong Mode – Mosaicked Level 1B/1C/1D Products

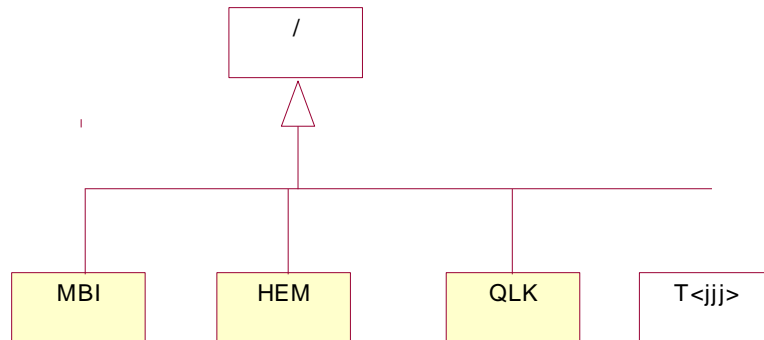



Figure 36 – Mosaicked DEM Product

 	COSMO-SkyMed Mission and Products Description	Doc. N°. : ASI-CSM-PMG-NT-001 Date : 31 May 2016 Rev. : Issue 2 Pag. : 64 of 151
PROGRAMMA COSMO-SkyMed		

8 APPENDIX 1: COSMO-SkyMed Image Calibration

The radiometric calibration of SAR images consists in the evaluation of the radiometric values. These are independent of geometry and radar characteristics and dependent only on the terrain scattering features.

The effects that must be considered are:

- Range spreading loss effect
- Antenna pattern gain compensation
- Incidence angle effect

In the COSMO-SkyMed SCS_B, DGM_B, GEC_B and GTC_B images, all factors different pixel by pixel have been already corrected. So the square of the Digital Numbers (DN) of the images are related to the terrain backscattering coefficients σ^0 through a constant number.

Note: all the data considered above use the WGS84 ellipsoid for the terrain correction, a part from GTC_B. The “terrain corrected” products (GTC_B) are processed using a Digital Elevation Model (DEM) which is used to evaluate the geometric calibration factors too.

SIGMA NAUGHT (σ^0) EVALUATION

In the following, the steps that must be carried out to obtain backscattering coefficient image starting from DN are described.

The necessary parameters involved in the backscattering image generation are listed in a subsequent table. They could be extracted from metadata.

Note: the σ^0 coefficients are defined in ground. So, extraction of σ^0 coefficients from SCS images (level 1A) means to have ground projected values in a slant geometry.

This must be taken into account if the backscattering image would be extracted. The ground projection is the natural projection in which backscattering coefficients are defined, so it's better to use DGM_B images if you need calibrated images values.



For the image levels listed above and for any acquisition mode, the steps to obtain the calibrated values from the DN of image are the following:

Step	Conditions	Description	Formula
1		Evaluate the power image	$P(i,j) = img_{inp(i,j)} ^2$
2	$Rsl_{flag} \neq NONE$	Remove the Reference Slant Range	$Fact = (R_{ref})^{2 \cdot R_{sl}}$
3	$Inc_{flag} \neq NONE$	Remove the Reference Incidence Angle	$Fact' = Fact * \sin \alpha_{ref}$
4		Remove the Rescaling Factor	$Fact'' = Fact' \cdot \frac{1}{F^2}$
5	$K_{flag} = 0$	Apply the Calibration Factor	$F_{Tot} = Fact'' \cdot \frac{1}{K}$
6		Apply the total scaling factor	$\sigma^{0(i,j)} = P(i,j) * F_{Tot}$

Table 26

To get σ^0 in dB:

$$\sigma^{0(i,j)}_{dB} = 10 \log_{10} \sigma^0(i,j)$$

 	COSMO-SkyMed Mission and Products Description	Doc. N°. : ASI-CSM-PMG-NT-001 Date : 31 May 2016 Rev. : Issue 2 Pag. : 65 of 151
PROGRAMMA COSMO-SkyMed		

Note:

When starting from complex products (SCS_B)*, particular attentions must be taken in power calculation in order to avoid artefacts generation. Generally speaking, the power image evaluation must be done considering also an interpolation by two in order to enlarge the image spectral support; then the first step of Tab.1 can be applied.

The σ^0 obtained as described in Tab.1: steps for σ^0 evaluation is the evaluation of the single pixel backscattering coefficient; in order to have a more significant result a running window average has to be done for σ^0 evaluation.

The form of the final backscattering image is obtained with a formula like the following one:



$$\langle \sigma(r, c) \rangle = \sum_{i,j}^{wid_r, wid_c} \sigma^0 + r \cdot wid_r + \frac{wid_r}{2} \cdot j + c \cdot wid_c + \frac{wid_c}{2}$$

or, in logarithmic units

 	COSMO-SkyMed Mission and Products Description	Doc. N°. : ASI-CSM-PMG-NT-001 Date : 31 May 2016 Rev. : Issue 2 Pag. : 66 of 151
PROGRAMMA COSMO-SkyMed		

Flag indicating if the Incidence Angle Compensation has been applied	Incidence Angle Compensation Geometry	<i>Incflag</i>	NA
Flag indicating if the calibration constant has been applied	Calibration Constant Compensation Flag	<i>Kflag</i>	booleam

Table 27 - Parameters used in the radiometric equalization of the COSMO images

 	COSMO-SkyMed Mission and Products Description	Doc. N°. : ASI-CSM-PMG-NT-001 Date : 31 May 2016 Rev. : Issue 2 Pag. : 67 of 151
PROGRAMMA COSMO-SkyMed		

9 Appendix 2: Product Attributes

Next table lists, defines and specifies all attributes included in at least one of the SAR Standard or Higher Level Product. The presence of an attribute in a given product is indicated by the last columns, one for each SAR Product; the following symbols are used depending on the operation to be executed for attribute confirmation:

- “a” is used when it is in complete charge of the processor which generates the product, independently on the presence and correctness of the attribute in the input product (e.g. this is the case of some attributes of the “Formatting” class)
- “m” means the attribute is modified (i.e. it is present in the input product and the input value is used to determinate the output one)
- “x” means the attribute is copied from the input product (i. e. its correctness depends on that one of the input value)

In the symbols usage, the exceptions applicable to some sensor modes or deriving from special algorithmic implementations are not taken into consideration.

As far as the column “HDF5 struct” included into next table, it gives the dataset/group where the attribute is annexed. In the case more than one location is indicated, in most cases only one of them is available into the product (therefore ambiguities are absent); for exceptions, see the description of the attribute. Attributes of the dataset MBI and QLK, are also included in dataset MBI2 and QLK2 of the mosaic ked product.

Concerning with the “Data Type” field the following semantics have to be considered.

Data Type	Number of bits	Sign feature	Type Representation	Default Invalid Value	HDF5 type
UByte	8	Unsigned		0	H5T_STD_U8LE
UShort	16	Unsigned	Little Endian	0	H5T_STD_U16LE



COSMO-SkyMed Mission and Products Description

Doc. N°. : ASI-CSM-PMG-NT-001
 Date : 31 May 2016
 Rev. : Issue 2
 Pag. : 68 of 151

PROGRAMMA COSMO-SkyMed

Area	Attribute name	Description	HDF5 Struc.	Data Type	Unit / ASCII repr.	RAW	SCS	DGM DSM	GEC	GTC	SPF	CRG	IPH COH	DEM	MOS	PBR	RGC	AZP	DOP	QLK	
Acquisition	EndOfCoverage	End Date and Time of the item temporal coverage in the string <u>format</u> : YYYY-MM-DD hh:mm:ss.ddddd	Root	String																	x
Acquisition	Final On Board Time	Value of the on-board time (derived from the on-board counter annotated in the Level 0 data) corresponding to the last line of the Level 0 file used as input. It is not referred to the Reference UTC attribute, but to the last time the on board counter was zeroed.	B<nnn>	Double	s	a	x	x	x	x	x	x				x	x	x			
Acquisition	Frame	WRS Frame Number	Root	UInt 5char																	x
Acquisition	Gain	Gain Value in milli-dB	Root	Int 9digit																	x
Acquisition	Initial On Board Time	Value of the on-board time (derived from the on-board counter annotated in the Level 0 data) corresponding to the first line of the Level 0 file used as input. It is not referred to the Reference UTC attribute, but to the last time the on board counter was zeroed.	B<nnn>	Double	s	a	x	x	x	x	x	x				x	x	x			
Acquisition	Leap Sign	Sign of the occurrence of the leap second (if occurred during the scene acquisition)	Root	Short		a	x	x	x	x	x	x				x	x	x			
Acquisition	Leap UTC	UTC time of the occurrence of the leap second (if occurred during the scene acquisition); equal to "NULL" if no leap second occurred	Root	String	Epoch	a	x	x	x	x	x	x				x	x	x			
Acquisition	MOS Latest Tile UTC	Final acquisition time of latest mosaicked tile	Root	String	Epoch										a						



COSMO-SkyMed Mission and Products Description

Doc. N°. : ASI-CSM-PMG-NT-001
 Date : 31 May 2016
 Rev. : Issue 2
 Pag. : 69 of 151

PROGRAMMA COSMO-SkyMed

Area	Attribute name	Description	HDF5 Struc.	Data Type	Unit / ASCII repr.	RAW	SCS	DGM DSM	GEC	GTC	SPF	CRG	IPH COH	DEM	MOS	PBR	RGC	AZP	DOP	QLK	
Acquisition	MOS Oldest Tile UTC	Initial acquisition time of the oldest mosaicked tile	Root	String	Epoch										a						
Acquisition	Orbit Number	Orbit Number relevant to the Scene Start Time. Set to zero if not available.	Root	UInt		a	x	x	x	x	x	x				x	x	x			
Acquisition	OrbitNumber	Absolute Orbit Number corresponds to ISF start time where the ISF start time is intended the same of the field StartOfCoverage.	Root	UInt 8char																	x
Acquisition	PassEquatorXLongitude	Nadir Equator Crossing Longitude for this Pass Example: 160.98	Root	Double Int digits: 3 decimal s: 2																	x
Acquisition	Polarization	Polarization. Allowed values: VV <i>Vertical Vertical</i> HH <i>Horizontal Horizontal</i> VH <i>Vertical Horizontal</i> HV <i>Horizontal Vertical</i> CO <i>Co-Polar</i> CH <i>Cross-Polar H</i> CV <i>Cross-Polar V</i>	Root	String 2char																	x
Acquisition	Programmed Image ID	Image ID as it was programmed by Ground Segment and downlinked in the packet header	Root	UShort		a	x	x	x	x	x	x				x	x	x			



COSMO-SkyMed Mission and Products Description

Doc. N°. : ASI-CSM-PMG-NT-001
 Date : 31 May 2016
 Rev. : Issue 2
 Pag. : 70 of 151

PROGRAMMA COSMO-SkyMed

Area	Attribute name	Description	HDF5 Struc.	Data Type	Unit / ASCII repr.	RAW	SCS	DGM DSM	GEC	GTC	SPF	CRG	IPH COH	DEM	MOS	PBR	RGC	AZP	DOP	QLK	
Acquisition	QuickLookFirstLineTime	Date and Time at Zero doppler of the first line of the QLF layer in the string format: YYYY-MM-DD hh:mm:ss.dddddd the possible reverse Late/Early is taken into account	Root	String																	x
Acquisition	QuickLookLastLineTime	Date and Time at Zero doppler of the last line of the QLF layer in the string format: YYYY-MM-DD hh:mm:ss.dddddd the possible reverse Late/Early is taken into account	Root	String																	x
Acquisition	Scene Sensing Start UTC	Initial acquisition time of the scene in UTC, derived from the OBT extracted from the downlinked product. Attribute updating is applicable in the case of processing of image portion starting from Level 0 data. For mosaicked products it is annexed only to tiles. Set to invalid value in the case of mosaicked DEM	Root T<jjj>	String	Epoch	a	m	m	x	x	x	x			x	x	m	m			



COSMO-SkyMed Mission and Products Description

Doc. N°. : ASI-CSM-PMG-NT-001
 Date : 31 May 2016
 Rev. : Issue 2
 Pag. : 71 of 151

PROGRAMMA COSMO-SkyMed

Area	Attribute name	Description	HDF5 Struc.	Data Type	Unit / ASCII repr.	RAW	SCS	DGM DSM	GEC	GTC	SPF	CRG	IPH COH	DEM	MOS	PBR	RGC	AZP	DOP	QLK
Acquisition	Scene Sensing Stop UTC	Final acquisition time of the scene in UTC, derived from the OBT extracted from the downlinked product. Attribute updating is applicable in the case of processing of image portion starting from Level 0 data. For mosaicked products it is annexed only to tiles. Set to invalid value in the case of mosaicked DEM	Root T<jjj>	String	Epoch	a	m	m	x	x	x	x			x	x	m	m		
Acquisition	Selective Availability Status	Status of the Selective Availability during the acquisition, affecting Orbital Data derived by GPS Instrument	Root	String		a	x	x	x	x	x	x				x	x	x		



COSMO-SkyMed Mission and Products Description

Doc. N°. : ASI-CSM-PMG-NT-001
 Date : 31 May 2016
 Rev. : Issue 2
 Pag. : 72 of 151

PROGRAMMA COSMO-SkyMed

Area	Attribute name	Description	HDF5 Struc.	Data Type	Unit / ASCII repr.	RAW	SCS	DGM DSM	GEC	GTC	SPF	CRG	IPH COH	DEM	MOS	PBR	RGC	AZP	DOP	QLK		
Acquisition	SensorModeDescription	Descriptive text of specific sensor mode Allowed values: SP_ENHANCED SP_SMART SCN_WIDE SCN_HUGE STR_HIMAGE STR_PINGPONG	Root	String 50char																	x	
Acquisition	SensorModel	Specific sensor mode Allowed values: S2 S1 WR HR HI PP	Root	String 20char																		x
Acquisition	StartOfCoverage	Start Date and Time of the item temporal coverage in the string <u>format</u> : YYYY-MM-DD hh:mm:ss.ddddd	Root	String																		x
Acquisition	Track	WRS Track Number	Root	UInt 5char																		x
Calibration	ADC Characterization	Look Up Table for ADC Characterization; it associates the signal power detected in the 8 bits RAW data to the ideal analog level in dB. For future usage	Root	Double(256, 2)		a	x	x	x	x	x	x				x	x	x				



COSMO-SkyMed Mission and Products Description

Doc. N°. : ASI-CSM-PMG-NT-001
 Date : 31 May 2016
 Rev. : Issue 2
 Pag. : 73 of 151

PROGRAMMA COSMO-SkyMed

Area	Attribute name	Description	HDF5 Struc.	Data Type	Unit / ASCII repr.	RAW	SCS	DGM DSM	GEC	GTC	SPF	CRG	IPH COH	DEM	MOS	PBR	RGC	AZP	DOP	QLK
Calibration	ADC Compensation	Flag showing the application of the ADC compensation. For future usage	Root	UByte			a	x	x	x	x	x				x				
Calibration	Antenna Pattern Compensation Reference Surface	Designator of the surface used for the compensation of the range antenna pattern. It is modified into the output product if the following conditions are simultaneously verified: - processor capability to perform the specific calibration - calibration is explicitly requested by Processing Request File (or, if card is not allowed, if calibration is implicit into specification of output product) - calibration status retrieved from the input product Set to invalid value in the case of mosaicked DEM	Root	String			a	m	x	m	x	x			x	x	a	a		
Calibration	Azimuth Antenna Pattern Compensation Geometry	Geometry used for the compensation of the azimuth antenna pattern. It is modified into the output product if the following conditions are simultaneously verified: - processor capability to perform the specific calibration - calibration is explicitly requested by Processing Request File (or, if card is not allowed, if calibration is implicit into specification of output product) - calibration status retrieved from the input product	Root	String			a	m	x	x	x	x				x	a	a		





**COSMO-SkyMed Mission
and Products Description**

Doc. N°. : ASI-CSM-PMG-NT-001
 Date : 31 May 2016
 Rev. : Issue 2
 Pag. : 74 of 151

PROGRAMMA COSMO-SkyMed

Area	Attribute name	Description	HDF5 Struc.	Data Type	Unit / ASCII repr.	RAW	SCS	DGM DSM	GEC	GTC	SPF	CRG	IPH COH	DEM	MOS	PBR	RGC	AZP	DOP	QLK
Calibration	Azimuth Antenna Pattern Gains	Antenna two-way power azimuth pattern gain values, corresponding to the Antenna Pattern angles obtainable by other specific tags	S<mm>	Double(N1)	dB	a	x	x	x	x	x	x				x	x	x		

Calien-6 36.8

 	COSMO-SkyMed Mission and Products Description	Doc. N°. : ASI-CSM-PMG-NT-001 Date : 31 May 2016 Rev. : Issue 2 Pag. : 75 of 151
PROGRAMMA COSMO-SkyMed		

Area	Attribute name	Description	HDF5 Struc.	Data Type	Unit / ASCII repr.	RAW	SCS	DGM DSM	GEC	GTC	SPF	CRG	IPH COH	DEM	MOS	PBR	RGC	AZP	DOP	QLK	
Calibration	Calibration Constant	<p>It is the Calibration Constant value (K) of the subswath.</p> <p>It includes all constant proportionality terms between the target energy in the input product and the actual backscattering of the scene.</p> <p>It excludes terms related to Range Spreading Loss, Incidence angle and Antenna Pattern compensation operators.</p> <p>The multiplier term (1/sqrt(K)) have to be</p>																			



COSMO-SkyMed Mission and Products Description

Doc. N°. : ASI-CSM-PMG-NT-001
 Date : 31 May 2016
 Rev. : Issue 2
 Pag. : 76 of 151

PROGRAMMA COSMO-SkyMed

Area	Attribute name	Description	HDF5 Struc.	Data Type	Unit / ASCII repr.	RAW	SCS	DGM DSM	GEC	GTC	SPF	CRG	IPH COH	DEM	MOS	PBR	RGC	AZP	DOP	QLK
Calibration	Calibration Constant Compensation Flag	Flag showing the application of the calibration constant. It is modified into the output product if the following conditions are simultaneously verified: - processor capability to perform the specific calibration - calibration is explicitly requested by Processing Request File (or, if card is not allowed, if calibration is implicit into specification of output product) - calibration status retrieved from the input product Set to invalid value in the case of mosaicked DEM	Root	UByte			a	m	x	m	x	x			m	x	a	a		
Calibration	Calibration Constant Estimation UTC	Calibration constant estimation date	S<mm>	String	Epoch	a	x	x	x	m	x	x				x	x	x		
Calibration	Incidence Angle Compensation Geometry	Geometry used for the compensation of the incidence angle. It is modified into the output product if the following conditions are simultaneously verified: - processor capability to perform the specific calibration - calibration is explicitly requested by Processing Request File (or, if card is not allowed, if calibration is implicit into specification of output product) - calibration status retrieved from the input product	Root	String			a	m	x	m	x	x				x	a	a		



COSMO-SkyMed Mission and Products Description

Doc. N°. : ASI-CSM-PMG-NT-001
 Date : 31 May 2016
 Rev. : Issue 2
 Pag. : 77 of 151

PROGRAMMA COSMO-SkyMed

Area	Attribute name	Description	HDF5 Struc.	Data Type	Unit / ASCII repr.	RAW	SCS	DGM DSM	GEC	GTC	SPF	CRG	IPH COH	DEM	MOS	PBR	RGC	AZP	DOP	QLK
Calibration	Incidence Angle Compensation Reference Surface	Designator of the surface used for the compensation of the incidence angle. It is modified into the output product if the following conditions are simultaneously verified: - processor capability to perform the specific calibration - calibration is explicitly requested by Processing Request File (or, if card is not allowed, if calibration is implicit into specification of output product) - calibration status retrieved from the input product Set to invalid value in the case of mosaicked DEM	Root	String			a	m	x	m	x	x			x	x	a	a		
Calibration	Range Antenna Pattern Compensation Geometry	Geometry used for the compensation of the range antenna pattern. It is modified into the output product if the following conditions are simultaneously verified: - processor capability to perform the specific calibration - calibration is explicitly requested by Processing Request File (or, if card is not allowed, if calibration is implicit into specification of output product) - calibration status retrieved																		



COSMO-SkyMed Mission and Products Description

Doc. N°. : ASI-CSM-PMG-NT-001
 Date : 31 May 2016
 Rev. : Issue 2
 Pag. : 78 of 151

PROGRAMMA COSMO-SkyMed

Area	Attribute name	Description	HDF5 Struc.	Data Type	Unit / ASCII repr.	RAW	SCS	DGM DSM	GEC	GTC	SPF	CRG	IPH COH	DEM	MOS	PBR	RGC	AZP	DOP	QLK
Calibration	Range Antenna Pattern Origin	Angular offset in degrees from range beam centre, the first value of the range antenna pattern gains is referred to.	S<mm>	Double	deg	a	x	x	x	m	x	x				x	x	x		
Calibration	Range Antenna Pattern Resolution	The angular step in degrees the values of the range antenna pattern gains are referred to.	S<mm>	Double	deg	a	x	x	x	m	x	x				x	x	x		
Calibration	Range Spreading Loss Compensation Geometry	Geometry used for the compensation of the range spreading loss. It is modified into the output product if the following conditions are simultaneously verified: - processor capability to perform the specific calibration - calibration is explicitly requested by Processing Request File (or, if card is not allowed, if calibration is implicit into specification of output product) - calibration status retrieved from the input product	Root	String			a	m	x	x	x	x				x	a	a		



COSMO-SkyMed Mission and Products Description

Doc. N°. : ASI-CSM-PMG-NT-001
 Date : 31 May 2016
 Rev. : Issue 2
 Pag. : 79 of 151

PROGRAMMA COSMO-SkyMed

Area	Attribute name	Description	HDF5 Struct.	Data Type	Unit / ASCII repr.	RAW	SCS	DGM DSM	GEC	GTC	SPF	CRG	IPH COH	DEM	MOS	PBR	RGC	AZP	DOP	QLK
Calibration	Reference Incidence Angle	Reference incidence angle (a) used at processing time (by the divisor term $\sqrt{\sin(a)}$ applied to the signal amplitude) for the normalization of the incidence angle correction. It should be univocally defined for the entire SAR access area for the cross-equalization of data acquired at different swaths. It is set to invalid value if unused. Processing algorithms oriented to image calibration (e.g. L1D processor), must remove this factor on the SAR image and set the attribute to invalid value.	Root	Double	deg		a	x	x	m	x	x				x	a	a		
Calibration	Reference Slant Range	Reference slant range R used at processing time (raised by the relevant exponent) for the normalization of the range spreading loss compensation. It should be univocally defined for the entire SAR access area for the cross-equalization of data acquired at different swaths. It is set to 1 if unused. Processing algorithms oriented to image calibration (e.g. L1D processor), must remove this factor on the SAR image and set the attribute to one.	Root	Double	m		a	x	x	m	x	x				x	a	a		
Calibration	Reference Slant Range Exponent	Exponent of the reference slant range R used on the image amplitude at processing time for the normalization of the range spreading loss compensation.	Root	Double			a	x	x	x							a	a		



COSMO-SkyMed Mission and Products Description

Doc. N°. : ASI-CSM-PMG-NT-001
 Date : 31 May 2016
 Rev. : Issue 2
 Pag. : 80 of 151

PROGRAMMA COSMO-SkyMed

Area	Attribute name	Description	HDF5 Struc.	Data Type	Unit / ASCII repr.	RAW	SCS	DGM DSM	GEC	GTC	SPF	CRG	IPH COH	DEM	MOS	PBR	RGC	AZP	DOP	QLK
Doppler	Azimuth Polynomial Reference Time	Reference azimuth time (in seconds since the annotated reference UTC) used to represent the azimuth polynomial of Doppler variation and Range spectrum central frequency For mosaicked products it is annexed only to tiles. Set to invalid value in the case of mosaicked DEM	Root T<jjj>	Double	s	a	m	x	x	x	x				x	x	m	x	m	
Doppler	Centroid vs Azimuth Time Polynomial	Coefficients of the doppler centroid azimuth polynomial coefficients (from the lower to the higher degree) For mosaicked products it is annexed only to tiles. Set to invalid value in the case of mosaicked DEM	Root T<jjj>	Double(6)	Hz/s ⁱ	a	m	x	x	x	x				x	x	m	m	m	
Doppler	Centroid vs Range Time Polynomial	Coefficients of the doppler centroid range polynomial coefficients (from the lower to the higher degree) For mosaicked products it is annexed only to tiles. Set to invalid value in the case of mosaicked DEM	Root T<jjj>	Double(6)	Hz/s ⁱ	a	m	x	x	x	x				x	x	m	m	m	
Doppler	Doppler Ambiguity Estimation Method	Identifier of the algorithm adopted for estimation of the doppler ambiguity .	Root	String		a	m	x	x	x	x	x				x	x	x		
Doppler	Doppler Centroid Estimation Method	Identifier of the algorithm adopted for estimation of the fractional part of the doppler centroid .	Root	String		a	m	x	x	x	x	x				x	m	m	m	



COSMO-SkyMed Mission and Products Description

Doc. N°. : ASI-CSM-PMG-NT-001
 Date : 31 May 2016
 Rev. : Issue 2
 Pag. : 81 of 151

PROGRAMMA COSMO-SkyMed

Area	Attribute name	Description	HDF5 Struc.	Data Type	Unit / ASCII repr.	RAW	SCS	DGM DSM	GEC	GTC	SPF	CRG	IPH COH	DEM	MOS	PBR	RGC	AZP	DOP	QLK
Doppler	Doppler Rate Estimation Method	Identifier of the algorithm adopted for estimation of the doppler rate .	Root	String		a	x	x	x	x	x	x				x	x	x		
Doppler	Doppler Rate vs Azimuth Time Polynomial	Coefficients of the doppler rate azimuth polynomial coefficients (from the lower to the higher degree) For mosaicked products it is annexed only to tiles. Set to invalid value in the case of mosaicked DEM	Root T<jjj>	Double(6)	Hz/s ⁽ⁱ⁺¹⁾	a	m	x	x	x	x				x	x	m	x	m	
Doppler	Doppler Rate vs Range Time Polynomial	Coefficients of the doppler rate range polynomial coefficients (from the lower to the higher degree) For mosaicked products it is annexed only to tiles. Set to invalid value in the case of mosaicked DEM	Root T<jjj>	Double(6)	Hz/s ⁽ⁱ⁺¹⁾	a	m	x	x	x	x				x	x	m	x	m	
Doppler	Range Polynomial Reference Time	Reference range time used to represent the range doppler polynomial For mosaicked products it is annexed only to tiles. Set to invalid value in the case of mosaicked DEM	Root T<jjj>	Double	s	a	m	x	x	x	x				x	x	m	x	m	



COSMO-SkyMed Mission and Products Description

Doc. N°. : ASI-CSM-PMG-NT-001
 Date : 31 May 2016
 Rev. : Issue 2
 Pag. : 82 of 151

PROGRAMMA COSMO-SkyMed

Area	Attribute name	Description	HDF5 Struc.	Data Type	Unit / ASCII repr.	RAW	SCS	DGM DSM	GEC	GTC	SPF	CRG	IPH COH	DEM	MOS	PBR	RGC	AZP	DOP	QLK	
Formatting	Analog Noise Reconstruction Levels	Look Up Table to be used for reconstruction of the analogue signal level from the quantized levels included into the NOISE lines of the RAW product. Equal to QNaN for unused levels	Root	Double(256)	mV	a															
Formatting	Analog Signal Reconstruction Levels	Look Up Table to be used for reconstruction of the analogue signal level from the quantized levels included into the ECHO lines of the RAW product. Equal to QNaN for unused levels	Root	Double(256)	mV	a															
Formatting	Bits per Sample	Number of bit per image sample	Root	UByte		a	a	a	a	a	a	a	a	a	a	a	a	a	a	a	
Formatting	Columns Order	Order of columns in the formatted product. The "FAR-NEAR" order is allowed only in the case of the Quick Look product.	Root	String		a	a	a	a	a	a	a	a	a	a	a	a	a	a		
Formatting	DOP Column Time Interval	Time spacing in the range direction between columns	DOP	Double	s															a	
Formatting	DOP First Column Time	Time of the first column	DOP	Double	s															a	
Formatting	DOP First Line Time	Time of the first line of the image in seconds since the annotated reference UTC	DOP	Double	s															a	
Formatting	DOP Line Time Interval	Time spacing in the azimuth direction between lines	DOP	Double	s															a	
Formatting	Equivalent Column Time Interval	Equivalent time spacing in the range direction between columns	S<mm>	Double	s	a												m	m		



COSMO-SkyMed Mission and Products Description

Doc. N°. : ASI-CSM-PMG-NT-001
 Date : 31 May 2016
 Rev. : Issue 2
 Pag. : 83 of 151

PROGRAMMA COSMO-SkyMed

Area	Attribute name	Description	HDF5 Struc.	Data Type	Unit / ASCII repr.	RAW	SCS	DGM DSM	GEC	GTC	SPF	CRG	IPH COH	DEM	MOS	PBR	RGC	AZP	DOP	QLK
Formatting	Equivalent First Column Time	Equivalent time of the first column of the data in seconds. If set to QNaN it indicates that the compensation of SWST change has not been performed and the attribute "Range First Times" must be considered. In the case of burst mode data, it is set to the minimum of the equivalent times of the bursts included into the subswath	S<mm>	Double	s	a											m	m		
Formatting	Equivalent First Line Time	Equivalent time of the first line of the data in seconds since the annotated reference UTC. In the case of burst mode data, it is set to the equivalent time of the first burst included into the subswath	S<mm>	Double	s	a											m	m		
Formatting	Equivalent Line Time Interval	Equivalent time spacing in the azimuth direction between lines	S<mm>	Double	s	a											m	m		
Formatting	Image Layers	Number of Image Layers	Root	UByte		a	x	x	x	x	x	x	x	x	x	x	x	x		
Formatting	Image Scale	Scale used for image representation	Root	String		a	a	a	a	a	a	a	a	a	a	a	a	a		
Formatting	Layover Pixel Value	Value used for representation of pixels in layover geometry	GIM	Short						a										
Formatting	Lines Order	Order of lines in the formatted product. The "LATE-EARLY" order is allowed only in the case of the Quick Look product.	Root	String		a	a	a	a	a	a	a	a	a	a	a	a	a		
Formatting	Master Zero Doppler Azimuth First Time	Time of the first line of the ot the input master image to interferometry	SBI MBI	Double	s								a	x						



COSMO-SkyMed Mission and Products Description

Doc. N°. : ASI-CSM-PMG-NT-001
 Date : 31 May 2016
 Rev. : Issue 2
 Pag. : 84 of 151

PROGRAMMA COSMO-SkyMed

Area	Attribute name	Description	HDF5 Struc.	Data Type	Unit / ASCII repr.	RAW	SCS	DGM DSM	GEC	GTC	SPF	CRG	IPH COH	DEM	MOS	PBR	RGC	AZP	DOP	QLK	
Formatting	Master Zero Doppler Azimuth Last Time	Time of the last line of the ot the input master image to interferometry	SBI MBI	Double	s								a	x							
Formatting	Master Zero Doppler Range First Time	Time of the first column of the ot the input master image to interferometry	SBI MBI	Double	s								a	x							
Formatting	Master Zero Doppler Range Last Time	Time of the last column of the ot the input master image to interferometry	SBI MBI	Double	s								a	x							
Formatting	Original Zero Doppler Azimuth First Time	Time of the first line of the input image (master/slave), before coregistration	SBI MBI	Double	s							a									
Formatting	Original Zero Doppler Azimuth Last Time	Time of the last line of the input image (master/slave), before coregistration	SBI MBI	Double	s							a									
Formatting	Original Zero Doppler Range First Time	Time of the first column of the input image (master/slave), before coregistration	SBI MBI	Double	s							a									



COSMO-SkyMed Mission and Products Description

Doc. N°. : ASI-CSM-PMG-NT-001
 Date : 31 May 2016
 Rev. : Issue 2
 Pag. : 85 of 151

PROGRAMMA COSMO-SkyMed

Area	Attribute name	Description	HDF5 Struc.	Data Type	Unit / ASCII repr.	RAW	SCS	DGM DSM	GEC	GTC	SPF	CRG	IPH COH	DEM	MOS	PBR	RGC	AZP	DOP	QLK	
Formatting	Original Zero Doppler Range Last Time	Time of the last column of the input image (master/slave), before coregistration	SBI MBI	Double	s							a									
Formatting	Quick Look Columns Order	Order of columns in the quick look layer. For quick look annexed to Level 0 product, it is conditioned by the consideration about geometric representation of the Quick Look product (see "Higher Level Products for Civilian Application: Products Specification" for details) aiming to simplify the image interpretation. For other products, it inherits the order of the full resolution layer.	QLK	String		a	a	a	a	a	a	a	a	a	a	a					x

Formatting



COSMO-SkyMed Mission and Products Description

Doc. N°. : ASI-CSM-PMG-NT-001
 Date : 31 May 2016
 Rev. : Issue 2
 Pag. : 86 of 151

PROGRAMMA COSMO-SkyMed

Area	Attribute name	Description	HDF5 Struct.	Data Type	Unit / ASCII repr.	RAW	SCS	DGM DSM	GEC	GTC	SPF	CRG	IPH COH	DEM	MOS	PBR	RGC	AZP	DOP	QLK	
Formatting	SIM Column Time Interval	Time spacing in the range direction between columns	Root	Double	s																
Formatting	SIM First Column Time	Time of the first column	Root	Double	s																
Formatting	SIM First Line Time	Time of the first line of the image in seconds since the annotated reference UTC	Root	Double	s																
Formatting	SIM Line Time Interval	Time spacing in the azimuth direction between lines	Root	Double	s																
Formatting	Slave Zero Doppler Azimuth First Time	Time of the first line of the ot the input slave image to interferometry	SBI MBI	Double	s								a	x							
Formatting	Slave Zero Doppler Azimuth Last Time	Time of the last line of the ot the input slave image to interferometry	SBI MBI	Double	s								a	x							
Formatting	Slave Zero Doppler Range First Time	Time of the first column of the ot the input slave image to interferometry	SBI MBI	Double	s								a	x							
Formatting	Slave Zero Doppler Range Last Time	Time of the last column of the ot the input slave image to interferometry	SBI MBI	Double	s								a	x							



COSMO-SkyMed Mission and Products Description

Doc. N°. : ASI-CSM-PMG-NT-001

Date :



COSMO-SkyMed Mission and Products Description

Doc. N°. : ASI-CSM-PMG-NT-001
 Date : 31 May 2016
 Rev. : Issue 2
 Pag. : 88 of 151

PROGRAMMA COSMO-SkyMed

Area	Attribute name	Description	HDF5 Struc.	Data Type	Unit / ASCII repr.	RAW	SCS	DGM DSM	GEC	GTC	SPF	CRG	IPH COH	DEM	MOS	PBR	RGC	AZP	DOP	QLK	
Identification	Acquisition Station	Acquisition Station code where product has been acquired from. Allowed values: 1100 1101 1200 1201 1300 1301 ... See GS ICD [R3] Section 6.3.3	Root	UInt 9 digits																	x
Identification	BandReductionFlag	If True indicates that this ISF is acquired in SPOT300 Mode using the band reduction Allowed values: TRUE FALSE Default FALSE	Root	String																	x
Identification	CRG Image Flag	Flag indicating if the image has been used such as Master rather than Slave in co-registration process (both in master and slave images)	Root	String								a									
Identification	Delivery Mode	Identification of the processing mode used to meet the delivery time constraints. It is strictly related to the accuracy level of the support data (in particular of the orbital data) used to originate the product	Root	String		a	x	x	x	x	x	x				x	x	x			
Identification	Downlink Start UTC	Downlink time of the first echo line of the Level 0 file used as input to generate the product	Root	String	Epoch	a	x	x	x	x	x	x				x	x	x			



COSMO-SkyMed Mission and Products Description

Doc. N°. : ASI-CSM-PMG-NT-001
 Date : 31 May 2016
 Rev. : Issue 2
 Pag. : 89 of 151

PROGRAMMA COSMO-SkyMed

Area	Attribute name	Description	HDF5 Struc.	Data Type	Unit / ASCII repr.	RAW	SCS	DGM DSM	GEC	GTC	SPF	CRG	IPH COH	DEM	MOS	PBR	RGC	AZP	DOP	QLK
Identification	Downlink Stop UTC	Downlink time of the last echo line of the Level 0 file used as input to generate the product	Root	String	Epoch	a	x	x	x	x	x	x				x	x	x		
Identification	Master Product Filename	Filename of the master product used as reference scene for coregistration. Equal to Product Filename in master one	Root	String								a								
Identification	Master Satellite ID	Satellite identifier used for the acquisition of the master image	Root	String									a	a						
Identification	Mission ID	Mission identifier	Root	String		a	x	x	x	x	x	x	x	x	x	x	x	x		
Identification	Processing Centre	Identifier of the processing centre which generated the core preprocessing step of the current product	Root	String		a	a	a	a	a	a	a	a	a	a	a	a	x	x	
Identification	Product Filename	Product file name according to the standard convention fixed in the Product Specification Document	Root	String		a	a	a	a	a	a	a	a	a	a	a	a	a		
Identification	Product Specification Document	Code of the Specification Document (including Version and Issue) where the product content and format are detailed	Root	String		a	a	a	a	a	a	a	a	a	a	a	a	a		
Identification	Product Type	Indication of the product type. Enumerated value without suffix are for internal use only.	Root	String		a	a	a	a	a	a	a	a	a	a	a	a	a	a	
Identification	Satellite ID	Satellite Identifier For mosaicked products it is annexed only to tiles. Equal to Master Satellite ID in the case of mosaicked DEM	Root T<jjj>	String		a	x	x	x	x	x	x			x	x	x	x		



COSMO-SkyMed Mission and Products Description

Doc. N°. : ASI-CSM-PMG-NT-001
 Date : 31 May 2016
 Rev. : Issue 2
 Pag. : 90 of 151

PROGRAMMA COSMO-SkyMed

Area	Attribute name	Description	HDF5 Struct.	Data Type	Unit / ASCII repr.	RAW	SCS	DGM DSM	GEC	GTC	SPF	CRG	IPH COH	DEM	MOS	PBR	RGC	AZP	DOP	QLK		
Identification	SatelliteId	Satellite Identifier Allowed values: SAR1 SAR2 SAR3 SAR4 SAR5 SAR6 SAR7 SAR8	Root	String 10char																	x	
Identification	SensorId	Sensor Identifier Allowed value: SAR	Root	String 10char																		x
Identification	Slave Satellite ID	Satellite identifier used for the acquisition of the slave image	Root	String									a	a								
Instrument	Acquisition Mode	Instrument mode enabled during acquisition For mosaicked products it is annexed only to tiles. Equal to Master Acquisition Mode in the case of mosaicked DEM	Root T<jjj>	String		a	x	x	x	x	x	x			x	x	x	x				
Instrument	Antenna Beam Code	Code of the antenna beam as it is reported in the Level 0 data.	S<mm>	Ubyte		a	x	x	x	x	x	x				x	x	x				



COSMO-SkyMed Mission and Products Description

Doc. N°. : ASI-CSM-PMG-NT-001
 Date : 31 May 2016
 Rev. : Issue 2
 Pag. : 91 of 151

PROGRAMMA COSMO-SkyMed

Area	Attribute name	Description	HDF5 Struc.	Data Type	Unit / ASCII repr.	RAW	SCS	DGM DSM	GEC	GTC	SPF	CRG	IPH COH	DEM	MOS	PBR	RGC	AZP	DOP	QLK
Instrument	Antenna Beam Elevation	Nominal elevation angle associated to the antenna beam. It represent the signed (positive sign means the beam moving to the left) offset of the nominal main lobe w.r.t. the mechanical perpendicular to the antenna, measured in the elevation plane. It is derived from a configuration table. Such angle, in conjunction with the additional elevation and azimuth steering, is used to derive the antenna electrical pointing	S<mm>	Double	deg	a	x	x	x	x	x	x				x	x	x		
Instrument	Antenna Length	Antenna length in the azimuth direction	Root	Double	m	a	x	x	x	x	x	x	x	x	x	x	x	x		
Instrument	Azimuth Beamwidth	Antenna azimuth beam width	Root	Double	deg	a	x	x	x	x	x	x				x	x	x		
Instrument	Azimuth First Time	Initial acquisition time of the burst in seconds since the annotated reference UTC, derived from the OBTE extracted from the downlinked product. Attribute updating is applicable in the case of processing of image portion starting from Level 0 data.	B<nnn>	Double	s	a	m	m	x	x	x	x				x	m	m		
Instrument	Azimuth Instrument Geometric Resolution	Theoretical azimuth geometric resolution of the data as derived from the radar parameters (that is not considering weighting and multilooking effects)	S<mm>	Double	m		a	x	x	x	x	x				x				
Instrument	Azimuth Last Time	Final acquisition time of the portion of the burst in seconds since the annotated reference UTC, derived from the OBTE extracted from the downlinked product. Attribute updating is applicable in the case of processing of image portion starting from Level 0 data.	B<nnn>	Double	s	a	m	m	x	x	x	x				x	m	m		



COSMO-SkyMed Mission and Products Description

Doc. N°. : ASI-CSM-PMG-NT-001
 Date : 31 May 2016
 Rev. : Issue 2
 Pag. : 92 of 151

PROGRAMMA COSMO-SkyMed

Area	Attribute name	Description	HDF5 Struct.	Data Type	Unit / ASCII repr.	RAW	SCS	DGM DSM	GEC	GTC	SPF	CRG	IPH COH	DEM	MOS	PBR	RGC	AZP	DOP	QLK
Instrument	Azimuth Ramp Code	Code of the azimuth scanning ramp as it is reported in the Level 0 data. The array dimension corresponds to the number of occurrences of code's changes.	B<nnn>	UByte(N13)		a	x	x	x	x	x	x				x	x	x		
Instrument	Azimuth Ramp Code Change Lines	Image Rows indexes at which the azimuth scanning ramp has been changed (within data segment) w.r.t. the corresponding values of the previous line. Line 0 is always considered as a changing line. The array dimension corresponds to the number of occurrences of code's changes.	B<nnn>	UInt(N13)		a	x	x	x	x	x	x				x	x	x		
Instrument	Azimuth Steering	Array of the Azimuth angles of the antenna beam set at the Azimuth Ramp Code Change Lines. While for the ScanSAR and StripMap case such value should be constant within the strip/burst, in the Spotlight case the array including the azimuth direction of the antenna beam due to the repointing implied by the instrument mode should be given. The array dimension corresponds to the number of occurrences of angle's changes.	B<nnn>	Double(N13)	deg	a	x	x	x	x	x	x				x	x	x		
Instrument	Beam ID	Identifier of the beam which contributes to the full swath	S<mm>	String		a	x	x	x	x	x	x				x	x	x		
Instrument	Beam Off-Nadir Angle	Angle between the main lobe of the antenna beam and the geodetic nadir, measured in acquisition geometry. It can be used for a coarse approach to the antenna pattern compensation.	S<mm>	Double	deg	a	x	x	x	x	x	x				x	x	x		





COSMO-SkyMed Mission and Products Description

Doc. N°. : ASI-CSM-PMG-NT-001
 Date : 31 May 2016
 Rev. : Issue 2
 Pag. : 93 of 151

PROGRAMMA COSMO-SkyMed

Area	Attribute name	Description	HDF5 Struct.	Data Type	Unit / ASCII repr.	RAW	SCS	DGM DSM	GEC	GTC	SPF	CRG	IPH COH	DEM	MOS	PBR	RGC	AZP	DOP	QLK
Instrument	Bursts per Subswath	Bursts per Subswath/Polarisation. Attribute updating is applicable in the case of processing of image portion starting from Level 0 data.	S<mm>	UShort		a	m	m	x	x	x	x				x	m	x		
Instrument	Calibration Pulse Azimuth Times	Array of the slow times of the Calibration Pulses in seconds since the annotated reference UTC, derived from the OBT extracted from the downlinked product. In the case of StartCal and StopCal pulses, compensated invalid lines are associated to an azimuth times equal to QNaN	CAL	Double(193) Double(N8)	s	a														
Instrument	Calibration Sampling Window Length	Sampling Window Lengths of the Periodic Calibration Data (in number of range samples) during the acquisition of the subswath.	S<mm>	UShort		a														
Instrument	Echo Sampling Window Length	Sampling Window Lengths (in number of range samples) during the acquisition of the subswath.	S<mm>	UShort		a	x	x	x	x	x	x				x	x	x		
Instrument	Elevation Ramp Code	Code of the elevation scanning ramp as it is reported in the Level 0 data. The array dimension corresponds to the number of occurrences of code's changes.	B<nnn>	UByte(N17)		a	x	x	x	x	x	x				x	x	x		
Instrument	Elevation Ramp Code Change Lines	Image Rows indexes at which the elevation scanning ramp has been changed (within data segment) w.r.t. the corresponding values of the previous line. Line 0 is always considered as a changing line. The array dimension corresponds to the number of occurrences of code's changes.	B<nnn>	UInt(N17)		a	x	x	x	x	x	x				x	x	x		

 	COSMO-SkyMed Mission and Products Description	Doc. N°. : ASI-CSM-PMG-NT-001 Date : 31 May 2016 Rev. : Issue 2 Pag. : 94 of 151
PROGRAMMA COSMO-SkyMed		

Area	Attribute name	Description	HDF5 Struc.
------	----------------	-------------	-------------



COSMO-SkyMed Mission and Products Description

Doc. N°. : ASI-CSM-PMG-NT-001
 Date : 31 May 2016
 Rev. : Issue 2
 Pag. : 95 of 151

PROGRAMMA COSMO-SkyMed

Area	Attribute name	Description	HDF5 Struc.	Data Type	Unit / ASCII repr.	RAW	SCS	DGM DSM	GEC	GTC	SPF	CRG	IPH COH	DEM	MOS	PBR	RGC	AZP	DOP	QLK	
Instrument	Master Multi-Beam ID	Identifier of the beam which contributes to the full swath (Slave image)	Root	String									a	x							
Instrument	Master PRF	Pulse Repetition Frequency of the instrument during the scene acquisition (Master image)	S<mm>	Double	Hz								a	x							
Instrument	Master Sampling Rate	Range Sampling rate of the instrument during the scene acquisition (Master image)	S<mm>	Double	Hz								a	x							
Instrument	MOS Polarisation	Common Transmit/Receive polarisation of the mosaicked tiles Set to invalid value in the case of mosaicked DEM	MBI	String											x						
Instrument	Multi-Beam ID	Identifier of the beams combined to form the full swath For mosaicked products it is annexed only to tiles. Equal to Master Multi-Beam ID in the case of mosaicked DEM	Root T<jjj>	String		a	x	x	x	x	x	x			x	x	x	x			
Instrument	Noise Data Azimuth Times	Slow times of the Noise data in seconds since the annotated reference UTC, derived from the OBT extracted from the downlinked product	NOISE	Double(N11)	s	a															
Instrument	Noise Sampling Window Length	Sampling Window Lengths of the Noise Data (in number of range samples) during the acquisition of the subswath.	S<mm>	UShort		a															
Instrument	Original Bit Quantisation	Number of quantization bits of each channel of the RAW signal at origin (i.e. before the adaptive quantisation removal)	Root	UByte		a	x	x	x	x	x	x				x	x	x			



COSMO-SkyMed Mission and Products Description

Doc. N°. : ASI-CSM-PMG-NT-001
 Date : 31 May 2016
 Rev. : Issue 2
 Pag. : 96 of 151

PROGRAMMA COSMO-SkyMed

Area	Attribute name	Description	HDF5 Struct.	Data Type	Unit / ASCII repr.	RAW	SCS	DGM DSM	GEC	GTC	SPF	CRG	IPH COH	DEM	MOS	PBR	RGC	AZP	DOP	QLK
Instrument	Polarisation	Transmit/Receive polarisation enabled during data sensing. H = Horizontal V = Vertical	S<mm>	String		a	x	x	x	x	x	x	x	x		x	x	x		
Instrument	PRF	Pulse Repetition Frequency of the instrument during the scene acquisition	S<mm>	Double	Hz	a	m	x	x	x	x	x				x	m	m		
Instrument	Radar Frequency	Radar frequency For mosaicked products it is annexed only to tiles.	Root T<jjj>	Double	Hz	a	x	x	x	x	x	x	x	x	x	x	x	x		
Instrument	Radar Wavelength	Radar wavelength For mosaicked products it is annexed only to tiles.	Root T<jjj>	Double	m	a	x	x	x	x	x	x	x	x	x	x	x	x		
Instrument	Range Chirp Length	Range chirp length	S<mm>	Double	s	a	m	x	x	x	x	x				x	m	m		
Instrument	Range Chirp Rate	Rate of the transmitted pulse. In the case of Spotlight mode, for the acquisitions where an up-chirp and a down-chirp are alternated every PRI, it represents the rate of the first echo line of the L0 data segment used to generate the product and included into it.	S<mm>	Double	Hz/s	a	m	x	x	x	x	x				x	m	m		
Instrument	Range Chirp Rate Alternation	Flag indicating if up-down chirp policy was applied during the acquisition	Root	Ubyte		a														
Instrument	Range Chirp Samples	Number of chirp samples, as derived from Range Chirp Length and Sampling Frequency	S<mm>	UShort		a	x	x	x	x	x	x				x	x	x		



COSMO-SkyMed Mission and Products Description

Doc. N°. : ASI-CSM-PMG-NT-001
 Date : 31 May 2016
 Rev. : Issue 2
 Pag. : 97 of 151

PROGRAMMA COSMO-SkyMed

Area	Attribute name	Description	HDF5 Struct.	Data Type	Unit / ASCII repr.	RAW	SCS	DGM DSM	GEC	GTC	SPF	CRG	IPH COH	DEM	MOS	PBR	RGC	AZP	DOP	QLK
Instrument	Range First Time Change Lines	Image Rows indexes (starting from 0) at which the Sampling Window Start Time has been changed (within burst) w.r.t. the corresponding values of the previous line. Line 0 of the burst is always considered as a changing line.	B<nnn>	UInt(N7)		a	x	x	x	x	x	x				x	x	x		
Instrument	Range First Times	List of times between the rising edge of the transmit pulse and the rising edge of the receiving window opened to sample the echo of the same pulse, relevant to lines included in "Range First Time Change Lines". It differs from the value of the Sampling Window Start Time annotated into the downlinked data, as it take into account the time between the rising edge of the transmit pulse and the rising edge of the sampling window within the same PRI.	B<nnn>	Double(N7)	s	a	x	x	x	x	x	x				x	x	x		
Instrument	Rank	In flight pulses	S<mm>	UByte		a	x	x	x	x	x	x				x	x	x		
Instrument	Receiver Gain	The receiver attenuation settings used during the acquisition (see also Receiver Gain Change Lines)	B<nnn>	UByte(N15)	dB	a	x	x	x	x	x	x				x	x	x		
Instrument	Receiver Gain Change Lines	Image Rows indexes at which the Receiver Gain has been changed (within burst) w.r.t. the corresponding values of the previous line. Line 0 is always considered as a changing line. The array dimension corresponds to the number of occurrences of changes.	B<nnn>	UInt(N15)		a	x	x	x	x	x	x				x	x	x		



COSMO-SkyMed Mission and Products Description

Doc. N°. : ASI-CSM-PMG-NT-001
 Date : 31 May 2016
 Rev. : Issue 2
 Pag. : 98 of 151

PROGRAMMA COSMO-SkyMed

Area	Attribute name	Description	HDF5 Struc.	Data Type	Unit / ASCII repr.	RAW	SCS	DGM DSM	GEC	GTC	SPF	CRG	IPH COH	DEM	MOS	PBR	RGC	AZP	DOP	QLK
Instrument	Reference Dechirping Time	Offset w.r.t. the range first time, of the reference time (null frequency time) of dechirping signal (used only for the Spotlight case, set to QNaN otherwise). As default, it corresponds to the range central time.	S<mm>	Double	s	a	x	x	x	x	x	x				x	x	x		
Instrument	Replica Azimuth Times	Slow times of the reconstructed replica in seconds since the annotated reference UTC, derived from the OBT extracted from the downlinked product	REPLICA	Double(N8)	s	a														
Instrument	Sampling Rate	Range Sampling rate of the instrument during the scene acquisition	S<mm>	Double	Hz	a	m	x	x	x	x	x				x	m	m		
Instrument	Slave Acquisition Mode	Instrument mode enabled during acquisition of slave image	Root	String									a	x						
Instrument	Slave Multi-Beam ID	Identifier of the beam which contributes to the full swath (Slave image)	Root	String									a	x						
Instrument	Slave PRF	Pulse Repetition Frequency of the instrument during the scene acquisition (Slave Image)	S<mm>	Double	Hz								a	x						
Instrument	Slave Sampling Rate	Range Sampling rate of the instrument during the scene acquisition (Slave image)	S<mm>	Double	Hz								a	x						
Instrument	Subswaths Number	Number of subswaths included in scene	Root	UByte		a	x	x	x	x	x	x				x	x	x		
Instrument	Synthetic Aperture Duration	Duration of the synthetic aperture at the central slant range	S<mm>	Double	s	a	x	x	x	x	x	x				x	x	x		
PCD	ASLR Null Pixel	Percentage of null intensity pixel of the output image in the adaptively weighted image (estimated only on valid pixels)	Root	Double												a				



**COSMO-SkyMed Mission
and Products Description**

Doc. N°. : ASI-CSM-PMG-NT-001
 Date : 31 May 2016
 Rev. : Issue 2
 Pag. : 99 of 151

PROGRAMMA COSMO-SkyMed

Area	Attribute name	Description	HDF5 Struc.	Data Type	Unit / ASCII repr.	RAW	SCS	DGM DSM	GEC	GTC	SPF	CRG	IPH COH	DEM	MOS	PBR	RGC	AZP	DOP	QLK
PCD	ASLR Null Pixel Original	Percentage of null intensity pixel in the original Image (estimated only on valid pixels)	Root	Double												a				
PCD	ASLR Signal Shift	The average signal space shifts	Root	Double																



COSMO-SkyMed Mission and Products Description

Doc. N°. : ASI-CSM-PMG-NT-001
 Date : 31 May 2016
 Rev. : Issue 2
 Pag. : 100 of 151

PROGRAMMA COSMO-SkyMed

Area	Attribute name	Description	HDF5 Struct.	Data Type	Unit / ASCII repr.	RAW	SCS	DGM DSM	GEC	GTC	SPF	CRG	IPH COH	DEM	MOS	PBR	RGC	AZP	DOP	QLK	
PCD	CRG Baseline	For each slave: Baseline orthogonal and parallel components w.r.t. the line of sight estimated at the image center Set to invalid value in Master Set to invalid value in mosaiked products not representing a DEM	SBI MBI T<:jij>	Double[2]	m							a	x	x	x						
PCD	CRG GCP Cross-correlation SNR	For each slave: for each GCP the ratio between the intensity of the peak of the cross-correlation matrix and the mean value of the intensity of the matrix itself: $q_i = I_i(\max) / \langle I_i \rangle$ Set to invalid value for GCPs outside the overlapping area. Set to invalid value in Master	SBI MBI	Double(N19, N18)								a									
PCD	CRG GCPs Coherence	For each slave: for each GCP the maximum value of the coherence on the matrix Set to invalid value for GCPs outside the overlapping area. Set to invalid value in Master	SBI MBI	Double(N19, N18)								a									
PCD	CRG GCPs Flag	For each slave: Flag array of valid GCPs Set to -1 for GCPs outside the overlapping area. Set to invalid value in Master	SBI MBI	Short(N19, N18)								a									
PCD	CRG GCPs in Master	Matrix of GCP Row/Col coordinates in master image (only in master image) before possible cut Set to invalid value in Slave	SBI MBI	Double(N19, N18, 2]								a									



COSMO-SkyMed Mission and Products Description

Doc. N°. : ASI-CSM-PMG-NT-001
 Date : 31 May 2016
 Rev. : Issue 2
 Pag. : 101 of 151

PROGRAMMA COSMO-SkyMed

Area	Attribute name	Description	HDF5 Struct.	Data Type	Unit / ASCII repr.	RAW	SCS	DGM DSM	GEC	GTC	SPF	CRG	IPH COH	DEM	MOS	PBR	RGC	AZP	DOP	QLK	
PCD	CRG GCPs in Slave	For each slave: Matrix of GCP Row/Col coordinates in slave image before coregistration and possible cut Set to invalid value for GCPs outside the overlapping area. Set to invalid value in Master	SBI MBI	Double[N19, N18, 2]								a									
PCD	CRG GCPs Residuals	For each slave: Differences between the evaluated row,col coordinates for each GCP of the slave and the ones obtained by applying the warping function to the valid master GCP Set to invalid value for GCPs outside the overlapping area. Set to invalid value in Master	SBI MBI	Double(N19, N18,2)								a									
PCD	CRG GCPs Residuals Mean	For each slave: Mean of geometric residuals of GCPs coregistration Set to invalid value in Master	SBI MBI	Double(2)								a	x	x							
PCD	CRG GCPs Residuals Standard Deviation	For each slave: Standard deviation of geometric residuals of GCPs coregistration Set to invalid value in Master	SBI MBI	Double(2)								a	x	x							



COSMO-SkyMed Mission and Products Description

Doc. N°. : ASI-CSM-PMG-NT-001
 Date : 31 May 2016
 Rev. : Issue 2
 Pag. : 102 of 151

PROGRAMMA COSMO-SkyMed

Area	Attribute name	Description	HDF5 Struc.	Data Type	Unit / ASCII repr.	RAW	SCS	DGM DSM	GEC	GTC	SPF	CRG	IPH COH	DEM	MOS	PBR	RGC	AZP	DOP	QLK	
PCD	CRG Master to Slave Warp Matrix	For each slave: Warp matrix converting master Row/Col indexes to the slave's ones in Coregistration process. Array is always dimensioned to represent a 3rd degree warp transformation; some field could be set to zero as function of the degree actually used. If R and C (resp. R' and C') represent Row-Col indexes in the master (resp. slave) reference, the first row of the matrix includes coefficients a_i ($i=0, \dots, 9$) such that $R' = a_0 + a_1 \cdot R + a_2 \cdot C + a_3 \cdot R^2 + a_4 \cdot R \cdot C + a_5 \cdot C^2 + a_6 \cdot R^3 + a_7 \cdot R^2 \cdot C + a_8 \cdot R \cdot C^2 + a_9 \cdot C^3$ The second row of the matrix includes coefficients b_i ($i=0, \dots, 9$) such that $C' = b_0 + b_1 \cdot R + b_2 \cdot C + b_3 \cdot R^2 + b_4 \cdot R \cdot C + b_5 \cdot C^2 + b_6 \cdot R^3 + b_7 \cdot R^2 \cdot C + b_8 \cdot R \cdot C^2 + b_9 \cdot C^3$	SBI MBI	Double[2, 10]								a									
PCD	CRG Overlapping Percentage	For each slave: extension (as percentage of the master coverage) of the overlapping zone between the slave and the master Set to invalid value in Master	SBI MBI	Double								a									



Doc. N°.

COSMO-SkyMed Mission and Products Description





COSMO-SkyMed Mission and Products Description

Doc. N°. : ASI-CSM-PMG-NT-001
 Date : 31 May 2016
 Rev. : Issue 2
 Pag. : 104 of 151

PROGRAMMA COSMO-SkyMed

Area	Attribute name	Description	HDF5 Struc.	Data Type	Unit / ASCII repr.	RAW	SCS	DGM DSM	GEC	GTC	SPF	CRG	IPH COH	DEM	MOS	PBR	RGC	AZP	DOP	QLK
PCD	Doppler Centroid Confidence Measure	Normalized confidence measure of doppler centroid. A value of zero means poor confidence.	Root	Double		a	m	x	x	x	x	x				x	m	m	m	
PCD	Doppler Centroid Estimation Accuracy	Standard deviation in the estimation of doppler centroid.	Root	Double	Hz	a	m	x	x	x	x	x				x	m	m	m	
PCD	Doppler Rate Confidence Measure	Normalized confidence measure of doppler rate. A value of zero means poor confidence.	Root	Double		a	x	x	x	x	x	x				x	x	x		
PCD	Doppler Rate Estimation Accuracy	Standard deviation in the estimation of doppler rate.	Root	Double	Hz/s	a	x	x	x	x	x	x				x	x	x		
PCD	Image Max	Image maximum value estimated separately on each channel of data excluding saturated pixels; second element of the array set to zero in the case of real data. Not estimated (hence set to QNaN) in the case of intermediate products.	SBI MBI	Double(2)			a	a	a	a	a	a	a	a	a	a				
PCD	Image Mean	Image mean value estimated separately on each channel of data; second element of the array set to zero in the case of real data. Not estimated (hence set to QNaN) in the case of intermediate products.	SBI MBI	Double(2)			a	a	a	a	a	a	a	a	a	a				

 	COSMO-SkyMed Mission and Products Description	Doc. N°. : ASI-CSM-PMG-NT-001 Date : 31 May 2016 Rev. : Issue 2 Pag. : 105 of 151
PROGRAMMA COSMO-SkyMed		

Area	Attribute name	Description	HDF5 Struc.	Data Type	Unit / ASCII repr.	RAW	SCS	DGM DSM	GEC	GTC	SPF	CRG	IPH COH	DEM	MOS	PBR	RGC	AZP	DOP	QLK	
PCD	Image Min	Image minimum value estimated separately on each channel of i-USI n inglue5-6(e)ix4(r																			



COSMO-SkyMed Mission and Products Description

Doc. N°. : ASI-CSM-PMG-NT-001
 Date : 31 May 2016
 Rev. : Issue 2
 Pag. : 106 of 151

PROGRAMMA COSMO-SkyMed

Area	Attribute name	Description	HDF5 Struc.	Data Type	Unit / ASCII repr.	RAW	SCS	DGM DSM	GEC	GTC	SPF	CRG	IPH COH	DEM	MOS	PBR	RGC	AZP	DOP	QLK	
PCD	Image to Simulation Warp Matrix	In geocoding process, it represents the warp matrix converting Row/Col indexes of the original SAR image to the ones of the simulated SAR scene. Array is always dimensioned to represent a 1st degree warp transformation; some field could be set to zero as function of the degree actually used. If R and C (resp. R' and C') represent Row-Col indexes in the original image (resp. simulated image) reference, the first row of the matrix includes coefficients a_i ($i=0, \dots, 2$) such that $R' = a_0 + a_1 \cdot R + a_2 \cdot C$ The second row of the matrix includes coefficients b_i ($i=0, \dots, 2$) such that $C' = b_0 + b_1 \cdot R + b_2 \cdot C$	Root	Double[2, 3]						a											
PCD	Image UnderSaturated Percentage	Percentage of Undersaturated pixels in the image estimated separately on each channel of data; second element of the array set to zero in the case of real data. Not estimated (hence set to QNaN) in the case of intermediate products.	SBI MBI	Double(2)			a	a	a	a	a	a				a					
PCD	Layover Pixel Percentage	Percentage of pixels in layover geometry with respect to the pixel of the scene (hence not considering invalid zones at the image borders deriving from image reprojection)	GIM	Double						a											



COSMO-SkyMed Mission and Products Description

Doc. N°. : ASI-CSM-PMG-NT-001
 Date : 31 May 2016
 Rev. : Issue 2
 Pag. : 107 of 151

PROGRAMMA COSMO-SkyMed

Area	Attribute name	Description	HDF5 Struc.	Data Type	Unit / ASCII repr.	RAW	SCS	DGM DSM	GEC	GTC	SPF	CRG	IPH COH	DEM	MOS	PBR	RGC	AZP	DOP	QLK	
PCD	MissingLinesPercentage	Missing Lines percentage	Root	UInt 3digit																	x
PCD	NumberOfGaps	Number of Gaps	Root	UInt 9digit																	x
PCD	POD Initial Position Accuracy	Quality index of the Precise Orbit Determination. It indicates the accuracy on the initial position of the propagation model. Further details in "POD Data Specification" document. Set to QNaN in the case POD Product Category is equal to "DOWNLINKED"	Root	Double	m	a	x	x	m	m	x	x				x	x	x			
PCD	POD Overlap Position Accuracy	Quality index of the Precise Orbit Determination. It indicates the accuracy of the platform position in the overlapping arcs. Further details in "POD Data Specification" document. Set to QNaN in the case POD Product Category is equal to "DOWNLINKED"	Root	Double	m	a	x	x	m	m	x	x				x	x	x			



COSMO-SkyMed Mission and Products Description

Doc. N°. : ASI-CSM-PMG-NT-001
 Date : 31 May 2016
 Rev. : Issue 2
 Pag. : 108 of 151

PROGRAMMA COSMO-SkyMed

Area	Attribute name	Description	HDF5 Struc.	Data Type	Unit / ASCII repr.	RAW	SCS	DGM DSM	GEC	GTC	SPF	CRG	IPH COH	DEM	MOS	PBR	RGC	AZP	DOP	QLK
PCD	POD Product Category	<p>Quality index of the Precise Orbit Determination process. It indicates the level of accuracy of the orbital data annexed to the product. DOWNLINKED indicates the orbital data annexed to the Level 0 data as they are downlinked from the spacecraft PROPAGATED indicates the orbital data obtained by propagating restituted orbits after the end of the analyzed data arc FILTERED indicates the orbital data obtained by filtering the on board navigation solution RESTITUTED indicates the orbital data based on the GPS data acquired by on board GPS and the GPS ground network (CSK fiducial network and/or IGS network). Such attribute is strictly related to the product delivery mode (Fast Delivery rather than Standard Delivery). Fast Delivery mode implies usage of DOWNLINKED or PROPAGATED orbit Standard Delivery mode implies usage of FILTERED or RESTITUTED orbit For mosaicked products it is annexed only to tiles.</p>	Root T<jjj>	String	a	x	x	x	x	x	x				x	x	x	x		



COSMO-SkyMed Mission and Products Description

Doc. N°. : ASI-CSM-PMG-NT-001
 Date : 31 May 2016
 Rev. : Issue 2
 Pag. : 109 of 151

PROGRAMMA COSMO-SkyMed

Area	Attribute name	Description	HDF5 Struct.	Data Type	Unit / ASCII repr.	RAW	SCS	DGM DSM	GEC	GTC	SPF	CRG	IPH COH	DEM	MOS	PBR	RGC	AZP	DOP	QLK
PCD	POD Quality Flag	Quality index of the Precise Orbit Determination process performed on ground, extracted from the orbital product Set to "N/A" in the case of downlinked orbit are used For mosaicked products it is annexed only to tiles.	Root T<jjj>	String		a	x	x	m	m	x	x			x	x	x	x		
PCD	RAW Bias	Bias of RAW data; two samples for the In-Phase and Quadrature signal (I-Q) estimated on valid lines of the block	B<nnn>	Double(N9, N10, 2)		a	x	x	x	x	x	x				x	x	x		
PCD	RAW Gain Imbalance	Gain imbalance of the I and Q channel of the RAW data estimated on valid lines of the block	B<nnn>	Double(N9, N10)		a	x	x	x	x	x	x				x	x	x		
PCD	RAW I/Q Normality	Measure of the Gaussian properties of I and Q channels distribution	B<nnn>	Double(N9, N10, 2)	deg	a	x	x	x	x	x	x				x	x	x		
PCD	RAW I/Q Orthogonality	Phase difference (orthogonality) between I and Q channels of RAW data estimated on valid lines	B<nnn>	Double(N9, N10)	deg	a	x	x	x	x	x	x				x	x	x		
PCD	RAW Missing Blocks Start Lines	Image Lines' indexes at which a readjusted (e.g. by zero filling) missing block starts. If no missing blocks occur in data, a zeroed one-element array is used for this tag and for "RAW Missing Lines per Block" one.	B<nnn>	UInt(N16)		a	x	x	x	x	x	x				x	x	x		
PCD	RAW Missing Lines per Block	Number of missing lines within each readjusted missing block If no missing blocks occur in data, a zeroed one-element array is used for this tag and for "RAW Missing Blocks Start Lines" one.	B<nnn>	UShort(N16)		a	x	x	x	x	x	x				x	x	x		



COSMO-SkyMed Mission and Products Description

Doc. N°. : ASI-CSM-PMG-NT-001
 Date : 31 May 2016
 Rev. : Issue 2
 Pag. : 110 of 151

PROGRAMMA COSMO-SkyMed

Area	Attribute name	Description	HDF5 Struc.	Data Type	Unit / ASCII repr.	RAW	SCS	DGM DSM	GEC	GTC	SPF	CRG	IPH COH	DEM	MOS	PBR	RGC	AZP	DOP	QLK
PCD	RAW Missing Lines Percentage	Percentage of missing lines to total lines of the burst	B<nnn>	Double		a	x	x	x	x	x	x				x	x	x		
PCD	RAW OverSaturated Percentage	Percentage of RAW Oversaturated; two samples for the In-Phase and Quadrature signal (I-Q)	B<nnn>	Double(2)		a	x	x	x	x	x	x				x	x	x		
PCD	RAW Phase Uniformity	Measure of the uniform properties of phase distribution of the RAW data	B<nnn>	Double(N9, N10)	deg	a	x	x	x	x	x	x				x	x	x		
PCD	RAW Standard Deviation	Standard dev of RAW data; two samples for the In-Phase and Quadrature signal (I-Q)	B<nnn>	Double(N9, N10, 2)		a	x	x	x	x	x	x				x	x	x		
PCD	RAW UnderSaturated Percentage	Percentage of RAW Undersaturated; two samples for the In-Phase and Quadrature signal (I-Q)	B<nnn>	Double(2)		a	x	x	x	x	x	x				x	x	x		
PCD	Replica Geometric Resolution	Array including geometric resolution of each reconstructed replica	REPLICA	Double(N8)		a														
PCD	Replica ISLR	Array including ISLR of each reconstructed replica	REPLICA	Double(N8)		a														
PCD	Replica PSLR	Array including left and right PSLR of each reconstructed replica	REPLICA	Double(N8, 2)		a														
PCD	Replica Shape 10dB/-3dB	Aperture ratio of main lobe of reconstructed replica measured at -10 dB and -3dB	REPLICA	Double(N8)		a														
PCD	Replica Shape 6dB/-3dB	Aperture ratio of main lobe of reconstructed replica measured at -10 dB and -3dB	REPLICA	Double(N8)		a														



**COSMO-SkyMed Mission
and Products Description**

Doc. N°. : ASI-CSM-PMG-NT-001
Date : 31 May 2016
Rev. : Issue 2
Pag. : 111 of 151

PROGRAMMA COSMO-SkyMed

Area	Attribute name	Description	HDF5 Struc.	Data Type	Unit / ASCII repr.	RAW	SCS	DGM DSM	GEC	GTC	SPF	CRG	IPH COH	DEM	MOS	PBR	RGC	AZP	DOP	QLK	
PCD	Replica SSLR	Array including left and right SSLR of each reconstructed replica	REPLICA	Double(N8, 2)		a															
PCD	Shadowing Pixel Percentage	Percentage of pixels in shadowing geometry with respect to the pixel of the scene (hence not considering invalid zones at the image borders deriving from image reprojection)	GIM	Double						a											
PCD	SPF Mean Intensity Ratio	Average of the Intensity Ratio between input and speckle filtered image Set to QNaN in the case speckle filtering is not applied.	Root	Double				a	x	x	a										
PCD	SPF Standard Deviation Intensity Ratio	Standard Deviation of the intensity ratio between input and speckle filtered image Set to QNaN in the case speckle filtering is not applied.	Root	Double				a	x	x	a										
PCD	SPF Target Contrast	The 1-st column represents the Target Contrast values detected for each threshold defined (in terms of in unit of standard deviation from the mean value) in the 2-nd column. Set to [QNaN, QNaN] in the case speckle filtering is not applied.	Root	Double[N14, 2]				a	x	x	a										
PCD	SPF Targets	Number of pixels above the target contrast threshold Set to 0 in the case speckle filtering is not applied.	Root	ULong(N14)				a	x	x	a										



COSMO-SkyMed Mission and Products Description

Doc. N°. : ASI-CSM-PMG-NT-001
 Date : 31 May 2016
 Rev. : Issue 2
 Pag. : 112 of 151

PROGRAMMA COSMO-SkyMed

Area	Attribute name	Description	HDF5 Struc.	Data Type	Unit / ASCII repr.	RAW	SCS	DGM DSM	GEC	GTC	SPF	CRG	IPH COH	DEM	MOS	PBR	RGC	AZP	DOP	QLK
Platform	Attitude Quaternions	Array of quaternions representing the satellite attitude associated to the annotated times. They are stored in notation (q1, q2, q3, q4) where q1 represents the so-called "real" part and (q2, q3, q4), is the so-called "imaginary" part of the quaternion For mosaicked products it is annexed only to tiles.	Root T<jjj>	Double(N12, 4)		a	x	x	x	x	x	x			x	x	x	x		
Platform	Attitude Times	Array of times (in seconds since the annotated reference UTC) at which the satellite attitude is supplied For mosaicked products it is annexed only to tiles.	Root T<jjj>	Double(N12)	s	a	x	x	x	x	x	x			x	x	x	x		
Platform	ECEF Satellite Acceleration	Satellite Acceleration in Earth Centred - Earth Fixed Cartesian coordinate system, corresponding to the annotated times	Root	Double(N6, 3)	m/s ²	a	x	x	x	x	x	x				x	x	x		
Platform	ECEF Satellite Position	Satellite Position in Earth Centred - Earth Fixed Cartesian coordinate system, corresponding to the annotated times Equal to Master ECEF Satellite Position in the case of mosaicked DEM For mosaicked products it is annexed only to tiles.	Root T<jjj>	Double(N6, 3)	m	a	x	x	x	x	x	x			x	x	x	x		
Platform	ECEF Satellite Velocity	Satellite Velocity in Earth Centred - Earth Fixed Cartesian coordinate system, corresponding to the annotated times Equal to Master ECEF Satellite Velocity in the case of mosaicked DEM For mosaicked products it is annexed only to tiles.	Root T<jjj>	Double(N6, 3)	m/s	a	x	x	x	x	x	x			x	x	x	x		



COSMO-SkyMed Mission and Products Description

Doc. N°. : ASI-CSM-PMG-NT-001
 Date : 31 May 2016
 Rev. : Issue 2
 Pag. : 113 of 151

PROGRAMMA COSMO-SkyMed

Area	Attribute name	Description	HDF5 Struc.	Data Type	Unit / ASCII repr.	RAW	SCS	DGM DSM	GEC	GTC	SPF	CRG	IPH COH	DEM	MOS	PBR	RGC	AZP	DOP	QLK
Platform	Inertial Reference Frame ID	Identifier of the inertial reference frame	Root	String		a	x	x	x	x	x	x				x	x	x		
Platform	Inertial Satellite Acceleration	Satellite Acceleration in Inertial Reference Frame, corresponding to the annotated times	Root	Double(N6, 3)	m/s	a	x	x	x	x	x	x				x	x	x		
Platform	Inertial Satellite Position	Satellite Position in Inertial Reference Frame, corresponding to the annotated times	Root	Double(N6, 3)	m	a	x	x	x	x	x	x				x	x	x		
Platform	Inertial Satellite Velocity	Satellite Velocity in Inertial Reference Frame, corresponding to the annotated times	Root	Double(N6, 3)	m/s	a	x	x	x	x	x	x				x	x	x		
Platform	Master ECEF Satellite Position	Satellite Position relevant to the Master image acquisition, in Earth Centred - Earth Fixed Cartesian coordinate system, corresponding to the annotated times	Root	Double(N6, 3)	m								a	x						
Platform	Master ECEF Satellite Velocity	Satellite Velocity relevant to the Master image acquisition, in Earth Centred - Earth Fixed Cartesian coordinate system, corresponding to the annotated times	Root	Double(N6, 3)	m/s								a	x						
Platform	Master State Vectors Times	Array of times (in seconds since the annotated reference UTC) at which the satellite state vectors relevant to the Master image (Position, Velocity, Attitude and Angular Rate) are supplied	Root	Double(N6)	s								a	x						



COSMO-SkyMed Mission and Products Description

Doc. N°. : ASI-CSM-PMG-NT-001
 Date : 31 May 2016
 Rev. : Issue 2
 Pag. : 114 of 151

PROGRAMMA COSMO-SkyMed

Area	Attribute name	Description	HDF5 Struc.	Data Type	Unit / ASCII repr.	RAW	SCS	DGM DSM	GEC	GTC	SPF	CRG	IPH COH	DEM	MOS	PBR	RGC	AZP	DOP	QLK
Platform	Number of State Vectors	Number of annotated state vectors (N6). Products originated from orbital data derived from POD, will include fifteen state vectors extracted from the orbital product (not having recourse to interpolation), equally distributed around the centre time of the SAR product. Products originated from downlinked orbital data will include all state vectors extracted from RAW data	Root	UShort		a	x	x	x	x	x	x				x	x	x		
Platform	Orbit Direction	Ascending or descending orbit designator, as it is derived from the third component of the ECEF satellite velocity at scene centre time	Root	String		a	x	x	x	x	x	x	x			x	x	x		
Platform	PassDirection	Flight direction of the Satellite (ascending /descending / both). Allowed values: A Ascending D Descending B Both	Root	String 1char																x
Platform	Pitch Rate	Satellite Pitch angular rate corresponding to the annotated times.	Root	Double(N12)	deg/s	a	x	x	x	x	x	x				x	x	x		
Platform	Roll Rate	Satellite Roll angular rate corresponding to the annotated times.	Root	Double(N12)	deg/s	a	x	x	x	x	x	x				x	x	x		
Platform	Satellite Height	Satellite ellipsoidal height measured at the image central azimuth time	Root	Double	m	a	x	x	x	x	x	x				x	x	x		
Platform	Slave ECEF Satellite Position	Satellite Position relevant to the Slave image acquisition, in Earth Centred - Earth Fixed Cartesian coordinate system, corresponding to the annotated times	Root	Double(N6, 3)	m								a	x						



COSMO-SkyMed Mission and Products Description

Doc. N°. : ASI-CSM-PMG-NT-001
 Date : 31 May 2016
 Rev. : Issue 2
 Pag. : 115 of 151

PROGRAMMA COSMO-SkyMed

Area	Attribute name	Description	HDF5 Struct.	Data Type	Unit / ASCII repr.	RAW	SCS	DGM DSM	GEC	GTC	SPF	CRG	IPH COH	DEM	MOS	PBR	RGC	AZP	DOP	QLK	
Platform	Slave ECEF Satellite Velocity	Satellite Velocity relevant to the Slave image acquisition, in Earth Centred - Earth Fixed Cartesian coordinate system, corresponding to the annotated times	Root	Double(N6, 3)	m/s								a	x							
Platform	Slave State Vectors Times	Array of times (in seconds since the annotated reference UTC) at which the satellite state vectors relevant to the Slave image (Position, Velocity, Attitude and Angular Rate) are supplied	Root	Double(N6)	s								a	x							
Platform	State Vectors Times	Array of times (in seconds since the annotated reference UTC) at which the satellite state vectors (Position, Velocity) are supplied Equal to Master State Vectors Times in the case of mosaicked DEM For mosaicked products it is annexed only to tiles.	Root T<jjj>	Double(N6)	s	a	x	x	x	x											

142 5 0.480x



COSMO-SkyMed Mission and Products Description

Doc. N°. : ASI-CSM-PMG-NT-001
 Date : 31 May 2016
 Rev. : Issue 2
 Pag. : 116 of 151

PROGRAMMA COSMO-SkyMed

Area	Attribute name	Description	HDF5 Struc.	Data Type	Unit / ASCII repr.	RAW	SCS	DGM DSM	GEC	GTC	SPF	CRG	IPH COH	DEM	MOS	PBR	RGC	AZP	DOP	QLK
Processing	ASLR Direction	Direction (range, azimuth or both) where is applied the Adaptive Side Lobe Reduction; in the 2 dimensional case, three options are available: apply the 1 dimensional to the Range direction the to the Azimuth one (2DRgAz); vice-versa (2DAzRg); or combined (2D) , either coupled or uncoupled	Root	String												a				
Processing	ASLR Number of Signals	The number of signals considered in the signal to clutter average and the signal shifts quality indices	Root	UShort												a				
Processing	ASLR Oversampling Azimuth Factor	The upsampling factor (ratio of the output to the original image size) in the azimuth direction for, before the Adaptive Side Lobe Reduction; 1 means no upsampling	Root	Double												a				
Processing	ASLR Oversampling Range Factor	The upsampling factor (ratio of the output to the original image size) in the range direction for, before the Adaptive Side Lobe Reduction; 1 means no upsampling	Root	Double												a				
Processing	ASLR Range Kernel Size	The size of the kernel used in the Adaptive Side Lobe Reduction, in the range direction is given by two times the ASR Rg Kernel Size plus 1 pixels	Root	UShort												a				
Processing	ASLR Software Version	Version of the Adaptive Side Lobe Reduction software	Root	String	n.m											a				
Processing	Azimuth Bandwidth per Look	Bandwidth per look in azimuth used for the multilooked image formation	S<mm>	Double	Hz			a	x	x	x	x								
Processing	Azimuth Focusing Bandwidth	The Doppler bandwidth used at the single-look generation time	S<mm>	Double	Hz		a	x	x	x	x	x				x		a		



COSMO-SkyMed Mission and Products Description

Doc. N°. : ASI-CSM-PMG-NT-001
 Date : 31 May 2016
 Rev. : Issue 2
 Pag. : 117 of 151

PROGRAMMA COSMO-SkyMed

Area	Attribute name	Description	HDF5 Struc.	Data Type	Unit / ASCII repr.	RAW	SCS	DGM DSM	GEC	GTC	SPF	CRG	IPH COH	DEM	MOS	PBR	RGC	AZP	DOP	QLK
Processing	Azimuth Focusing Transition Bandwidth	The transition bandwidth in azimuth used at the single-look generation time	S<mm>	Double	Hz		a	x	x	x	x	x				x		a		
Processing	Azimuth Focusing Weighting Coefficient	Azimuth coefficients used for the weighting function applied at the focusing time to the processed portion of the full band	Root	Double			a	x	x	x	x	x				x		a		
Processing	Azimuth Focusing Weighting Function	Type of matched filter windowing in the azimuth direction at the focusing time	Root	String			a	x	x	x	x	x				x		a		
Processing	Azimuth Multilooking Transition Bandwidth	The transition bandwidth in azimuth used at the multilooked image formation	S<mm>	Double	Hz			a	x	x	x	x								
Processing	Azimuth Multilooking Weighting Coefficient	Azimuth coefficients used for the weighting function applied at the multilooking time to each look	Root	Double				a	x	x	x	x								
Processing	Azimuth Multilooking Weighting Function	Type of matched filter windowing in the azimuth direction at the multilooking time	Root	String				a	x	x	x	x								
Processing	Azimuth Processing Number of Looks	Number of processing azimuth looks	Root	UByte			a	m	x	x	m	x	m			x				
Processing	Baseline Calibration Flag	Flag indicating if the unwrapping has been applied (interferometric DEM)	Root	UByte										a						



COSMO-SkyMed Mission and Products Description

Doc. N°. : ASI-CSM-PMG-NT-001
 Date : 31 May 2016
 Rev. : Issue 2
 Pag. : 118 of 151

PROGRAMMA COSMO-SkyMed

Area	Attribute name	Description	HDF5 Struct.	Data Type	Unit / ASCII repr.	RAW	SCS	DGM DSM	GEC	GTC	SPF	CRG	IPH COH	DEM	MOS	PBR	RGC	AZP	DOP	QLK	
Processing	Beam Mosaicking Policy	Algorithm used for merging of overlapped beams (used only for ScanSAR mode, set to "N/A" otherwise)	Root	String				a	x	x	x	x			x						
Processing	Column Spacing	Spacing among columns of the products. It is expressed in degrees in the case of GEODETIC projection, in meters otherwise.	SBI MBI	Double	m deg		a	m	m	m	x	m	m	m	m	m					
Processing	Column Time Interval	Time spacing in the range direction between columns Set to invalid value in the case of ground projected products	SBI MBI	Double	s		a					x	m			m					
Processing	CRG Coarse GCP Tolerance	Threshold for setting valid GCP after the coarse co-registration (both in master and slave images)	Root	Double								a									
Processing	CRG Coarse Interpolation Factor	Coarse Registration Interpolation Factor in range and azimuth direction (both in master and slave images)	Root	Double(2)								a									
Processing	CRG Coarse Window Size	Coarse Registration Window size in range and azimuth direction (both in master and slave images)	Root	UShort(2)								a									
Processing	CRG Coherence Tolerance	Threshold for setting valid GCP after the fine co-registration (both in master and slave images)	Root	Double								a									
Processing	CRG Coherence Window Size	Coherence Window size (both in master and slave images)	Root	Ushort(2)								a									



COSMO-SkyMed Mission and Products Description

Doc. N°. : ASI-CSM-PMG-NT-001
 Date : 31 May 2016
 Rev. : Issue 2
 Pag. : 119 of 151

PROGRAMMA COSMO-SkyMed

Area	Attribute name	Description	HDF5 Struc.	Data Type	Unit / ASCII repr.	RAW	SCS	DGM DSM	GEC	GTC	SPF	CRG	IPH COH	DEM	MOS	PBR	RGC	AZP	DOP	QLK	
Processing	CRG Cubic Convolution Coefficient	Convolution Coefficient used in cubic interpolation performed on slave in the co-registration (both in master and slave images)	Root	Double								a									
Processing	CRG Fine Window Size	Fine Registration Window size in range and azimuth direction (both in master and slave images)	Root	UShort(2)								a									
Processing	CRG GCPs Selection Mode	Designator of the selection mode of GCPs for co-registration (both in master and slave images)	Root	String								a									
Processing	CRG Interpolation Inverse Tolerance	The length of lookup tables used to speed up the sinc interpolation (both in master and slave images). High values give a good accuracy at the expense of an increased memory requirement. The accuracy that can be achieved is given by the reciprocal of this parameter, i.e. the default value (1000) gives an accuracy of 1/1000 of a pixel.	Root	Double								a									
Processing	CRG Interpolator ID	Designator of the type interpolation method performed on slave in the co-registration (both in master and slave images)	Root	String								a									
Processing	CRG Level ID	Designator of the type of performed co-registration (both in master and slave images)	Root	String								a									
Processing	CRG Number of GCPs	Number of GCPs in column (in the following N18) and row (in the following N19) directions	Root	UInt(2)								a									
Processing	CRG Overlap Type	Designator of the type of rectangular zone on which the co-registration is performed (both in master and slave images)	Root	String								a									



COSMO-SkyMed Mission and Products Description

Doc. N°. : ASI-CSM-PMG-NT-001
 Date : 31 May 2016
 Rev. : Issue 2
 Pag. : 120 of 151

PROGRAMMA COSMO-SkyMed

Area	Attribute name	Description	HDF5 Struc.	Data Type	Unit / ASCII repr.	RAW	SCS	DGM DSM	GEC	GTC	SPF	CRG	IPH COH	DEM	MOS	PBR	RGC	AZP	DOP	QLK
Processing	CRG Sinc Interpolator Length	Filter length used in sinc interpolation performed on slave in the co-registration: it is the filter size in row, col (both in master and slave images)	Root	UShort(2)								a								
Processing	CRG Software Version	Version of the co-registration software (both in master and slave images)	Root	String	n.m							a								
Processing	CRG Warp degree	Degree of warp in Coregistration (both in master and slave images)	Root	Double								a								
Processing	DEM Software Version	Version of the DEM generation software	Root	String	n.m									a						
Processing	ECEF Beam Centre Direction for Processing	Unitary vector corresponding to the direction of the beam central plane in Earth Centred - Earth Fixed reference frame. It models the average behavior of the antenna beam central plane within each subswath acquired, hence in the case of Spotlight mode, the jumping steering scheme adopted at the scene acquisition time, is ignored.	Root	Double(N6, 3)		a	x	x	x	x	x	x				x	x	x		
Processing	ECEF Beam Pointing for Processing	Unitary vector corresponding to the pointing of the antenna main lobe in Earth Centred - Earth Fixed reference frame. It models the average behavior of the antenna pointing within each subswath acquired. In the case of ScanSAR mode, a different model per each subswath is used.	S<mm>	Double(N6, 3)		a	x	x	x	x	x	x				x	x	x		
Processing	Equivalent Number of Looks	Theoretical value of the equivalent number of looks	SBI MBI	Double			a	m	x	x	m	x				x				



COSMO-SkyMed Mission and Products Description

Doc. N°. : ASI-CSM-PMG-NT-001
 Date : 31 May 2016
 Rev. : Issue 2
 Pag. : 121 of 151

PROGRAMMA COSMO-SkyMed

Area	Attribute name	Description	HDF5 Struct.	Data Type	Unit / ASCII repr.	RAW	SCS	DGM DSM	GEC	GTC	SPF	CRG	IPH COH	DEM	MOS	PBR	RGC	AZP	DOP	QLK	
Processing	Focusing Algorithm ID	Identifier of the processing algorithm adopted	Root	String			a	x	x	x	x	x				x					
Processing	Incidence Angle Rescaling Factor	Scaling factor used for representation of Incidence Angle in the GIM layer	GIM	Double						a											

Value used to fill invalid pixels/lines.
 Are catalogued as invalid, the following categories of data:
 - compensated mi 21.e.55 22..58 321.55 0.4€

Processing Invalid Value



COSMO-SkyMed Mission and Products Description

Doc. N°. : ASI-CSM-PMG-NT-001
 Date : 31 May 2016
 Rev. : Issue 2
 Pag. : 122 of 151

PROGRAMMA COSMO-SkyMed

Area	Attribute name	Description	HDF5 Struc.	Data Type	Unit / ASCII repr.	RAW	SCS	DGM DSM	GEC	GTC	SPF	CRG	IPH COH	DEM	MOS	PBR	RGC	AZP	DOP	QLK	
Processing	ITF Common Band Range Filter Flag	Flag indicating if the range filter has been applied	Root	UByte									a								
Processing	ITF Demodulation Phase Reference Surface	Designator of the surface used for the evaluation of the demodulation phase	Root	String									a								
Processing	ITF Layover Filter Flag	Flag indicating if the layover filter has been applied	Root	UByte									a								
Processing	ITF Software Version	Version of the interferometric software	Root	String	n.m								a								
Processing	L0 Software Version	Version of the L0 processor used for the core processing step	Root	String	n.m	a	x	x	x	x	x	x				x	x	x			
	L1A	Version of the L1A processor used for the processing step	Root	String	n.m		a	x	x	x	x	x				x					
		Version of the L1B processor used for the processing step	Root	String	n.m			a	x	x	x	x									
		Version of the L1C processor used for the processing step	Root	String	n.m				a												



COSMO-SkyMed Mission and Products Description

Doc. N°. : ASI-CSM-PMG-NT-001

Date : 31 May 2016

Rev. : Issue 2

Pag. : 123 of 151

PROGRAMMA COSMO-SkyMed

Area	Attribute name	Description	HDF5 Struct.	Data Type	Unit / ASCII repr.	RAW	SCS	DGM DSM	GEC	GTC	SPF	CRG	IPH COH	DEM	MOS	PBR	RGC	AZP	DOP	QLK
Processing	Line Spacing	Spacing among lines of the products. It is expressed in degrees in the case of GEODETIC projection, in meters otherwise.	SBI MBI	Double	m deg		a	m	m	m	x	m	m	m	m	m				
Processing	Line Time Interval	Time spacing in the azimuth direction between lines	SBI MBI	Double	s		a	m			x	m	m			m				
Processing	Master Reference UTC	UTC with respect the annotated slow times of the Master image are referred to. It is set to the 00:00:00.000000000 of the day at which the acquisition started.	Root	String	Epoch								a	x						
Processing	MOS Master Tile	Identifier of the tile used as master in the mosaicking process	Root	String											a					
Processing	MOS Software Version	Version of the mosaicking software	Root	String	n.m										a					
Processing	Multilook filter flag	Flag indicating if the multilook filter has been applied	Root	UByte			a	m	x	x	x	x	m			x				
Processing	Processing History Bit Mask	Bit Mask used to identify the processing steps, the SAR data has been submitted to. The coding rule is given in the next table.	Root	ULong		a	m	m	m	m	m	m	m	m	m	m	m	m	m	
Processing	Product Error Flag	Flag indicating if errors have been reported during the product generation process. If set, it means that some quality measure is not compliant to the product specification. User should then refer to the product confidence data for details about the error condition.	Root	UByte		a	a	a	a	a	a	a	a	a	a	a	a	a	a	
Processing	Product Generation UTC	Product generation time in UTC time format	Root	String	Epoch	a	a	a	a	a	a	a	a	a	a	a	a	a	a	



COSMO-SkyMed Mission and Products Description

Doc. N°. : ASI-CSM-PMG-NT-001
 Date : 31 May 2016
 Rev. : Issue 2
 Pag. : 124 of 151

PROGRAMMA COSMO-SkyMed

Area	Attribute name	Description	HDF5 Struc.	Data Type	Unit / ASCII repr.	RAW	SCS	DGM DSM	GEC	GTC	SPF	CRG	IPH COH	DEM	MOS	PBR	RGC	AZP	DOP	QLK	
Processing	Quick Look Column Spacing	Spacing among columns of the quick look layer. It is expressed in degrees in the case of GEODETIC projection, in meters otherwise.	QLK	Double	m	a	a	a	a	a	a	a	a	a	a	a					x
Processing	Quick Look Line Spacing	Spacing among columns of the quick look layer. It is expressed in degrees in the case of GEODETIC projection, in meters otherwise.	QLK	Double	m	a	a	a	a	a	a	a	a	a	a	a					x
Processing	Range Bandwidth per Look	Bandwidth per look in range used for the multilooked image formation	S<mm>	Double	Hz			a	x	x	x	x									
Processing	Range Focusing Bandwidth	The bandwidth in range used at the single-look generation time	S<mm>	Double	Hz		a	x	x	x	x	x				x	a	a			
Processing	Range Focusing Transition Bandwidth	The transition bandwidth in range used at the single-look generation time	S<mm>	Double	Hz		a	x	x	x	x	x				x	a	a			
Processing	Range Focusing Weighting Coefficient	Range coefficients used for the weighting function applied at the focusing time to the processed portion of the full band	Root	Double			a	x	x	x	x	x				x	a	a			
Processing	Range Focusing Weighting Function	Type of matched filter windowing in the range direction at the focusing time	Root	String			a	x	x	x	x	x				x	a	a			
Processing	Range Multilooking Transition Bandwidth	The transition bandwidth in range used at the multilooked image formation	S<mm>	Double	Hz			a	x	x	x	x									



COSMO-SkyMed Mission and Products Description

Doc. N°. : ASI-CSM-PMG-NT-001
 Date : 31 May 2016
 Rev. : Issue 2
 Pag. : 125 of 151

PROGRAMMA COSMO-SkyMed

Area	Attribute name	Description	HDF5 Struc.	Data Type	Unit / ASCII repr.	RAW	SCS	DGM DSM	GEC	GTC	SPF	CRG	IPH COH	DEM	MOS	PBR	RGC	AZP	DOP	QLK	
Processing	Range Multilooking Weighting Coefficient	Range coefficients used for the weighting function applied at the multilooking time to each look	Root	Double				a	x	x	x	x									
Processing	Range Multilooking Weighting Function	Type of matched filter windowing in the range direction at the multilooking time	Root	String				a	x	x	x	x									
Processing	Range Processing Number of Looks	Number of nominal looks in the range direction	Root	UByte			a	m	x	x	m	x	m			x					
Processing	RAW Statistics Block Size	Size (in number of rows and number of columns) of the block where statistics on the RAW data are evaluated. In the following, N9 (resp. N10) will indicate the number of azimuth (resp. range) blocks (derived from the block size for statistics evaluation) in the burst over which statistics are evaluated. It is always assumed that: - first block for statistics evaluation is anchored to the first row/col of the burst - moving steps for other block determination is equal to the block size - block size is defined so that N9 <= 300 and N10 <= 3	S<mm>	UInt(2)		a	x	x	x	x	x	x				x	x	x			



COSMO-SkyMed Mission and Products Description

Doc. N°. : ASI-CSM-PMG-NT-001
 Date : 31 May 2016
 Rev. : Issue 2
 Pag. : 126 of 151

PROGRAMMA COSMO-SkyMed

Area	Attribute name	Description	HDF5 Struc.	Data Type	Unit / ASCII repr.	RAW	SCS	DGM DSM	GEC	GTC	SPF	CRG	IPH COH	DEM	MOS	PBR	RGC	AZP	DOP	QLK
Processing	Reference UTC	UTC with respect the annotated slow times are referred to. It is set to the 00:00:00.000000000 of the day at which the acquisition started. For mosaicked products it is annexed only to tiles.	Root T<jjj>	String	Epoch	a	x	x	x	x	x	x			x	x	x	x	x	
Processing	Replica Reconstruction Method	Designator of method for reconstruction of chirp used for image processing. Set to invalid value in the Spotlight case.	Root	String			a	x	x	x	x					x				
Processing	Rescaling Factor	Rescaling Factor F, used at processing time as a multiplier term applied to the signal amplitude to appropriately use the dynamic range allowed by the data type (avoiding the image saturation and minimizing quantization error).	Root	Double			a	m	m	m	m	x				m	a	a		
Processing	Slave Reference UTC	UTC with respect the annotated slow times of the Slave image are referred to. It is set to the 00:00:00.000000000 of the day at which the acquisition started.	Root	String	Epoch								a	x						
Processing	SPF Azimuth Moving Window	Speckle Filter Moving Window Length in Azimuth direction Set to 0 in the case speckle filtering is not applied.	Root	UShort				a	x	x	a									
Processing	SPF Filter Type	Applied Speckle Filter	Root	String				a	x	x	a									
Processing	SPF Iteration	Number of iterations of the applied Speckle Filter Set to 0 in the case speckle filtering is not applied.	Root	UShort				a	x	x	a									



**COSMO-SkyMed Mission
and Products Description**

Doc. N°. : ASI-CSM-PMG-NT-001
 Date : 31 May 2016
 Rev. : Issue 2
 Pag. : 127 of 151

PROGRAMMA COSMO-SkyMed

	Attribute		HDF5 Struc.	Data Type	Unit / ASCII repr.	RAW	SCS	DGM DSM	GEC	GTC	SPF	CRG	IPH COH	DEM	MOS	PBR	RGC	AZP	DOP	QLK
Processing	SPF Range Moving	Speckle Filter Moving Window Length in Range direction In the case speckle filtering is not	Root	UShort				a	x	x	a									
Processing	SPF Software Version	Version of the Speckle Filtering processor. Set to "0.0" in the case speckle filtering is not applied.	Root	String	n.m			a	x	x	a									
Processing	Subswath Change Column	Column index at which the subswath changes (used only for L1B ScanSAR products, set to invalid value otherwise). Its dimension, is equal to the number of subswath minus one in ScanSAR mode, and to one if unused.	SBI MBI	UInt(N3)				a												
Processing	Unwrapping Flag	Flag indicating if the unwrapping has been applied (interferometric DEM)	Root	UByte										a						



COSMO-SkyMed Mission and Products Description

Doc. N°. : ASI-CSM-PMG-NT-001
 Date : 31 May 2016
 Rev. : Issue 2
 Pag. : 128 of 151

PROGRAMMA COSMO-SkyMed

Area	Attribute name	Description	HDF5 Struc.	Data Type	Unit / ASCII repr.	RAW	SCS	DGM DSM	GEC	GTC	SPF	CRG	IPH COH	DEM	MOS	PBR	RGC	AZP	DOP	QLK	
Projection	Ground Projection Polynomial Reference Range	Reference slant range used as zero to represent the ground to slant (and viceversa) polynomials. Set to invalid value in the case of products not represented in ground range/azimuth projection	Root	Double	m			a			x	x			m						
Projection	Ground Projection Reference Surface	Designator of the surface used for the ground projection	Root	String				a	a	a	x	x			x						
Projection	Ground to Slant Polynomial	Ground range (pixels) to relative (w.r.t. the Ground Projection Polynomial Reference Range) slant range (meters) polynomial coefficient (from lower to higher degree). Set to invalid value in the case of products not represented in ground range/azimuth projection	Root	Double(6)	m/pix ⁱ			a			x	x			m						
Projection	Map Projection Centre	Geodetic coordinates (lat/lon) of the map projection centre (for UTM/UPS) In the case of UTM projection, latitude is set to 0 and longitude is set equal to that one of the central meridian of the UTM zone of the product. In the case of UPS projection, a projection centre equal to [90, 0] is used in the Northern emisphere, [-90, 0] is used in the Southern one Set to [0, 0] in the case of GEODETIC projection	Root	Double(2)					a	a				x	x						



COSMO-SkyMed Mission and Products Description

Doc. N°. : ASI-CSM-PMG-NT-001
 Date : 31 May 2016
 Rev. : Issue 2
 Pag. : 129 of 151

PROGRAMMA COSMO-SkyMed

Area	Attribute name	Description	HDF5 Struc.	Data Type	Unit / ASCII repr.	RAW	SCS	DGM DSM	GEC	GTC	SPF	CRG	IPH COH	DEM	MOS	PBR	RGC	AZP	DOP	QLK
Projection	Map Projection False East-North	Map Projection False East/North (for UTM/UPS) In the case of UTM projection, false east equal to 500000 is used, while false north equal to 0 in the Northern emisphere and 10000000 in the Southern one are used. In the case of UPS zone, a value of 2000000 is used both for false east and false north Set to QNaN otherwise	Root	Double(2)	m				a	a				a	x					
Projection	Map Projection Scale Factor	Map Projection Scale factor (for UTM/UPS). In the case of UTM projection, a value of 0.9996 is used. In the case of UPS projection, a value of 0.994 is used. Set to QNaN otherwise	Root	Double					a	a				a	x					
Projection	Map Projection Zone	Map Projection Zone	Root	UByte					a	a				a	x					
Projection	Projection ID	Projection descriptor For geocoded product UPS projection is used if the scene centre latitude is greater than 84° or lower than -80°, otherwise UTM is used	Root	String		a	m	m	m	m	x	x	m	m	x	x	m	m	m	
Projection	Quick Look Projection ID	Projection descriptor for Quick Look Layer For geocoded product UPS projection is used if the scene centre latitude is greater than 84° or lower than -80°, otherwise UTM is used	QLK	String		a	a	a	a	a	a	a	a	a	a	a				x



COSMO-SkyMed Mission and Products Description

Doc. N°. : ASI-CSM-PMG-NT-001
 Date : 31 May 2016
 Rev. : Issue 2
 Pag. : 130 of 151

PROGRAMMA COSMO-SkyMed

Area	Attribute name	Description	HDF5 Struc.	Data Type	Unit / ASCII repr.	RAW	SCS	DGM DSM	GEC	GTC	SPF	CRG	IPH COH	DEM	MOS	PBR	RGC	AZP	DOP	QLK	
Projection	Slant to Ground Polynomial	Relative (w.r.t. the Ground Projection Polynomial Reference Range) slant range (meters) to ground range (pixels) polynomial coefficients (from the lower to the higher degree). Set to invalid value in the case of products not represented in ground range/azimuth projection	Root	Double(6)	pix/m ⁱ			a			x	m			m						
Scene	Azimuth Coverage	Coverage in the azimuth direction of the full scene estimated on the ellipsoid. Attribute updating is applicable in the case of processing of image portion starting from Level 0 data.	Root	Double	m	a	m	m	x	x	x	m	x	x		x	m	m			
Scene	Bottom Left East-North	Coordinates of the first pixel of the last image line for metric projections. Set to QNaN otherwise. In the case of mosaicked products it is annexed both to the mosaic and to the tile	SBI MBI T<jjj>	Double(2)	m				a	a				a	m						
Scene	Bottom Left Geodetic Coordinates	Geodetic coordinates (Lat-Lon-Ellipsoidal Height) of the first pixel of the last image line (estimated on DEM for terrain projected products, on the ellipsoid otherwise) Attribute updating is also applicable in the case of processing of image portion starting from Level 0 data. In the case of mosaicked products it is annexed both to the mosaic and to the tile	SBI MBI T<jjj>	Double(3)	(deg, deg, m)		a	m	m	m	x	m	x	m	m	x					
Scene	Bottom Right East-North	Coordinates of the last pixel of the last image line for metric projections. Set to QNaN otherwise. In the case of mosaicked products it is annexed both to the mosaic and to the tile	SBI MBI T<jjj>	Double(2)	m				a	a				a	m						



COSMO-SkyMed Mission and Products Description

Doc. N°. : ASI-CSM-PMG-NT-001
 Date : 31 May 2016
 Rev. : Issue 2
 Pag. : 131 of 151

PROGRAMMA COSMO-SkyMed

Area	Attribute name	Description	HDF5 Struc.	Data Type	Unit / ASCII repr.	RAW	SCS	DGM DSM	GEC	GTC	SPF	CRG	IPH COH	DEM	MOS	PBR	RGC	AZP	DOP	QLK
Scene	Bottom Right Geodetic Coordinates	Geodetic coordinates (Lat-Lon-Ellipsoidal Height) of the last pixel of the last image line (estimated on DEM for terrain projected products, on the ellipsoid otherwise). Attribute updating is also applicable in the case of processing of image portion starting from Level 0 data. In the case of mosaicked products it is annexed both to the mosaic and to the tile	SBI MBI T<jjj>	Double(3)	(deg, deg, m)		a	m	m	m	x	m	x	m	m	x				
Scene	Centre Earth Radius	Earth radius at image centre. Attribute updating is applicable in the case of processing of image portion starting from Level 0 data.	Root	Double	m	a	m	m	x	x	x	x	x	x	m	x	m	m		
Scene	Centre Geodetic Coordinates	Geodetic coordinates (lat-lon-height) of the central image point (estimated on DEM for terrain projected products, on the ellipsoid otherwise) of the swath. For RAW data it is estimated in acquisition geometry on the basis of the acquisition time of the central line discarding transients to be removed by range compression. Attribute updating is also applicable in the case of processing of image portion starting from Level 0 data.	S<mm>	Double(3)	(deg, deg, m)	a	m	m	m	m	x	m	x	x		x	m	m		



COSMO-SkyMed Mission and Products Description

Doc. N°. : ASI-CSM-PMG-NT-001
 Date : 31 May 2016
 Rev. : Issue 2
 Pag. : 132 of 151

PROGRAMMA COSMO-SkyMed

Area	Attribute name	Description	HDF5 Struc.	Data Type	Unit / ASCII repr.	RAW	SCS	DGM DSM	GEC	GTC	SPF	CRG	IPH COH	DEM	MOS	PBR	RGC	AZP	DOP	QLK	
Scene	DeltaSideWardLooking Angle	Nominal look angle of the full observed swath (unsigned angle between nominal reference direction of the multi-beam and satellite nadir) expressed in millidegree	Root	Uint9digit																	x
Scene	Estimated Bottom Left Geodetic Coordinates	Estimated geodetic coordinates (Lat-Lon-0) of the first pixel/last line of the correspondent focussed image	Root	Double(3)	(deg, deg, m)	a															
Scene	Estimated Bottom Right Geodetic Coordinates	Estimated geodetic coordinates (Lat-Lon-0) of the last pixel/last line of the correspondent focussed image	Root	Double(3)	(deg, deg, m)	a															
Scene	Estimated Top Left Geodetic Coordinates	Estimated geodetic coordinates (Lat-Lon-0) of the first pixel/first line of the correspondent focussed image	Root	Double(3)	(deg, deg, m)	a															
Scene	Estimated Top Right Geodetic Coordinates	Estimated geodetic coordinates (Lat-Lon-0) of the last pixel/first line of the correspondent focussed image	Root	Double(3)	(deg, deg, m)	a															



COSMO-SkyMed Mission and Products Description

Doc. N°. : ASI-CSM-PMG-NT-001
 Date : 31 May 2016
 Rev. : Issue 2
 Pag. : 133 of 151

PROGRAMMA COSMO-SkyMed

Area	Attribute name	Description	HDF5 Struc.	Data Type	Unit / ASCII repr.	RAW	SCS	DGM DSM	GEC	GTC	SPF	CRG	IPH COH	DEM	MOS	PBR	RGC	AZP	DOP	QLK	
Scene	Far Early Geodetic Coordinates	Geodetic coordinates of the pixel of the scene acquired at the far range at the azimuth first time (estimated on DEM for terrain projected products, on the ellipsoid otherwise) It is useful for geocoded products that are not represented in range azimuth projection, hence the image geometry doesn't correspond to the acquisition geometry	SBI MBI	Double(3)	(deg, deg, m)				a	a				a							
Scene	Far Incidence Angle	Absolute value of the incidence angle measured at the far range on the ellipsoid in zero-doppler geometry as derived by the sampling window times represented in data	SBI MBI	Double	deg		a	x	x	x	x	x				x					
Scene	Far Late Geodetic Coordinates	Geodetic coordinates of the pixel of the scene acquired at the far range at the azimuth last time (estimated on DEM for terrain projected products, on the ellipsoid otherwise) It is useful for geocoded products that are not represented in range azimuth projection, hence the image geometry doesn't correspond to the acquisition geometry	SBI MBI	Double(3)	(deg, deg, m)				a	a				a							
Scene	Far Look Angle	Look angle measured at the far range on the ellipsoid in zero-doppler geometry as derived by the sampling window times represented in data	SBI MBI	Double	deg		a	x	x	x	x	x				x					



COSMO-SkyMed Mission and Products Description

Doc. N°. : ASI-CSM-PMG-NT-001
 Date : 31 May 2016
 Rev. : Issue 2
 Pag. : 134 of 151

PROGRAMMA COSMO-SkyMed

Area	Attribute name	Description	HDF5 Struc.	Data Type	Unit / ASCII repr.	RAW	SCS	DGM DSM	GEC	GTC	SPF	CRG	IPH COH	DEM	MOS	PBR	RGC	AZP	DOP	QLK	
Scene	FarRangeIncidenceAngle	Far incidence angle expressed in millidegree	Root	UInt9digit																	x
Scene	Ground Range Coverage	Coverage in ground range of the specific portion of data projected on the ellipsoid. For RAW data it is computed on the basis of the acquisition times and geometry, with right transient removed (i.e. only considering scatterers which returns a complete chirp's echo to the SAR receiver). Attribute updating is applicable in the case of processing of image portion starting from Level 0 data.	Root	Double	m	a	m	m	x	x	x	m	x	x		x	m	m			
Scene	Master Scene Look Angle	Angle between the centre of the full scene as it is derived from the sampling window times (estimated on the reference ellipsoid in zero-doppler geometry) and the geodetic nadir	Root	Double	deg								a	x							
Scene	Near Early Geodetic Coordinates	Geodetic coordinates of the pixel of the scene acquired at the near range at the azimuth first time (estimated on DEM for terrain projected products, on the ellipsoid otherwise) It is useful for geocoded products that are not represented in range azimuth projection, hence the image geometry doesn't correspond to the acquisition geometry	SBI MBI	Double(3)	(deg, deg, m)				a	a				a							
Scene	Near Incidence Angle	Absolute value of the incidence angle measured at the near range on the ellipsoid in zero-doppler geometry as derived by the sampling window times represented in data	SBI MBI	Double	deg		a	x	x	x	x	x				x					



COSMO-SkyMed Mission and Products Description

Doc. N°. : ASI-CSM-PMG-NT-001
 Date : 31 May 2016
 Rev. : Issue 2
 Pag. : 135 of 151

PROGRAMMA COSMO-SkyMed

Area	Attribute name	Description	HDF5 Struc.	Data Type	Unit / ASCII repr.	RAW	SCS	DGM DSM	GEC	GTC	SPF	CRG	IPH COH	DEM	MOS	PBR	RGC	AZP	DOP	QLK	
Scene	Near Late Geodetic Coordinates	Geodetic coordinates of the pixel of the scene acquired at the near range at the azimuth last time (estimated on DEM for terrain projected products, on the ellipsoid otherwise) It is useful for geocoded products that are not represented in range azimuth projection, hence the image geometry doesn't correspond to the acquisition geometry	SBI MBI	Double(3)	(deg, deg, m)				a	a				a							
Scene	Near Look Angle	Look angle measured at the near range on the ellipsoid in zero-doppler geometry as derived by the sampling window times represented in data	SBI MBI	Double	deg		a	x	x	x	x	x				x					





COSMO-SkyMed Mission and Products Description

Doc. N°. : ASI-CSM-PMG-NT-001
 Date : 31 May 2016
 Rev. : Issue 2
 Pag. : 136 of 151

PROGRAMMA COSMO-SkyMed

Area	Attribute name	Description	HDF5 Struc.	Data Type	Unit / ASCII repr.	RAW	SCS	DGM DSM	GEC	GTC	SPF	CRG	IPH COH	DEM	MOS	PBR	RGC	AZP	DOP	QLK	
Scene	NearRange IncidenceAngle	Near incidence angle expressed in millidegree	Root	UInt 9digit																	x
Scene	Polygon	<p>List of vertex of the polygonal shape in term of Longitude and Latitude coordinates according to the following string <u>format</u>:</p> <p>[Point_1;Point_2;..... ;Point_x]</p> <p>where « <i>Point_x</i> » is defined as a couple Longitude:Latitude in the string <u>format</u>:</p> <p>FLOAT(010,5):FLOAT(010,6)</p> <p>with ranges, LONGITUDE: [-179.99999, 180.00000] ; LATITUDE: [-90.000000, 90.000000] .</p> <p>Vertex must be specified in a counter-clockwise direction.</p> <p>Closing point must not be included in the vertexes list</p> <p>Example: [-034.46557;067.684536;0156.37529;-63.760346;0156.16023;-63.741403;-034.21402;067.668000]</p>	Root	String																	x

 	COSMO-SkyMed Mission and Products Description	Doc. N°. : ASI-CSM-PMG-NT-001 Date : 31 May 2016 Rev. : Issue 2 Pag. : 137 of 151
PROGRAMMA COSMO-SkyMed		

Area	Attribute name	Description	HDF5 Struc.	Data Type	Unit / ASCII repr.	RAW	SCS
------	----------------	-------------	-------------	-----------	--------------------	-----	-----



COSMO-SkyMed Mission and Products Description

Doc. N°. : ASI-CSM-PMG-NT-001
 Date : 31 May 2016
 Rev. : Issue 2
 Pag. : 138 of 151

PROGRAMMA COSMO-SkyMed

Area	Attribute name	Description	HDF5 Struc.	Data Type	Unit / ASCII repr.	RAW	SCS	DGM DSM	GEC	GTC	SPF	CRG	IPH COH	DEM	MOS	PBR	RGC	AZP	DOP	QLK
Scene	Terrain Elevation Standard Deviation	Standard deviation of the elevation of the observed scene	Root	Double	m					a										
Scene	Terrain Maximum Elevation	Maximum elevation of the observed scene	Root	Double	m					a										
Scene	Terrain Mean Elevation	Mean elevation of the observed scene	Root	Double	m					a										
Scene	Terrain Minimum Elevation	Minimum elevation of the observed scene	Root	Double	m					a										
Scene	Top Left East-North	Coordinates of the first pixel of the first image line for metric projections. Set to QNaN otherwise. In the case of mosaicked products it is annexed both to the mosaic and to the tile Geodetic coordinates (Lat-Lon-Ellipsoidal	SBI MBI T<jjj>	Double(2)	m				a	a				a	m					

Scene Top Left Geodetic Coordinates



COSMO-SkyMed Mission and Products Description

Doc. N°. : ASI-CSM-PMG-NT-001
 Date : 31 May 2016
 Rev. : Issue 2
 Pag. : 139 of 151

PROGRAMMA COSMO-SkyMed

Area	Attribute name	Description	HDF5 Struc.	Data Type	Unit / ASCII repr.	RAW	SCS	DGM DSM	GEC	GTC	SPF	CRG	IPH COH	DEM	MOS	PBR	RGC	AZP	DOP	QLK
Scene	Top Right Geodetic Coordinates	Geodetic coordinates (Lat-Lon-Ellipsoidal Height) of the last pixel of the first image line (estimated on DEM for terrain projected products, on the ellipsoid otherwise) Attribute updating is also applicable in the case of processing of image portion starting from Level 0 data. In the case of mosaicked products it is annexed both to the mosaic and to the tile	SBI MBI T<jjj>	Double(3)	(deg, deg, m)		a	m	m	m	x	m	x	m	m	x				



COSMO-SkyMed Mission and Products Description

Doc. N°. : ASI-CSM-PMG-NT-001
 Date : 31 May 2016
 Rev. : Issue 2
 Pag. : 140 of 151

PROGRAMMA COSMO-SkyMed

Area	Attribute name	Description	HDF5 Struc.	Data Type	Unit / ASCII repr.	RAW	SCS	DGM DSM	GEC	GTC	SPF	CRG	IPH COH	DEM	MOS	PBR	RGC	AZP	DOP	QLK	
Sensor	SensingMethodActivePassiveType	Short Code for the active/passive type. <u>Allowed values:</u> A active sensor P passive sensor <u>Set values:</u> A active sensor	Root	String 1char																	x
Sensor	SensingMethodSensingType	Short Code for the sensing type. <u>Allowed values:</u> S earth surface sensing A atmospheric sounder L limb sounder atmospheric sensing V vertical altitude sensing <u>Set values:</u> S earth surface sensing	Root	String 1char																	x



COSMO-SkyMed Mission and Products Description

Doc. N°. : ASI-CSM-PMG-NT-001
 Date : 31 May 2016
 Rev. : Issue 2
 Pag. : 141 of 151

PROGRAMMA COSMO-SkyMed

Area	Attribute name	Description	HDF5 Struc.	Data Type	Unit / ASCII repr.	RAW	SCS	DGM DSM	GEC	GTC	SPF	CRG	IPH COH	DEM	MOS	PBR	RGC	AZP	DOP	QLK	
Sensor	SensingMethodSpectrumType	<p>Short Code for the spectrum type. <u>Allowed values:</u> h HF ($\lambda > 10m$, $\nu < 50MHz$) v VHF ($\lambda > 1m$, $\nu < 300MHz$) m microwave ($\lambda = 1cm..100cm$, $\nu \sim 0.3GHz$ to $30GHz$) M millimetrevawe ($\lambda = 1mm..1cm$, ν in $100GHz$ range) S sub-millimetrevawe ($\lambda = 0.1mm..1mm$, $\nu < THZ$ range) I infra-red ($\lambda \sim 0.8\mu m..0.1mm$, $\nu > THZ$ range) V visible ($\lambda \sim 0.39\mu m..0.8\mu m$, $\nu < PetaHZ$ range) U ultra-violet ($\lambda < 0.39\mu m$, ν in $PetaHZ$ range)</p> <p><u>Set values:</u> m microwave ($\lambda = 1cm..100cm$, $\nu \sim 0.3GHz$ to $30GHz$)</p>	Root	String 1char																	x
Specification	Azimuth Geometric Resolution	<p>Performance guaranteed for Azimuth geometric resolution (including weighting and multilooking effects) in order to be compliant with the product specifications. Set to NaN for mosaicked DEM.</p>	Root	Double	m		a	a	a	a	m	x			m	m					



COSMO-SkyMed Mission and Products Description

Doc. N°. : ASI-CSM-PMG-NT-001
 Date : 31 May 2016
 Rev. : Issue 2
 Pag. : 142 of 151

PROGRAMMA COSMO-SkyMed

Area	Attribute name	Description	HDF5 Struc.	Data Type	Unit / ASCII repr.	RAW	SCS	DGM DSM	GEC	GTC	SPF	CRG	IPH COH	DEM	MOS	PBR	RGC	AZP	DOP	QLK	
Specificatio n	DEM Absolute Horizontal Accuracy	Accuracy of the horizontal position of the DEM points caused by random and uncorrected systematic errors, expressed as the maximum absolute difference between the true and measured values with a 90% confidence level, i.e. excluding the 10% worst points. Set to invalid value if product is not a DEM	Root	Double	m									a	m						
Specificatio n	DEM Absolute Vertical Accuracy	Accuracy of the height of the DEM points caused by random and uncorrected systematic errors, expressed as the maximum absolute difference between the true and measured values with a 90% confidence level, i.e. excluding the 10% worst points. Set to invalid value if product is not a DEM	Root	Double	m									a	m						
Specificatio n	DEM Relative Horizontal Accuracy	Accuracy of the horizontal relative position of each two points in a small area of the DEM caused by random errors, expressed as the maximum absolute value of the unbiased difference between the true and measured values with a 90% confidence level, i.e. excluding the 10% worst points. Set to invalid value if product is not a DEM	Root	Double	m									a	m						
Specificatio n	DEM Relative Vertical Accuracy	Accuracy of the relative height of each two points in a small area of the DEM caused by random errors, expressed as the maximum absolute value of the unbiased difference between the true and measured values with a 90% confidence level, i.e. excluding the 10% worst points. Set to invalid value if product is not a DEM	Root	Double	m									a	m						



COSMO-SkyMed Mission and Products Description

Doc. N°. : ASI-CSM-PMG-NT-001
 Date : 31 May 2016
 Rev. : Issue 2
 Pag. : 143 of 151

PROGRAMMA COSMO-SkyMed

Area	Attribute name	Description	HDF5 Struc.	Data Type	Unit / ASCII repr.	RAW	SCS	DGM DSM	GEC	GTC	SPF	CRG	IPH COH	DEM	MOS	PBR	RGC	AZP	DOP	QLK
Specificatio n	Geolocation Accuracy	Performance guaranteed for Geolocation (30 Accuracy in order to be compliant with the product specifications)	Root	Double	m			a	a	a	x									
Specificatio n	Geometric Conformity	Performance guaranteed for Geometric Conformity in order to be compliant with the product specifications	Root	Double				a	a	a	x									
Specificatio n	Ground Range Geometric Resolution	Performance guaranteed for Ground Range geometric resolution (including weighting and multilooking effects) in the worst case (that is at near range) in order to be compliant with the product specifications	Root	Double	m		a	a	a	a	m	x			m	m				
Specificatio n	Inter-channel Co-registration	Performance guaranteed for Co-registration between differently polarized channels of PingPong products, in order to be compliant with the product specifications. Set to QNaN for other instrument modes.	Root	Double	pix		a	a	a	a	x	m				x				
Specificatio n	IRF Shape -10dB/-3dB	Performance guaranteed for ratio of IRF Shape measured at -10 dB and -3dB in order to be compliant with the product specifications	Root	Double			a	a	a	a	x					m				
Specificatio n	IRF Shape -6dB/-3dB	Performance guaranteed for ratio of IRF Shape measured at -6 dB and -3dB in order to be compliant with the product specifications	Root	Double			a	a	a	a	x					m				
Specificatio n	ISLR	Performance (range/azimuth) guaranteed for ISLR in order to be compliant with the product specifications	Root	Double(2)	dB		a	a	a	a	x					a				
Specificatio n	Local Radiometric Stability	Performance guaranteed for Local Radiometric Stability in order to be compliant with the product specifications	Root	Double	dB		a	a	a	a	x					x				



COSMO-SkyMed Mission and Products Description

Doc. N°. : ASI-CSM-PMG-NT-001
 Date : 31 May 2016
 Rev. : Issue 2
 Pag. : 144 of 151

PROGRAMMA COSMO-SkyMed

Area	Attribute name	Description	HDF5 Struc.	Data Type	Unit / ASCII repr.	RAW	SCS	DGM DSM	GEC	GTC	SPF	CRG	IPH COH	DEM	MOS	PBR	RGC	AZP	DOP	QLK
Specificatio n	Phase Continuity	Performance (mean and standard deviation) guaranteed for Phase Continuity in order to be compliant with the product specifications	Root	Double(2)	deg		a									x				
Specificatio n	Point Target Ambiguity	Performance guaranteed for Point Target Ambiguity in order to be compliant with the product specifications	Root	Double	dB		a	a	a	a	x					x				
Specificatio n	PSLR	Performance (range/azimuth) guaranteed for PSLR in order to be compliant with the product specifications	Root	Double(2)	dB		a	a	a	a	x					a				
Specificatio n	Radiometric Accuracy	Performance guaranteed for Radiometric Accuracy in order to be compliant with the product specifications	Root	Double	dB					a										
Specificatio n	Radiometric Linearity	Performance guaranteed for Radiometric Linearity in order to be compliant with the product specifications	Root	Double	dB					a										
Specificatio n	Radiometric Stability	Performance guaranteed for Radiometric Stability in order to be compliant with the product specifications	Root	Double	dB					a										
Specificatio n	SSLR	Performance (range/azimuth) guaranteed for SSLR in order to be compliant with the product specifications	Root	Double(2)	dB		a	a	a	a	x					a				
Thresholds	CRG Overlapping Percentage Threshold	Threshold for AOI Overlapping (both in master and slave images) percentage w.r.t. the master image	Root	Double								a								
Thresholds	Doppler Ambiguity Confidence Measure Threshold	Normalized confidence measure of doppler centroid ambiguity. A value of zero means poor confidence.	Root	Double		a	x	x	x	x	x	x				x	x	x		



COSMO-SkyMed Mission and Products Description

Doc. N°. : ASI-CSM-PMG-NT-001
 Date : 31 May 2016
 Rev. : Issue 2
 Pag. : 145 of 151

PROGRAMMA COSMO-SkyMed

Area	Attribute name	Description	HDF5 Struc.	Data Type	Unit / ASCII repr.	RAW	SCS	DGM DSM	GEC	GTC	SPF	CRG	IPH COH	DEM	MOS	PBR	RGC	AZP	DOP	QLK
Thresholds	Doppler Ambiguity Threshold	Threshold for setting the Doppler Centroid ambiguity quality flag	Root	UShort		a	x	x	x	x	x					x	x	x		
Thresholds	Doppler Centroid Confidence Measure Threshold	Threshold for setting the Doppler Centroid confidence quality flag	Root	Double		a	x	x	x	x	x	x				x	x	x	x	
Thresholds	Doppler Centroid Estimation Accuracy Threshold	Threshold for setting the Doppler Centroid Accuracy quality flag	Root	Double	Hz	a	x	x	x	x	x	x				x	x	x	x	
Thresholds	Doppler Rate Confidence Measure Threshold	Threshold for setting the Doppler Rate confidence quality flag	Root	Double		a	x	x	x	x	x	x				x	x	x		
Thresholds	Doppler Rate Estimation Accuracy Threshold	Threshold for setting the Doppler Rate accuracy quality flag	Root	Double	Hz/s	a	x	x	x	x	x	x				x	x	x		
Thresholds	Image OverSaturated Percentage Threshold	Threshold for setting the OverSaturated Percentage quality flag	Root	Double			a	x	x	x	x	m				x				



COSMO-SkyMed Mission and Products Description

Doc. N°. : ASI-CSM-PMG-NT-001
 Date : 31 May 2016
 Rev. : Issue 2
 Pag. : 146 of 151

PROGRAMMA COSMO-SkyMed

Area	Attribute name	Description	HDF5 Struc.	Data Type	Unit / ASCII repr.	RAW	SCS	DGM DSM	GEC	GTC	SPF	CRG	IPH COH	DEM	MOS	PBR	RGC	AZP	DOP	QLK
Thresholds	Image UnderSaturated Percentage Threshold	Threshold for setting the UnderSaturated Percentage quality flag	Root	Double			a	x	x	x	x	m				x				
Thresholds	RAW Bias Threshold	Bias of RAW data used as threshold to set the product quality flag; two samples for the In-Phase and Quadrature signal (I-Q)	Root	Double		a	x	x	x	x	x	x				x	x	x		
Thresholds	RAW Gain Imbalance Threshold	Gain imbalance of the I and Q channel of the RAW data used as threshold to set the product quality flag. It is the maximum allowed absolute deviation of the measured value from the ideal unitary one.	Root	Double		a	x	x	x	x	x	x				x	x	x		
Thresholds	RAW I/Q Normality Threshold	Measure of the Gaussian properties of I and Q channels distribution used as threshold to set the product quality flag	Root	Double	deg	a	x	x	x	x	x	x				x	x	x		
Thresholds	RAW I/Q Orthogonality Threshold	Phase difference (orthogonality) between I and Q channels of RAW data used as threshold to set the product quality flag. It is the maximum allowed absolute deviation of the measured value from the ideal one equal to 90 degrees.	Root	Double	deg	a	x	x	x	x	x	x				x	x	x		
Thresholds	RAW Missing Lines per Block Threshold	Number of allowed missing lines which constitute a gap	Root	UShort		a	x	x	x	x	x	x				x	x	x		





COSMO-SkyMed Mission and Products Description

Doc. N°. : ASI-CSM-PMG-NT-001
 Date : 31 May 2016
 Rev. : Issue 2
 Pag. : 147 of 151



PROGRAMMA COSMO-SkyMed

Area	Attribute name	Description	HDF5 Struc.	Data Type	Unit / ASCII repr.	RAW	SCS	DGM DSM	GEC	GTC	SPF	CRG	IPH COH	DEM	MOS	PBR	RGC	AZP	DOP	QLK
Thresholds	RAW Missing Lines Percentage Threshold	Maximum percentage of missing lines to total lines.	Root	Double		a	x	x	x	x	x	x				x	x	x		
Thresholds	RAW OverSaturated Percentage Threshold	Percentage of RAW oversaturated pixels used as threshold to set the product quality flag	Root	Double		a	x	x	x	x	x	x				x	x	x		
Thresholds	RAW Phase Uniformity Threshold	Measure of the uniform properties of phase distribution of the RAW data used as threshold to set the product quality flag	Root	Double	deg	a	x	x	x	x	x	x				x	x	x		
Thresholds	RAW UnderSaturated Percentage Threshold	Percentage of RAW undersaturated pixels used as threshold to set the product quality flag	Root	Double		a	x	x	x	x	x	x				x	x	x		
Thresholds	Replica Geometric Resolution Threshold	Geometric resolution (meters in slant range) of the replica cross correlation function; it represents a threshold for setting the replica quality flag.	Root	Double	m	a														
Thresholds	Replica ISLR Threshold	ISLR of the chirp cross correlation function; it represents a threshold for setting the chirp quality flag.	Root	Double	dB	a														
Thresholds	Replica PSLR Threshold	PSLR of the chirp cross correlation function; it represents a threshold for setting the replica quality flag.	Root	Double	dB	a														

 agenzia spaziale italiana 	COSMO-SkyMed Mission and Products Description	Doc. N°. : ASI-CSM-PMG-NT-001 Date : 31 May 2016 Rev. : Issue 2 Pag. : 148 of 151
PROGRAMMA COSMO-SkyMed		

Area	Attribute name	Description	HDF5 Struc.	Data Type	Unit / ASCII repr.	RAW	SCS	DGM DSM	GEC	GTC	SPF	CRG	IPH COH	DEM	MOS	PBR	RGC	AZP	DOP	QLK	
Thresholds	Replica Shape - 10dB/-3dB Threshold	Aperture ratio of main lobe of reconstructed replica measured at -10 dB and -3dB; it represents a threshold for setting the replica quality flag.	Root	Double	dB	a															
Thresholds	Replica Shape - 6dB/-3dB Threshold	Aperture ratio of main lobe of reconstructed replica measured at -10 dB and -3dB; it represents a threshold for setting the replica quality flag.	Root	Double	dB	a															
Thresholds	Replica SSLR Threshold	SSLR of the chirp cross correlation function; it represents a threshold for setting the replica quality flag.	Root	Double	dB	a															



Table 29

 	COSMO-SkyMed Mission and Products Description	Doc. N°. : ASI-CSM-PMG-NT-001 Date : 31 May 2016 Rev. : Issue 2 Pag. : 149 of 151
PROGRAMMA COSMO-SkyMed		

10 Acronyms and Glossary

10.1 Acronyms

ASI	Italian Space Agency
ca.	around/about/in the order of
CPCM	Mission Control and Planning Center
C-UGS	Civilian User Ground Segment
DEM	Digital Elevation Model
DESS	Digital Electronics SubSystem
ENL	Equivalent Number of Looks
EO	Earth Observation
GEC	Geocoded Ellipsoid Corrected
GTC	Geocoded Terrain Corrected
HDF	Hierarchical Data Format
HK	House Keeping
HW	Hardware
IC-UGS	Italian Civilian User Ground Segment
I/F	Interface
NE	Noise Equivalent
PAW	Platform Activity Window
PRI	Precision Raw Image
SAR	Synthetic Aperture Radar
SCS	Single look, Complex, Slant Range products
SW	Software

 	COSMO-SkyMed Mission and Products Description	Doc. N°. : ASI-CSM-PMG-NT-001 Date : 31 May 2016 Rev. : Issue 2 Pag. : 150 of 151
PROGRAMMA COSMO-SkyMed		

10.2 Glossary

Acquisition Mode

One of the basic acquisition modes allowed by the SAR instrument

- Spotlight (Enhanced Spotlight)
- Stripmap (Himage, PingPong)
- ScanSAR (WideRegion, HugeRegion)

DEM

Digital Elevation Model. Terrain height data given on a regular map grid.

DGM Product

Synonymous with Level 1B Product

GEC Product

Synonymous with Level 1C Product

GTC Product

Synonymous with Level 1D Product

Incidence angle

It is the angle measured between the slant range direction and the normal to the tangent plane to the Earth surface in the specified point on ground

Level 0 data

L0 data (i.e. raw SAR telemetry) consists of time ordered echo data, obtained after decryption and before unpacking, and includes all UTC-dated auxiliary and ancillary data (e.g. orbit data, satellite's position and velocity, geometric sensor model, payload status, calibration data) required to produce the other basic and intermediate products.



Level 0 Data File

One Image Segment File (ISF) formatted as a sequence of Source Packets or VCDU's Data Zones (decrypted or not depending on decryption key availability).

The following standard processing levels are conceived for COSMO:

Level 0 Product

Level 0 product consists of time ordered echo data, obtained after decryption and decompression (i.e. conversion from BAQ encoded data to 8-bit uniformly quantised data) and after applying internal calibration and error compensation; this product shall include all the auxiliary data (e.g.: trajectography, accurately dated satellite's co-ordinates and speed vector, geometric sensor model, payload status, calibration data,..) required to produce the other basic and intermediate products.

 	COSMO-SkyMed Mission and Products Description	Doc. N°. : ASI-CSM-PMG-NT-001 Date : 31 May 2016 Rev. : Issue 2 Pag. : 151 of 151
PROGRAMMA COSMO-SkyMed		

Level 1A Product

Level 1A products (also indicated as Single-look Complex Slant (SCS)), consist of SAR focused data internally radiometric calibrated, in zero-doppler slant range-azimuth geometric projection, left at natural geometric spacing with associated ancillary data

Level 1B Product

Level 1B products (also indicated as Detected Ground Multi-look (MDG)), consist of SAR focused data internally radiometric calibrated, de-speckled, amplitude detected, projected in zero-doppler ground range-azimuth onto a reference ellipsoid or on a DEM, resampled at a regular spacing on ground with associated ancillary data.

Level 1C Product

Level 1C class of products (also indicated as Geocoded Ellipsoid Corrected (GEC)) is constituted by input data projected onto a reference ellipsoid chosen among a predefined set, in a regular grid obtained from a cartographic reference system chosen among a predefined set with associated ancillary data

Level 1D Products

Level 1D class of products (also indicated as Geocoded Terrain Corrected (GTC)) is constituted by input data projected onto a reference elevation surface in a regular grid obtained from a cartographic reference system chosen among a predefined set with associated ancillary data

Local incidence angle

The angle between the radar beam center and the normal to the local topography. The difference between the global incidence angle and the terrain slope.

Look angle

Of a SAR, the angle from the nadir at which the radar beam is pointed. Of a target, the angle between the SAR-nadir and SAR-target lines.

Raw Product

Synonymous of Level 0 Product

SAR Product

Generic term referring to the SAR data acquired in the different SAR modes and handled in the GS, at different level of processing (see also Level xxx Products).

The SAR products are catalogued in two classes:

- Standard products
- Non-standard products

SCS Product

Synonymous of Level 1A Product