

SEOSAR/PAZ SAR Mission: Panel Design and Performance



A. Zurita, A. Solana and the PAZ Team ⁽¹⁾

⁽¹⁾ all authors are with EADS CASA ESPACIO, Madrid, Spain



1. Introduction

SEOSAR/PAZ is the first Spanish high resolution X-Band Synthetic Aperture Radar. The entire system is being developed under control and supervision of Hisdesat, who is also responsible for satellite operation and data exploitation. EADS CASA Espacio is the Satellite prime contractor company leading a wide industrial consortium, while INTA is responsible for the Ground Segment.

System Parameters	
Lifetime	5.5 years
Orbit	514 km, polar dawn-dusk sunsynchronous
Revisit time	1 day
Imaging	420 s (max.), 3 min (average) per orbit
Modes	Stripmap, Scansar, Spotlight (single, dual, quad)
SAR antenna	12 active panels (0.7 x 4.8 m each)
Weight	1350 kg
Frequency	9.65 GHz (300 MHz bandwidth)
Downlink	300 Mbps X-Band (encrypted)

Table 1-1 System Parameters

2. Panel Design

Instrument panel consists of:

- 32 Antenna Subarrays (H&V)
- 32 Transmit-Receive Modules (TRM)
- 1 Panel Distribution Network (1:32)
- 1 Panel Calibration Network (1:32)
- 1 Panel Supply Unit
- 1 Panel Control Unit

Antenna Subarray



Figure 2-2 Subarray in anechoic chamber

TRM performs the following functions:

- Power amplification and phase adjustment the TX signal
- Amplification and phase adjustment of RX echo signals
- Switching between H and V
- Coupling RX and TX signals for calibration purposes

Panel Distribution/Calibration Networks

- Stripline Wilkinson dual power dividers 1:16 and 1:2 (double-stacked)
- Parallel feeding to minimize amplitude/phase errors

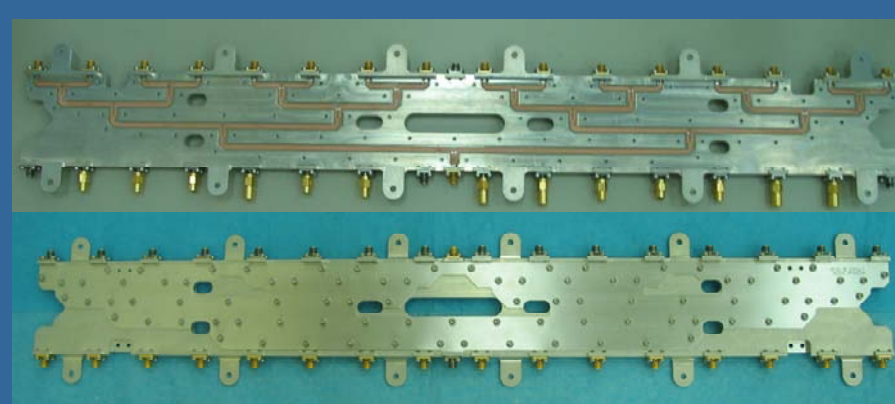

Figure 2-4 1:16 dual power divider

Panel Control Unit

- Control of panel 32 TRM (phase & amplitude) data take beam configurations
- TRM compensation: temperature, path offsets, biasing and parasitic effects

Panel Supply Unit

- Generation of 32 TRM secondary voltages

3. Panel Qualification

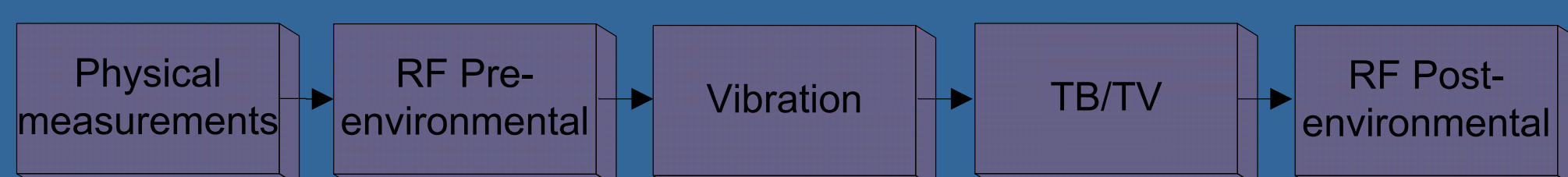

Figure 3-1 Qualification test campaign

- Physical measurements: mass, centre of gravity (z-axis)
- RF pre-environmental test: subarrays amplitude/phase offsets, antenna model first validation
- Vibration: sine and random vibration (3 axis)
- Thermal Balance/Thermal Vacuum: Qualification of thermal control system and evaluation of electrical and functional performances
- RF post-environmental: Embedded subarray beam patterns verification

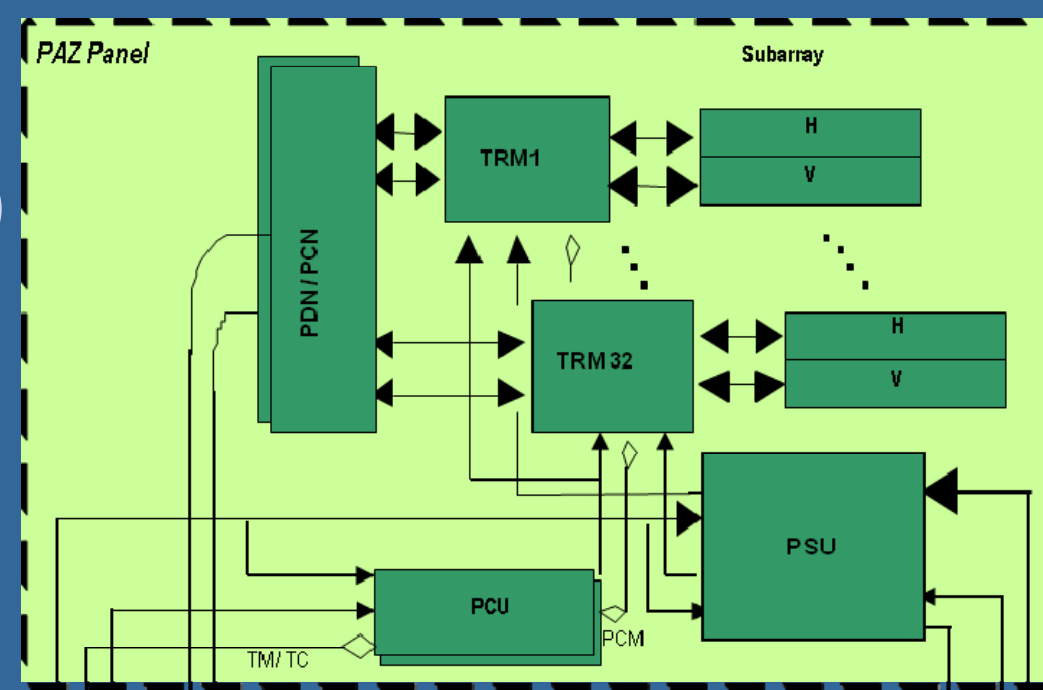

Figure 2-1 Panel functional architecture

Each subarray contains 16 circular patches spaced $0.7 \lambda \times 0.8 \lambda$ and fed via a multilayer stripline Beam Forming Network (H&V pol.). Measured losses achieved are $< 1\text{dB}$.

TR Modules

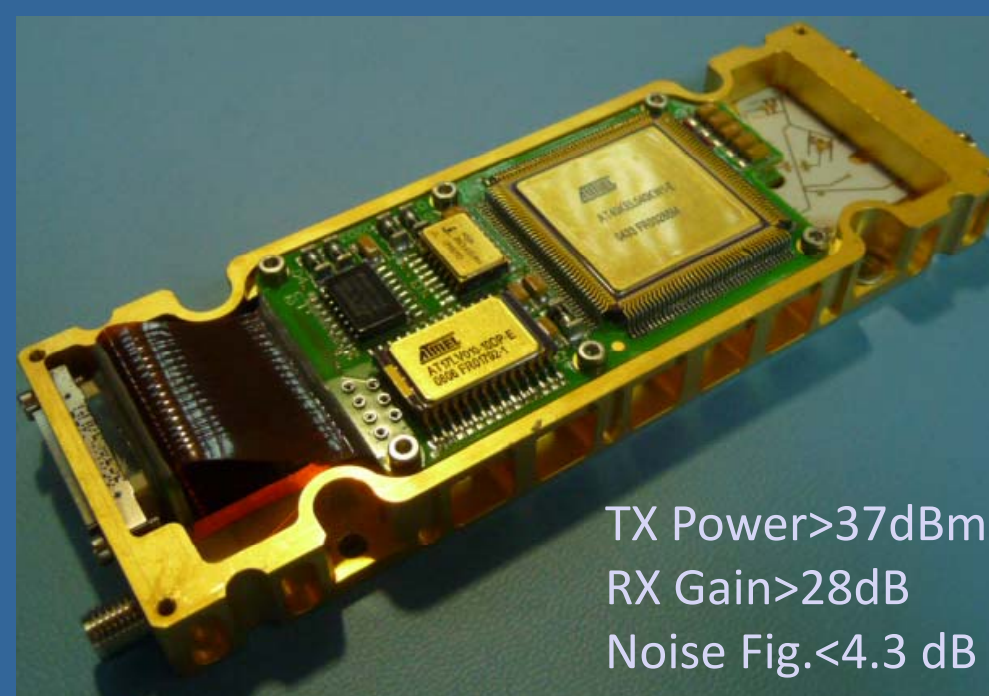

Figure 2-3 TR Module

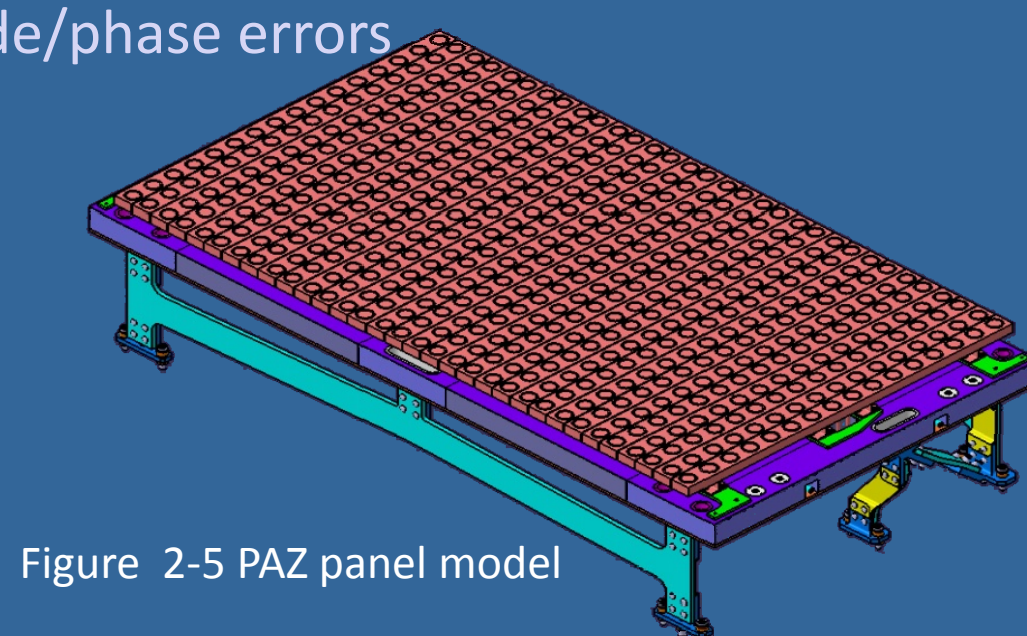

Figure 2-5 PAZ panel model

4. Instrument Performance

Antenna Model

An accurate knowledge of SAR radiation patterns is needed for precise on-ground image processing and data products calibration. End-to-end calibration shall take minimum operation time minimizing performance degradations and long re-calibration periods.

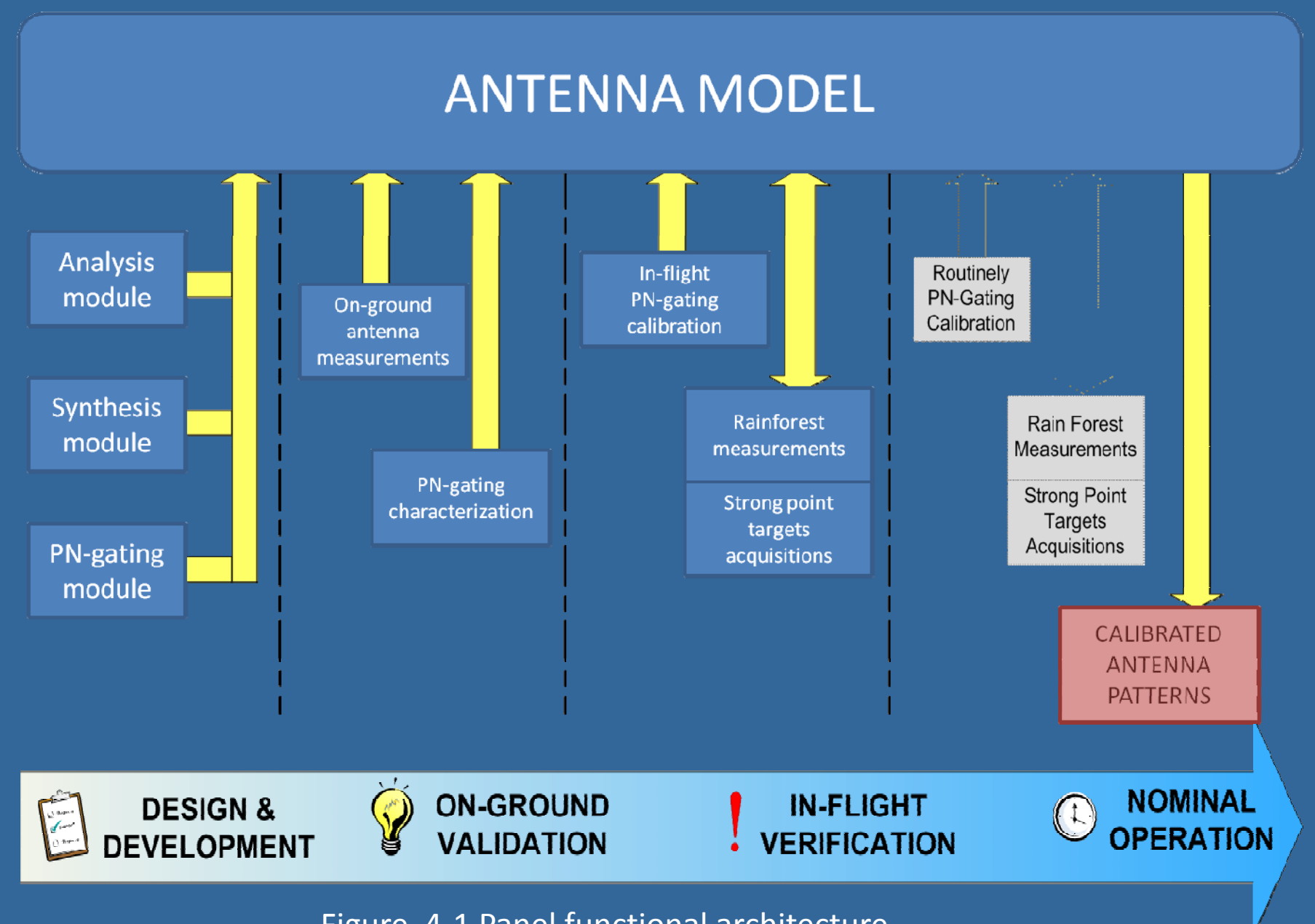

Figure 4-1 Panel functional architecture

Validation & Verification

Each performance parameter is verified by review of design, analysis or test of a set of contributions. These contributions are addressed in a first approximation at Panel qualification level.

Stripmap-Single Performance Requirements			
Parameter	Value	First results	
Polarization	HH, VV	✓	
Full performance angle range	20° - 45°	✓	
Data collection angle range	15° - 45°	✓	
Azimuth resolution	≤ 3m	✓	
Range resolution	≤ 3m	✓	
Swath	≥ 30 km	✓	
NESZ (worst case)	≤ -19 dB	Swath-3	Swath-14
RASR (worst case)	≤ -17 dB	-19.5 dB	-21.2 dB
AASR	≤ -17 dB	-26.0 dB	-25.9 dB
Radiometric stability	≤ 0.5 dB	0.20 dB	0.10 dB
Relative radiometric accuracy	≤ 0.5 dB	0.31 dB	0.22 dB
Absolute radiometric accuracy	≤ 1 dB	0.57 dB	0.34 dB
Phase stability (50 sec. window)	≤ 5 degrees	4.37 ± 0.48 degrees	

Table 4-1 SM-S performance requirements

5. Conclusions

- Consolidated panel design to allow for full performance compliance of customer requirements
- System calibration and accurate characterization measurements of antenna patterns and subsystems to validate on-ground instrument performances

6. References

- [1] F. Cerezo, M. Fernández, A. Borges, J. Sánchez-Palma, J. Lomba, R. Trigo, J. Ureña, E. Vez, M. López, 'The Spanish Earth Observation Programme', Advanced RF Sensors and Remote Sensing Instruments 2009
- [2] F. Monjas Sanz, M. I. Martín-Hervás, 'Dual polarized subarray for Spaceborne SAR at X-band', EUCAP 2009
- [3] M. Labriola, J.M. Gonzalez Arbesu, J. Romeu, I. Calafell, J. Closa, P. Saameno, J. Sanchez, A. Solana, 'AMOR: an Antenna MOdeleR for the Spanish SAR Satellite (PAZ)', Advanced RF Sensors and Remote Sensing Instruments 2009, Noordwijk, November 2009
- [4] P. Saameño, J. Closa, M. Labriola, J. Sánchez Palma, A. Solana, F. López Dekker, A. García Mondejar, A. Broquetas, 'Radiometric Budget Characterization of X-Band SAR Instrument On-Board PAZ', Advanced RF Sensors and Remote Sensing Instruments, 2009