

FDR4VGT : towards a 20+ years harmonised data record of land surface reflectances derived from VGT-1, VGT-2 and Proba-V sensors

Fabrizio Niro

ESA UNCLASSIFIED - For Official Use



Motivations



- Land global-daily monitoring from the VEGETATION programme (SPOT-VGT-1, SPOT-VGT2, PROBA-V) has led to **20+ years** of uninterrupted observations in the VNIR/SWIR range (1998 – 2020).
- The radiometric, geometric and spectral **consistency** of the three sensors and the temporal stability of the long-term archive remain to be assessed.
- Per-pixel **uncertainties** are not estimated.
- A **metrological approach**, following the guidelines developed in FIDUCEO, is essential for reliably quantifying anthropogenic trends in the derived records of terrestrial ECVs, such as the ones generated in the framework of ESA CCI and Copernicus C3S.



SPOT-VGT1, VGT-2, PROBA-V time series

Bridging the gap to S-3 for Land applications

Sentinel-3B

Sentinel-3A



SPOT-VGT1



SPOT-VGT2



Proba-V







Global near-daily coverage

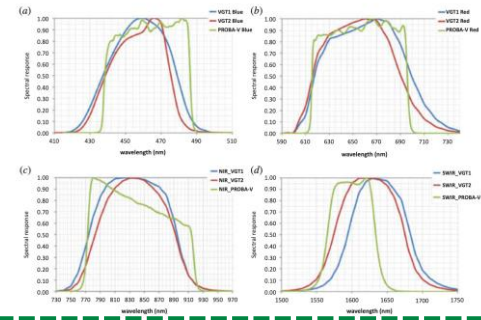

Blue, Red, NIR, SWIR bands



A **Fundamental Data Record (FDR)** is a record, of sufficient duration for its application, of **uncertainty-quantified** sensor observations **calibrated** to physical units and located in time and space, together with all ancillary and lower-level instrument data used to calibrate and locate the observations and to estimate uncertainty.

-  Long → multidecadal
-  Stabilised → combining results from multiple sensors (harmonised)
-  Uncertainty quantified → to propagate uncertainties to the next level
-  Calibrated to physical units and located in time and space → ready to be used for higher level products generation
-  With all instrument and ancillary data used to calibrate and to determine uncertainty → with what is needed for long term data preservation

<https://qa4eo.org/>



- The Quality Assurance framework for Earth Observation (QA4EO)
- Looks to make the GUM accessible to the EO community

Traceability for reliable climate information

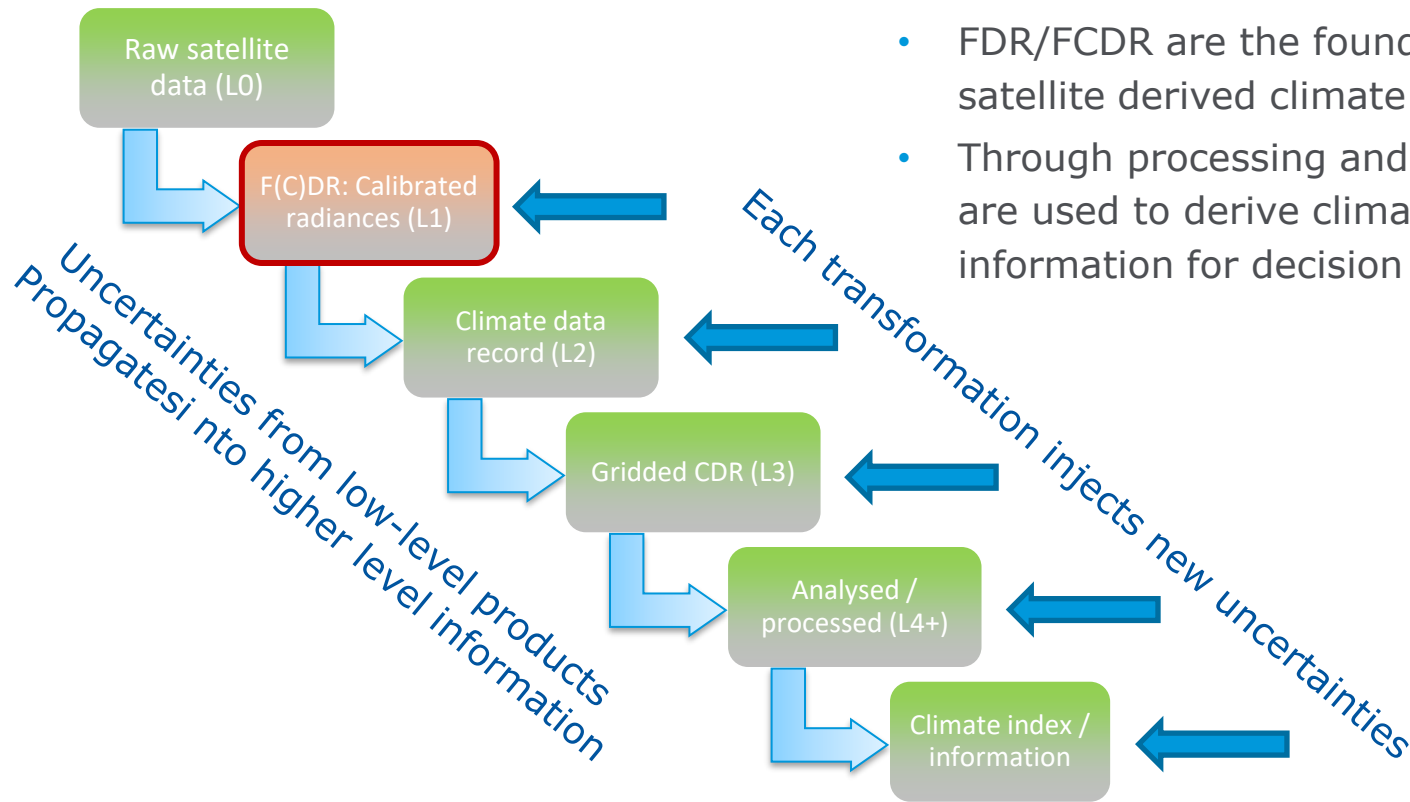

- FDR/FCDR are the foundation of all satellite derived climate information.
- Through processing and analysis they are used to derive climate information for decision makers

Metrological steps to FDR



Define the
measurand
and
measurement
function



Establish the
traceability
with a diagram



Evaluate each
source of
uncertainty
and fill out an
effects table



If appropriate
recalibrate /
harmonise
against a
reference



Calculate the
data product
and
uncertainties



Store relevant
information in
a Full FDR for
future users

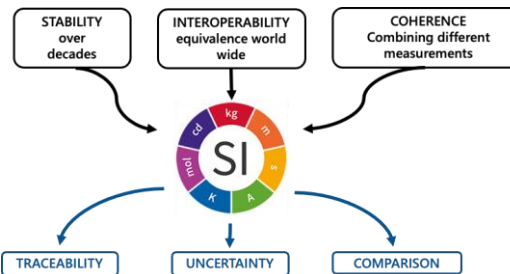

Uncertainty analysis

- Uncertainty analysis starts by identifying the **measurement function** f , which links the measurand y to the input quantities x_i .
- Given f , develop an **uncertainty tree diagram**: breaking each term down to the originating process for uncertainty.
- Once defined the sources of uncertainty, fill out an **effects table** to synthesise uncertainty/error correlation structures.

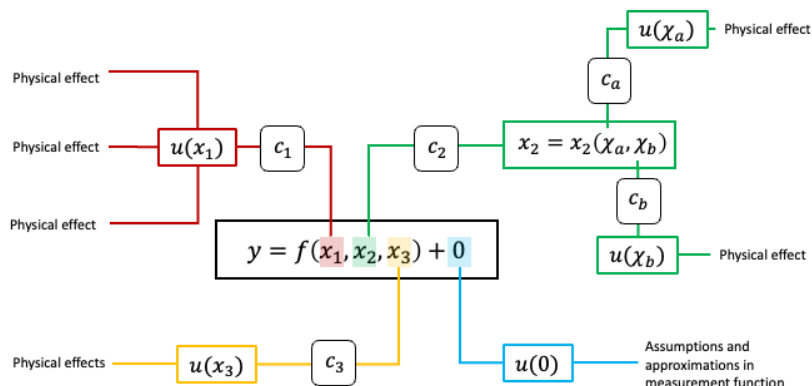

Mittaz et al. 2019

	Comments
Name of effect	A unique name
Affected term in measurement function	Name and standard symbol
Instruments in the series affected	List names
Correlation type and form	From a set of defined correlation forms
	Pixel-to-pixel [pixels]
	from scanline to scanline [scanlines]
	between images [images]
	Between orbits [orbit]
	Over time [time]
Correlation scale	As needed to define type
	Pixel-to-pixel [pixels]
	from scanline to scanline [scanlines]
	between images [images]
	Between orbits [orbit]
	Over time [time]
Channels/bands	Channel names
	List of channels / bands affected
	Error correlation coefficient matrix
Uncertainty	Functional form
	PDF shape
	units
	Units
	magnitude
Sensitivity coefficient	Value, equation or parameterisation of sensitivity of measurand to term

- The SPAR@MEP project demonstrates the interest of the VGT-1/2 PROBA-V time series for the generation of climate-relevant thematic data record of aerosol and surface properties.
- **Two main benefits** of this dataset:
 - Global coverage with **wide swath** sensor (>2000km), dense sampling in the angular domain (after accumulation) good information content;
 - **Long time series** (starting before MODIS era), with similar sensors, allowing to bridge the gap from AVHRR to Sentinel-3.
- Several **limitations** were identified and discrepancies across the sensors, mostly related to the **poor knowledge** about radiometric and geometric characterisation for those sensors, notably for VGT-1 and VGT-2

FDR4VGT project builds on SPAR@MEP lessons learned and on the best practices and methods developed within FIDUCEO, with the following **objectives**:

- Ensuring long-term data **preservation** and **valorisation** of SPOT-VGT1, SPOT-VGT-2 and PROBA-V data archives;
- Improving **consistency**, by fully characterising the radiometric, geometric and spectral differences across sensors;
- Enhancing **harmonisation** and temporal **stability** by quantifying and correcting inter-sensors biases and sensor-induced spurious drifts;
- Providing **uncertainty estimates** at pixel level, ensuring **traceability** along the full processing chain, starting from raw data;
- Generating a temporally stable and **harmonised data record** of reflectances at TOA level to be used as input for climate studies.

Implementation Approach



- **Phase 1 (2023-25)** : development of the **algorithms** for the Level 1c data processing and for inter-sensors biases assessment and uncertainties estimation; delivery of SW, ATBD and Validation Report
 - Budget availability now confirmed
 - SoW is consolidated after internal review within ESA
 - Direct negotiation with VITO + Rayference
 - Expected start in Q2/Q3 2023 for 2 years
- **Phase 2 (2025-27)**: integration of the prototype algorithm in the target platform @VITO and reprocessing/validation of the 20+ years archive.
 - The SW delivered in Ph.1 will be directly deployed in the operational platform and the processing will start for the full archive
 - Validation will be carried out at global scale over the full archive



FDR4VGT Phase 1: Key Principles



Fiduceo

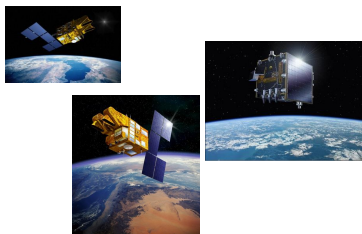
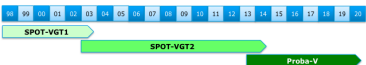
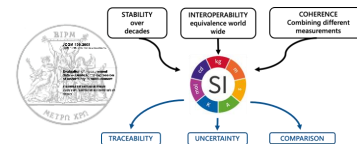

• Ready for FDR
→ Processing performances !

• FIDUCEO, GUM best practices
• Uncertainty per pixel at L1c

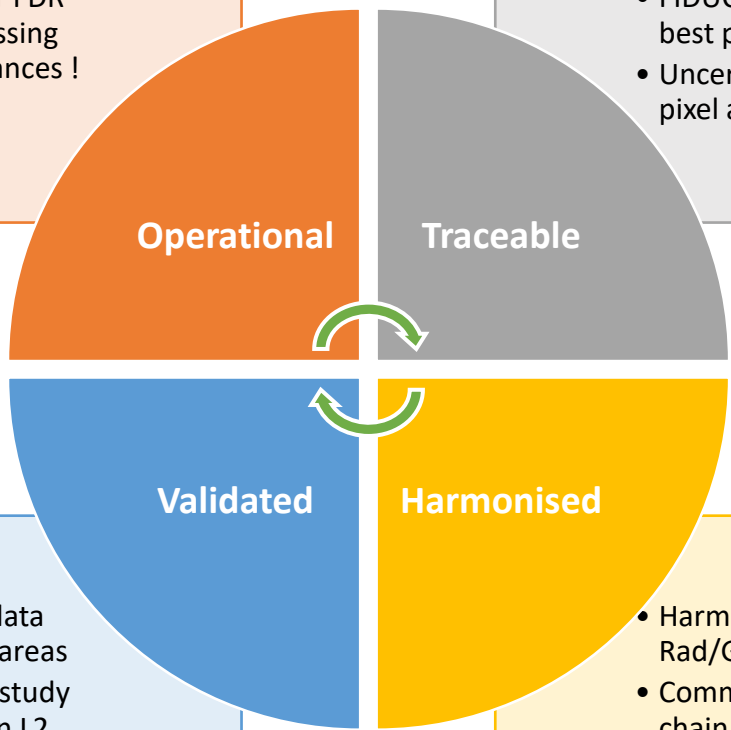

• L1c Val. data over key areas
• CISAR to study impact on L2

• Harmonized Rad/Geo Cal.
• Common L1c chain for VGT/PV

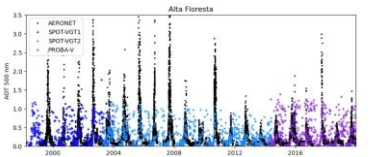
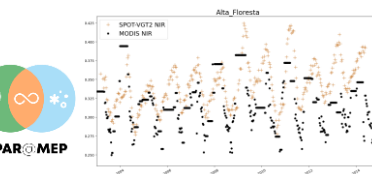
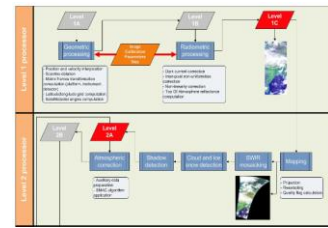
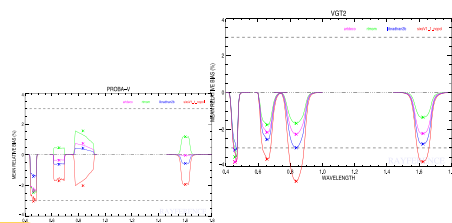

FDR4VGT Phase 1 steps

SPOT-VGT-1
Level 0

SPOT-VGT-2
Level 0

PROBA-V
Level 0

Fiduceo

Uncertainty per-pixel +
Radiometric, Geometric
Harmonisation

Harmonised
Level 1c
(**Level 1b**)



Uncertainty propagation
+ Harmonised projection
and quality flagging

Harmonised
Level 2A
(**Level 1c**)

Input:

- Fiduceo best practices
- Calibration acquisitions
- Measurement equations
- Sensor/platform model
- Pre-flight Cal/Char data
- Common set of GCPs (Sentinel-2 GRI)
- Common Solar model (Coddington et al. 2021)
- Common geometric radiometric proc. chain

Input:

- GUM best practices
- Common DEM (Copernicus)
- Common Mapping algorithm
- Common Flagging (cloud, snow/ice, shadow) algorithm

FDR4VGT Phase 1 steps

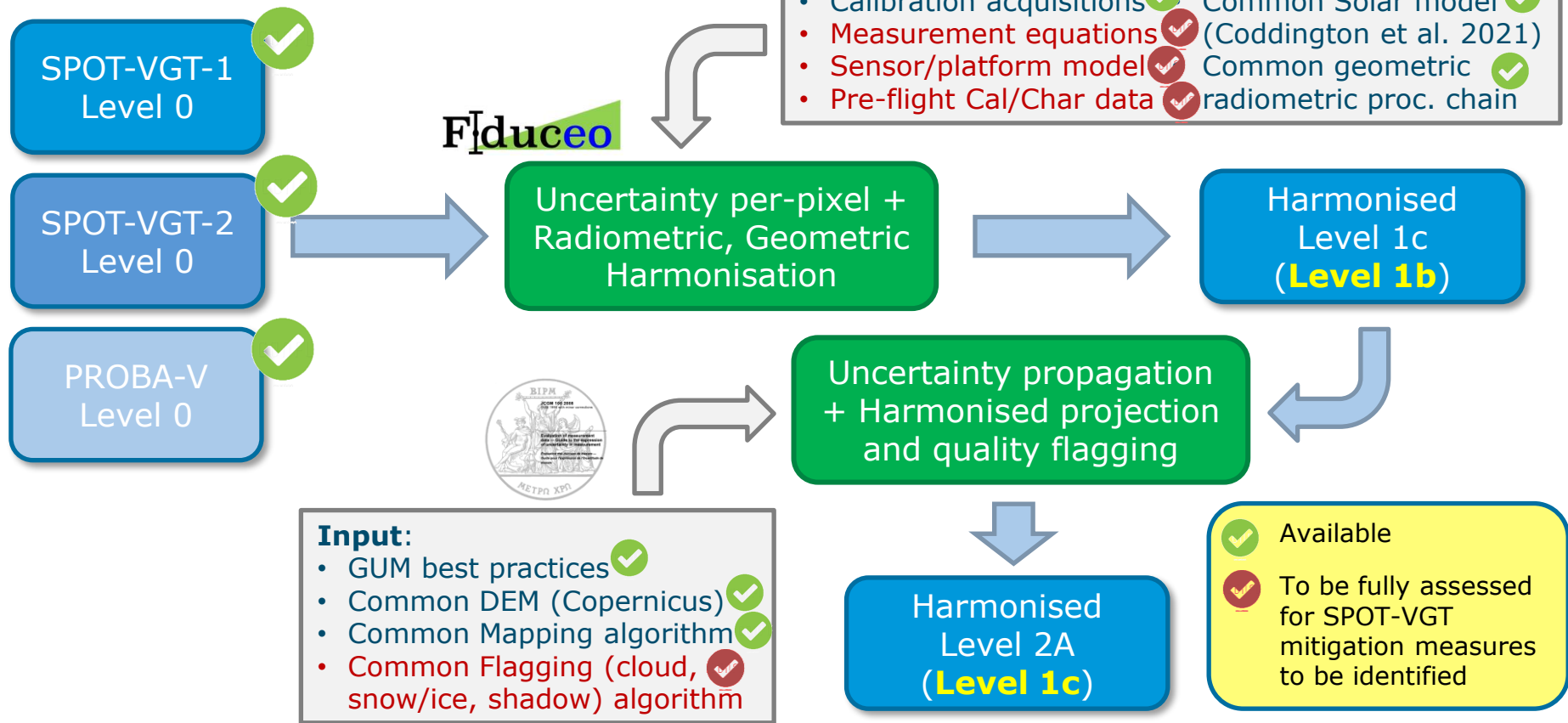

FDR4VGT Phase 1 Tasks and Timeline

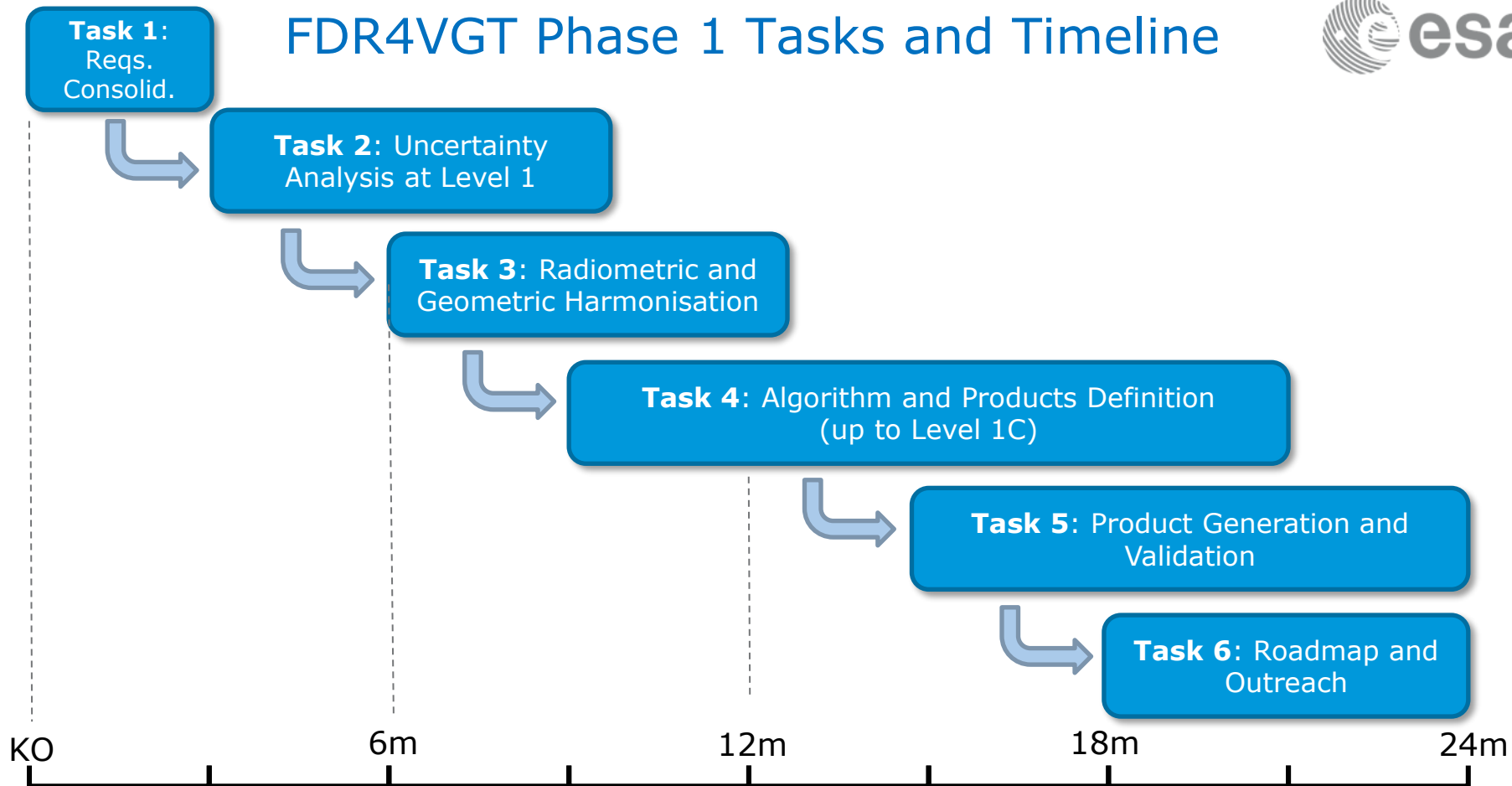

FDR4VGT Phase 1 Main Deliverables

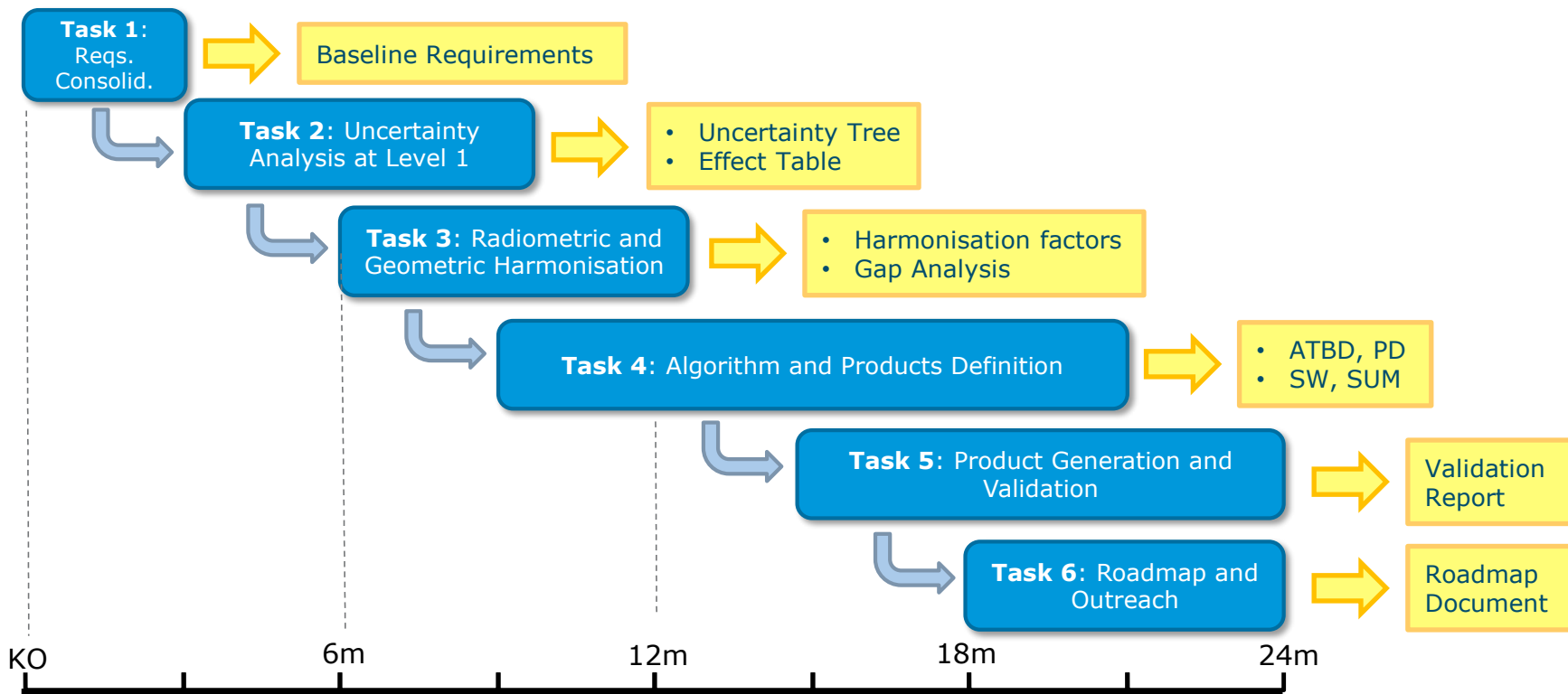

Conclusion and Outlook



- Application of metrological practices to EO (traceability and uncertainty) is key to ensure **trustworthy climate information** for decision making.
- **Uncertainty analysis** starts from the measurement equation by identifying and characterizing any potential source of uncertainties, which are then propagated through the various processing steps.
- **Uncertainty at pixel level** at Level 1 (calibrated radiances/reflectances) is crucial for proper exploitation of these measurements in retrieval algorithms and for assimilation into physical models.
- The **FIDUCEO** project developed best practices and tools to ensure proper application of metrological guidelines in EO; **FDR4VGT** will build on these practices to derive a consistent and harmonised FDR of reflectances at TOA level for use in climate applications.



Thank you! Q&A



ESA UNCLASSIFIED - For Official Use



European Space Agency

© ESA-BELSP © 2016, produced by VITO