

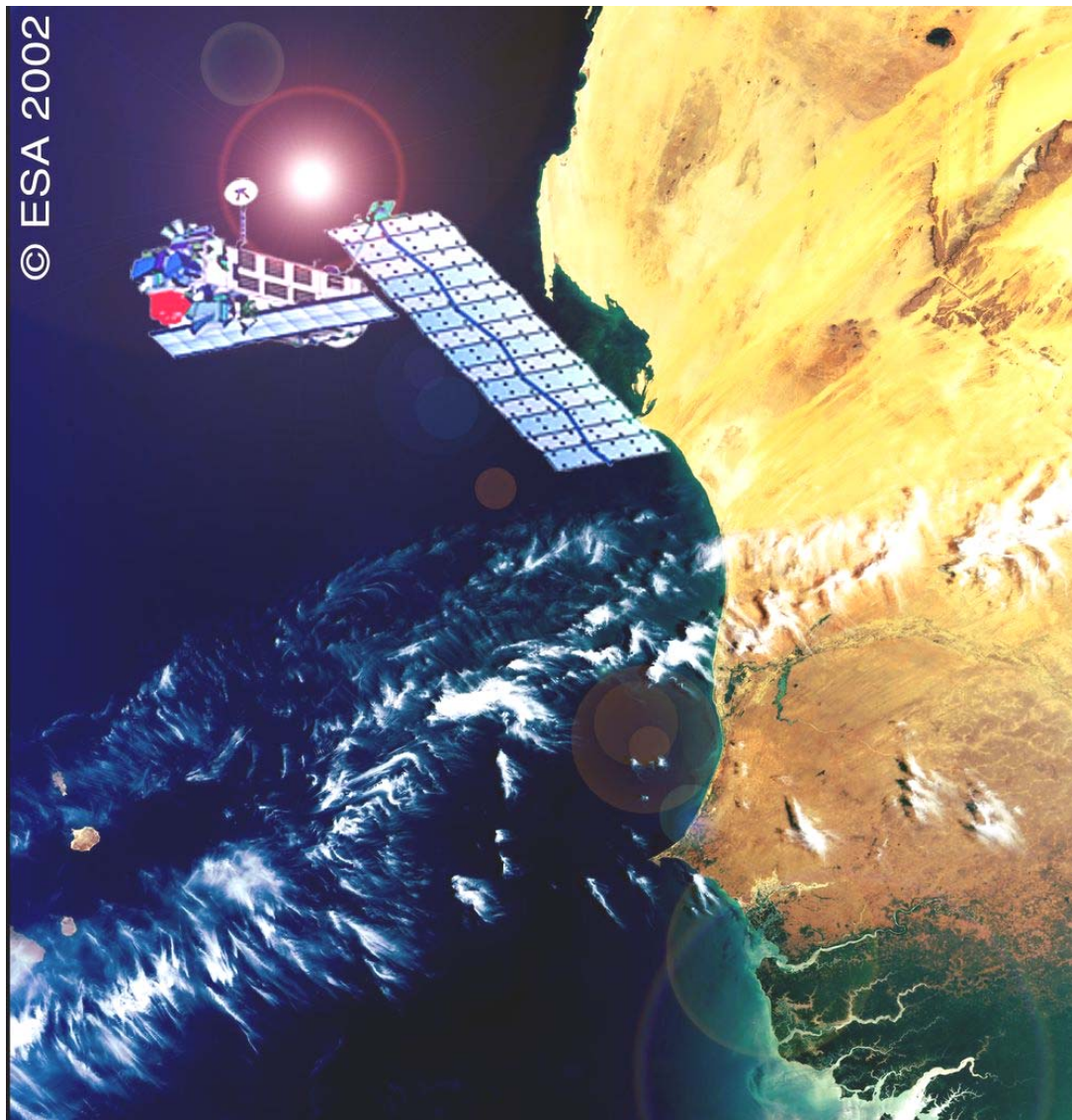

MERIS Detailed Instrument Description



European Space Agency –MERIS Detailed Instrument Description
Issue 1.0, 14th April 2006



copyright 2000-2006, European Space Agency, All rights reserved.

Table of contents

Chapter 1	Payload Description, Position on the Platform	8
1.1	Payload Description	8
1.2	Position on Platform	10
Chapter 2	Instrument Functionality	11
2.1	Calibration Mechanism (CM)	12
2.1.1	Selection disk	13
2.1.2	Radiometric Diffuser 1	14
2.1.3	Radiometric Diffuser 2	14
2.1.4	Doped Diffuser	15
2.1.5	Baffles	15
2.2	Scrambling Window Subassembly (SWSA)	16
2.2.1	UV Filter	16
2.2.2	Scrambling Window Element	16
2.2.3	Folding Mirror Element	17
2.3	Camera Optics Subassembly (COSA)	17
2.3.1	Ground Imager	20
2.3.2	Spectrometer	21
2.4	Focal Plane Assembly (FPA)	22
2.4.1	CCD Interfaces	22
2.4.2	CCD Characteristics	22
2.4.2.1	Spectral bands and CCD	24
2.4.3	Image acquisition	25
2.4.3.1	Effect of alignment parameters	25
2.4.3.2	Effect of spectral band programming	26
2.4.4	Peltier cooler	26
2.4.5	Detection Box (DB)	26
2.4.6	Detection Supply Unit (DSU)	27
2.5	Video Electronic Unit (VEU)	27
2.5.1	VEU Interfaces	29
2.5.2	VEU Sequencer	29
2.5.2.1	Image Synchronisation	29
2.5.3	Video Chains	31
2.5.3.1	VEU Gains	31
2.5.3.2	Offset Control Loop	32
2.5.3.3	Coarse offset coefficients in source packets	33
2.6	Science Data Processing SubSystem (SDPSS)	33
2.6.1	Sequencer Function	34
2.6.2	DPC Function	34
2.6.2.1	Spectral Relaxation Principle	35
2.6.2.2	Offset Correction Principle	35
2.6.2.3	Smear Correction Principle	35
2.6.2.4	Gain Correction Principle	36
2.6.2.5	Spatial and Temporal Relaxation Principle	36
2.6.3	DPC Processing in Measurement and Stabilisation Modes	37

2.6.4	SDPSS Processing in Transition to On Ground Calibration Mode	38
2.6.5	MBR / LBR Formatting	38
2.7	Instrument Control Unit (ICU)	39
2.8	Power Distribution Unit (PDU)	40
2.8.1	Equipment Powering	40
2.8.2	CM Motor Powering	41
2.8.3	Telemetry	41
2.9	Digital Bus Unit (DBU)	41
2.10	Thermal Control	42
Chapter 3	Internal Data Flow	43

List of figures

Figure 1.1 - MERIS calibration.....	9
Figure 1.2 - Location of MERIS on ENVISAT.	10
Figure 1.3 - MERIS instrument.....	10
Figure 2.1 - Functional block diagram of MERIS.....	12
Figure 2.2 - Diffuser disk (seen from above -Z for the upper view).	14
Figure 2.3 - Doped diffuser spectral response.....	15
Figure 2.4 - Polarisation Scrambling Window.....	17
Figure 2.5 - MERIS optical layout.....	18
Figure 2.6 - COSA disposition.....	19
Figure 2.7 - MERIS ground imager and spectrometer optical design.....	20
Figure 2.8 - CCD / refracting block configuration.....	21
Figure 2.9 - CCD array.	23
Figure 2.10 - Hierarchical relations for spectral bands in the CCD.	24
Figure 2.11 - Effect of alignment parameters on the imaging area position.	25
Figure 2.12 - VEU sequencers, VCs and DUs configuration.....	28
Figure 2.13 - Synchronisation signals between the VEU and the SDPSS.....	30
Figure 2.14 - Microband in input of the VEU video chains.....	31
Figure 2.15 - Processing performed by a VEU video chain.....	31
Figure 2.16 - DPC processing.....	34
Figure 2.17 - Spatial and time relaxation process.	37
Figure 2.18 - DBU layout.....	42
Figure 3.1 - Overview of optical path and signal processing in transition to calibration mode.....	44
Figure 3.2 - Overview of optical path and signal processing in measurement or stabilisation mode.....	45

List of tables

Table 2.1 - Light output of the CM according to the disk position.	13
Table 2.2 - CCD interfaces.....	22
Table 2.3 - Spectral bands default values in ROM.....	24
Table 2.4 - Input/output correspondence of detection boxes.....	26
Table 2.5 - DSU interfaces.....	27
Table 2.6 - VEU interfaces.....	29
Table 2.7 - SDPSS processing in Measurement and Stabilisation modes.....	37

Abstract

This *MERIS Detailed Instrument Description* document provides information about the Envisat platform, each part of the MERIS instrument and internal data flow.

In order to access faster to the information, another document, the *Frequently Asked Questions* may be used.

A more detailed description is provided in the *MERIS Product Handbook* which guides users to choose and use MERIS data and explains the way these data are processed and organised.

Scientists may also get a deeper and more detailed level of information in the other documents pointed as reference in the *MERIS Product Handbook*.

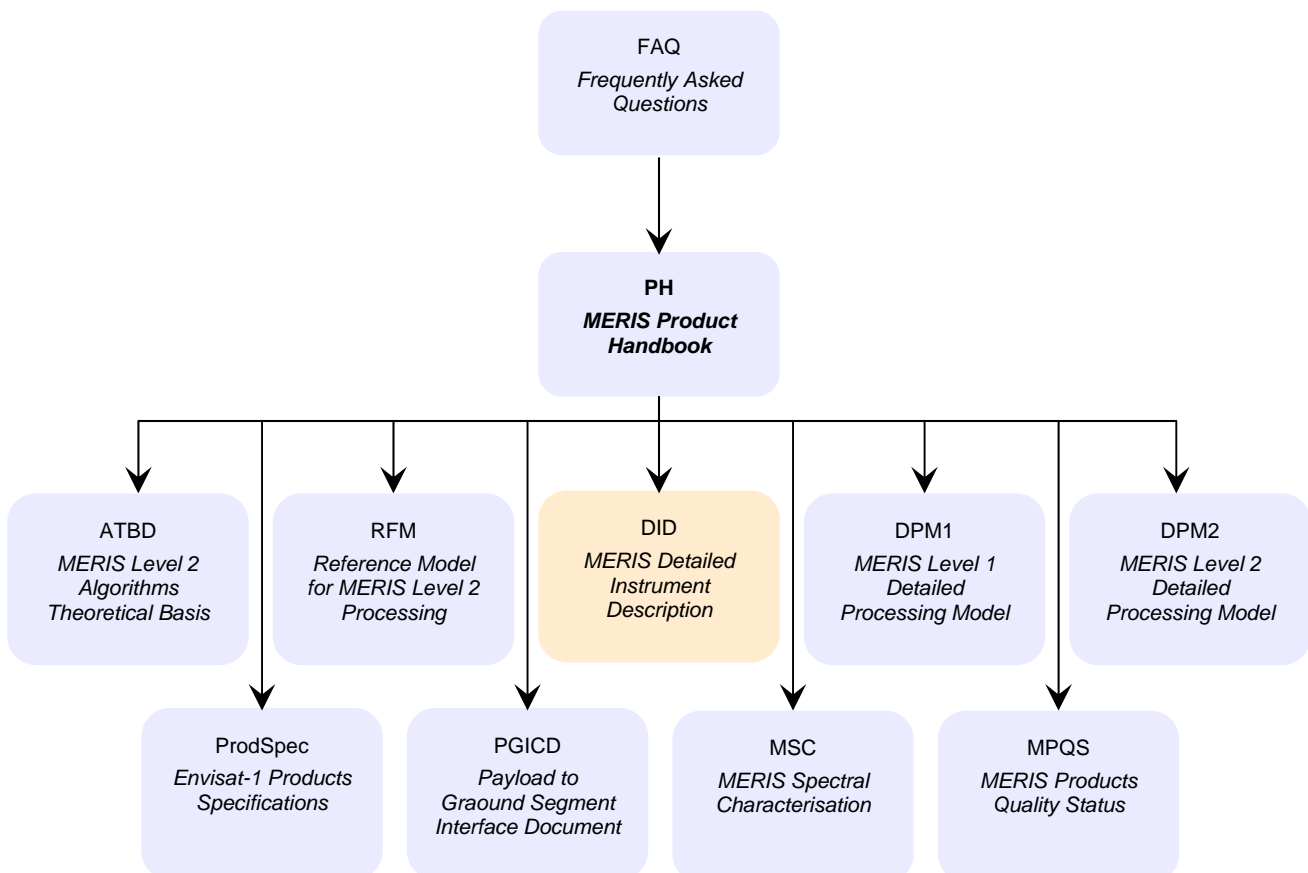

Chapter 1

Payload Description, Position on the Platform

1.1 Payload Description

MERIS is a programmable, medium-spectral resolution, imaging [spectrometer](#) operating in the solar reflective spectral range of visible and near infrared light. Fifteen spectral bands can be selected by ground command, each of which has a programmable width and a programmable location in the 390 nm to 1040 nm spectral range.

The instrument scans the Earth's surface by the so called "push-broom" method. [CCD](#) arrays provide spatial sampling in the [across-track](#) direction, while the satellite's motion provides scanning in the [along-track](#) direction.

MERIS is designed so that it can acquire data over the Earth whenever illumination conditions are suitable. The instrument's 68.5° field of view around *nadir* covers a swath width of 1150 km. This wide field of view is shared between five identical optical modules arranged in a fan shape configuration. In the calibration mode, correction parameters such as offset and gain are generated, which are then used to correct the recorded spectra. This correction can be carried out either onboard or on the ground.

The Earth is imaged with a spatial resolution of 300 m (at nadir). This resolution is reduced to 1200 m by the onboard combination of four adjacent samples *across-track* over four successive lines.

The scene is imaged simultaneously across the entire spectral range, through a dispersing system, onto the *CCD* array. Signals read out from the CCD pass through several processing steps in order to achieve the required image quality. These CCD processing tasks include dumping of spectral information from unwanted bands, and spectral integration to obtain the required bandwidth. Onboard analogue electronics perform pre-amplification of the signal and correlated double sampling and gain adjustment before digitisation. The onboard digital electronics system has three major functions: it completes the spectral integration, performs offset and gain corrections in full processed mode, and creates the reduced-resolution data when required.

The calibration of MERIS is performed at the orbital south pole, where the calibration diffuser is illuminated by the Sun by rotating a calibration mechanism (see [figure3.1](#)).

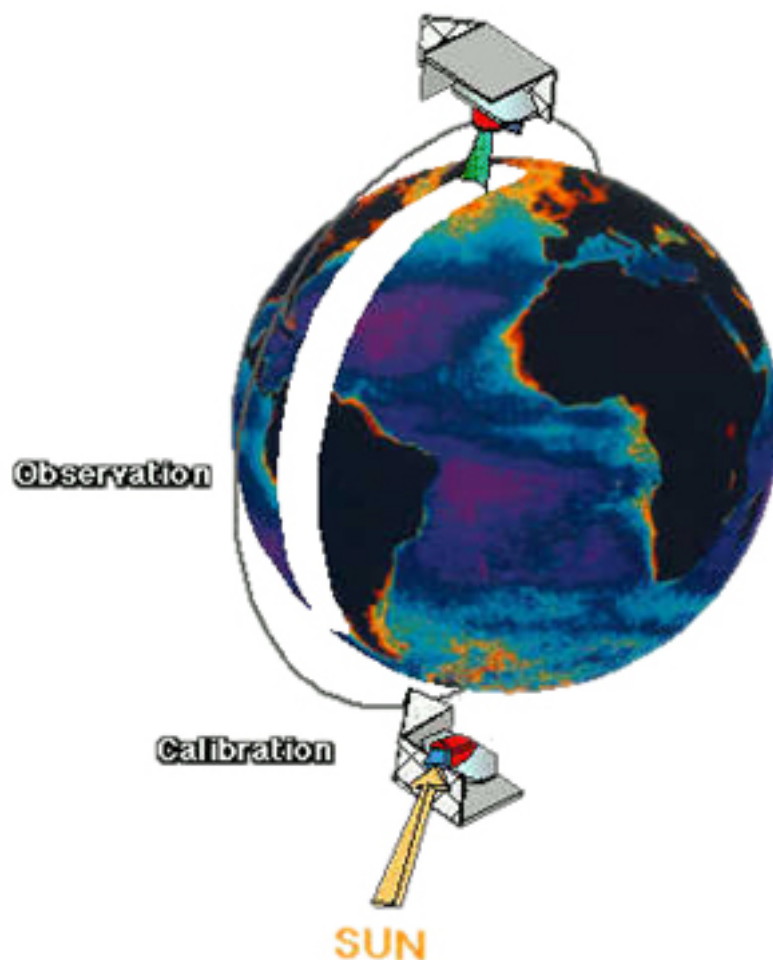

Figure 1.1 - MERIS calibration.

1.2 Position on Platform

[Figure3.2](#) shows the location of the MERIS (in red) on ENVISAT.

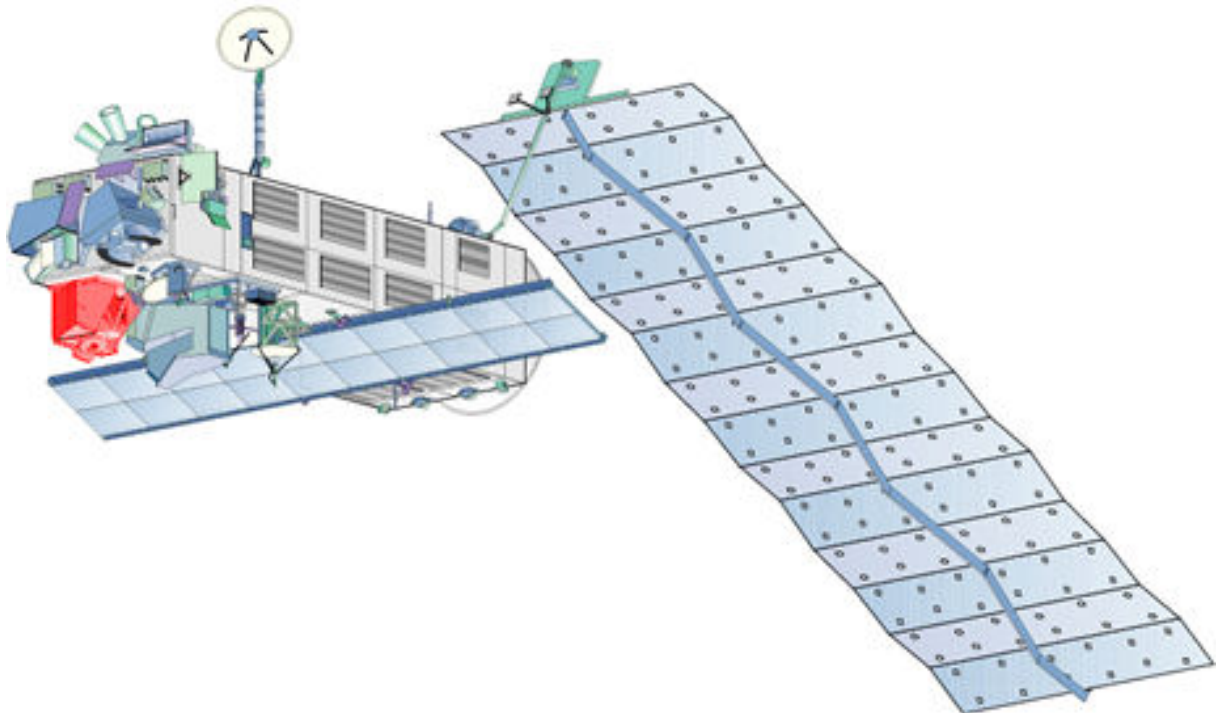

Figure 1.2 - Location of MERIS on ENVISAT.

[Figure3.3](#) shows the MERIS instrument.



Figure 1.3 - MERIS instrument.

Chapter 2

Instrument Functionality

The main instrument subsystems are:

- Calibration Mechanism (CM)
- Scrambling Window Subassembly (SWSA)
- Camera Optics Subassembly (COSA)
- Focal Plane Assembly (FPA)
- Video Electronic Unit (VEU)
- Science Data Processing Subsystem (SDPSS)
- Instrument Control Unit (ICU)
- Power Distribution Unit (PDU)
- Digital Bus Unit (DBU)
- Thermal Control

The following diagram shows the major functional components of MERIS:

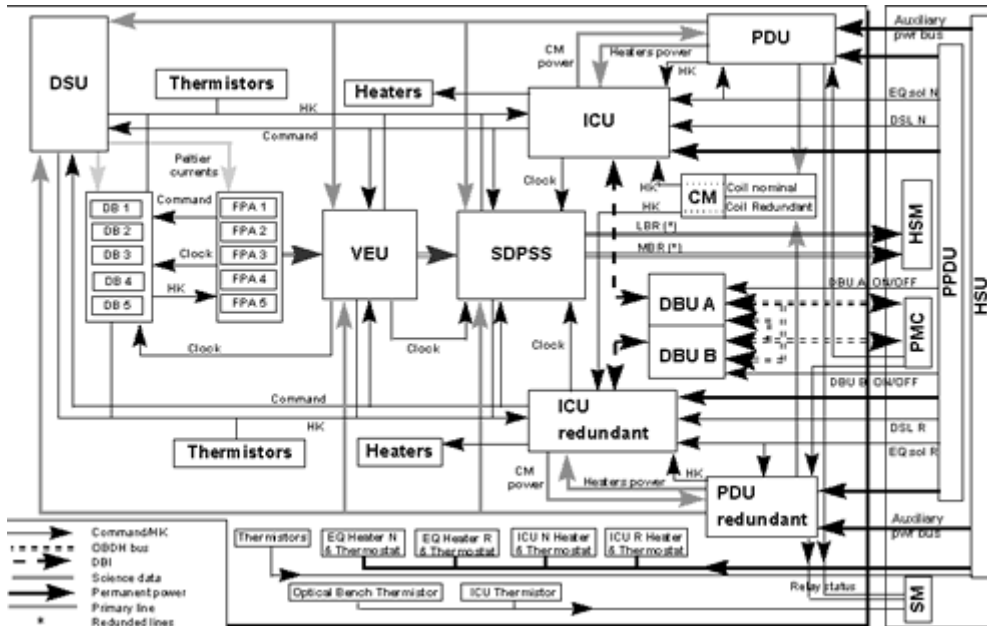

Figure 2.1 - Functional block diagram of MERIS.

2.1 Calibration Mechanism (CM)

This device is used for the calibration of MERIS.

If considered as a "black box", the [CM](#) receives the light from the Earth and from the Sun, and the light output depends on the mode (observation or calibration), and on the present step in this calibration or observation sequence.

In practice, the main features of the [CM](#) are as follows (refer to [figure3.5](#)):

- One aperture on the -Z direction, oriented towards the Earth for observation.
- One aperture on the +Y direction, oriented towards the Sun in the orbital south pole region, during the calibration phase.
- A stepper motor and a selection disk directly mounted on its shaft. The motor can be rotated to change the selection disk position with regard to the apertures. The selection disk has 5 stable positions as shown in Figure 1 below, which correspond to the 5 types of light output, as detailed in Table 1 below.
- Two optocoders to measure the selection disk position (one nominal optocoder connected to the nominal [ICU](#), and one cold redundant optocoder connected to the redundant ICU). The position is reported in telemetry parameter E4508.

2.1.1 Selection disk

The selection disk (seen in [figure3.5](#) below from above -Z axis) supports the following pieces of equipment:

- Observation window, which is just an aperture in the selection disk, in order to minimise the stray light coming from the Earth.
- Radiometric diffuser 1.
- Radiometric diffuser 2.
- Doped diffuser.
- Earth shutter, which is a physical piece of opaque material on the selection disk.

According to the selection disk position, the light coming from the Earth or from the Sun can be used or blocked, and this results in a [CM](#) light output as in the table.

Table 2.1 - Light output of the CM according to the disk position.

Disk position	Relative position	Sun light	Earth light
Observation window	0°	Blocked	Directly transmitted
Radiometric diffuser 1	-72°	Diffused Sun light	Blocked
Radiometric diffuser 2	-144°	Diffused Sun light	Blocked
Earth Shutter	72°	Blocked	Blocked
Doped diffuser	144°	Diffused Sun light	Blocked

Note 1: As implied in [table 3.1](#), the diffusers are opaque and only their reflective properties of the Sun light (characterised by their [BRDF](#)) are used.

Note 2: The "relative position in degrees" refers to the relative position on the disk, with a convention of 0° for the observation window, and, with the disk seen from above -Z axis, angles positive in the clockwise direction.

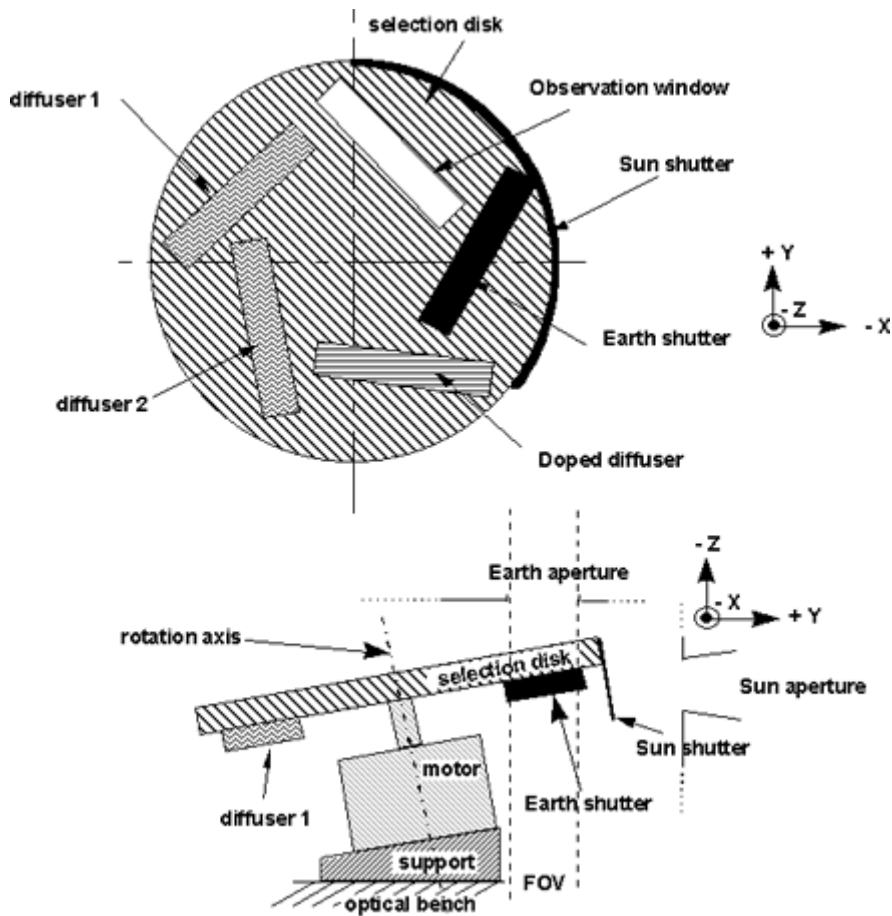

Figure 2.2 - Diffuser disk (seen from above -Z for the upper view).

2.1.2 Radiometric Diffuser 1

This diffuser is a part of the calibration hardware, and is made of "Spectralon". It is used in most of the calibration phases. During the concerned calibrations, the diffuser is exposed to the Sun, and the light diffused by reflection by the diffuser is used as an input for processing. The characteristics of the diffused light ([BRDF](#)) is precisely determined on ground before the launch.

2.1.3 Radiometric Diffuser 2

This diffuser is identical to the radiometric diffuser 1. However, it is used only during the "Diffuser ageing" calibration to monitor the ageing of diffuser 1. Indeed, diffuser 1 degrades because of repeated exposure to the space environment, while the optical properties of diffuser 2 can be assumed unchanged all over the mission, because it is far less used than diffuser 1 (degradation is negligible).

2.1.4 Doped Diffuser

This diffuser is a part of the calibration hardware, and is a diffuser doped with rare earth elements. When illuminated by the Sun, the diffused light spectrum obtained after the diffuser presents characteristic spectral peaks, the wavelength of which can be precisely determined ([figure3.6](#)). This diffuser is used during wavelength calibrations.

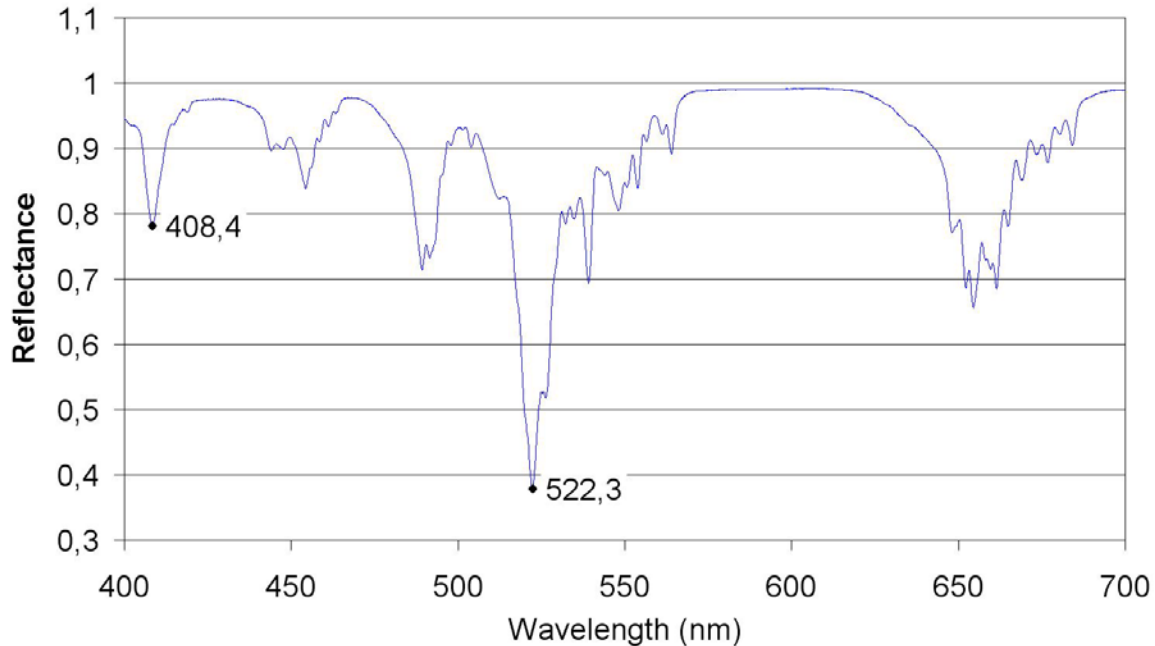

Figure 2.3 - Doped diffuser spectral response.

2.1.5 Baffles

Baffles are used to protect the camera optics subassembly against undesired light from the Earth or the Sun.

An internal baffle is implemented to reduce flux of Earth light entering the optical system. The object of the baffle in general is to reduce stray light in the Earth image formed in the optical system.

The location for the external baffle aperture, considering only control of stray light, is at the crossover point of the optical axes of the camera modules.

Internal baffles are implemented between the camera, the folding mirror, the window assembly and the calibration hardware to minimise stray light.

2.2 Scrambling Window Subassembly (SWSA)

For a better understanding of this section, see [figure3.7](#). The [SWSA](#) consists of a Scrambling Window Element (SWE) and a Folding Mirror Element (FME).

It receives the light from the Calibration Mechanism (CM) and outputs this light to the 5 Camera Optics Subassemblies (COSAs).

Its function is to:

- Depolarise the light using 5 scrambling windows (one for each [COSA](#)) via [SWE](#).
- Reflect the [UV](#) light via SWE.
- Reflect the depolarised light perpendicularly to the input light signal, towards the COSA, using 5 folding mirrors (one for each COSA) via [FME](#).

The depolarisation is required because the light coming from the Earth could be polarised. Due to the optical properties of the folding mirror and [COSA](#), the radiance of the reflected light would be reduced (and therefore would not be representative of the observed scene) if the light was not depolarised before reaching the mirror.

2.2.1 UV Filter

The first optical surface of the instrument is an uncoated bulk absorption [UV](#) filter whose purpose is the protection the rest of the optical parts from reflected solar ultraviolet radiation.

2.2.2 Scrambling Window Element

[SWEs](#) are located at the entrance pupils of the camera modules. The SWE faces are orthogonal to the axes of their respective camera modules, as reflected by the [FME](#) in its mean Earth-view rotation. SWEs are used to reduce the effective polarisation of the instrument. Each SWE consists of two quartz crystal wedges and one fused silica wedge, the three wedges cemented together. The quartz wedges provide the required depolarising effect. The fused silica wedge is designed in such a way that the SWE external faces are parallel (see [figure3.7](#)).

For the following explanations, an essential distinction is made between the *optical axis*, which is a geometric axis of the imaging optics, and the so called *optic axis*, which is a quartz crystallographic axis. The quartz crystal *optic axis* in each wedge is in the [SWE](#) plane, and orthogonal to the camera module optical axis.

Quartz has the property to alter the polarisation state of the transmitted light, the change in polarisation state depending on the thickness of quartz. Consequently, the shape given to the quartz wedge produces a change in polarisation state which varies across the optical aperture. This effectively depolarises the transmitted light.

The depolarising effect of a single wedge varies with the polarisation direction of the incident light beam. Maximum depolarisation is achieved for polarisation at 45 degrees or 135 degrees to the optic axis, and no depolarisation for polarisation at 0 or 90 degrees to the optic axis. Two wedges are

required with an angle of 45 degrees between their optic axes to provide effective depolarisation for any incident polarisation direction.

The depolarising effect is a function of wedge angles, larger angles producing more cycles in change of polarisation state across an optical aperture of given dimensions. However, each quartz wedge produces a split in the ground image, which has the effect of reducing the ground image resolution: the two quartz wedges together produce four images in a square array.

Consequently, wedge angles have been selected to provide acceptable degradation on resolution with acceptable effective depolarisation.

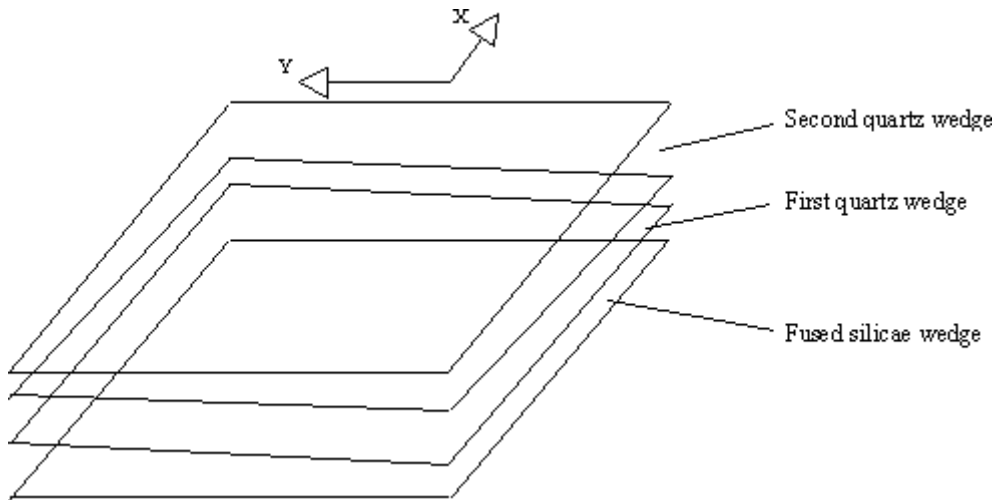

Figure 2.4 - Polarisation Scrambling Window.

The lines with highest angle of slope of the quartz wedges are oriented respectively at + and - 45 degrees to the instrument Y (*across-track*) axis for the first and the second wedge (equally inclined to the axis of symmetry of the optical aperture to give similar depolarising effects for all incident polarisation directions).

2.2.3 Folding Mirror Element

Each folding mirror (*FME*) is a flat, front-surface coated mirror, which receives light from Earth, via the associated *SWE*, and reflects the light into the associated camera module (*COSA*).

2.3 Camera Optics Subassembly (COSA)

MERIS includes 5 *COSAs*, and each *COSA* is located in relation to the *SWSA*, *CM*, and associated *FPA* as shown in [figure3.8](#).

Each *COSA* includes a ground imager and a *spectrometer*.

The ground imager collects the light through an external slit, and forms an Earth image of this slit in the entry of the spectrometer.

Then the spectrometer disperses the light and forms a dispersed image of the slit on a [CCD](#) array (this CCD array is not a part of [COSA](#), but of [FPA](#)). The resulting image of the slit is bi-dimensional: one dimension corresponds to the spatial extension of the slit, and the other dimension corresponds to the decomposition of light into all its spectral components from the visible to near infrared (390 nm to 1040 nm).

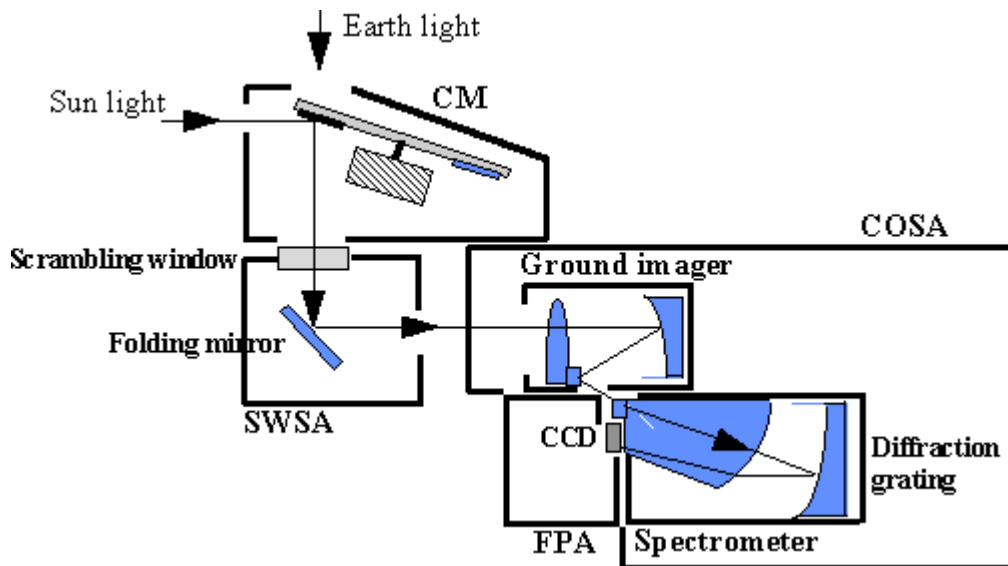

Figure 2.5 - MERIS optical layout.

Each [COSA](#) has a 14 degrees [FOV](#), and the 5 COSAs are disposed as in Figure 2 to obtain an InFOV of 68°.

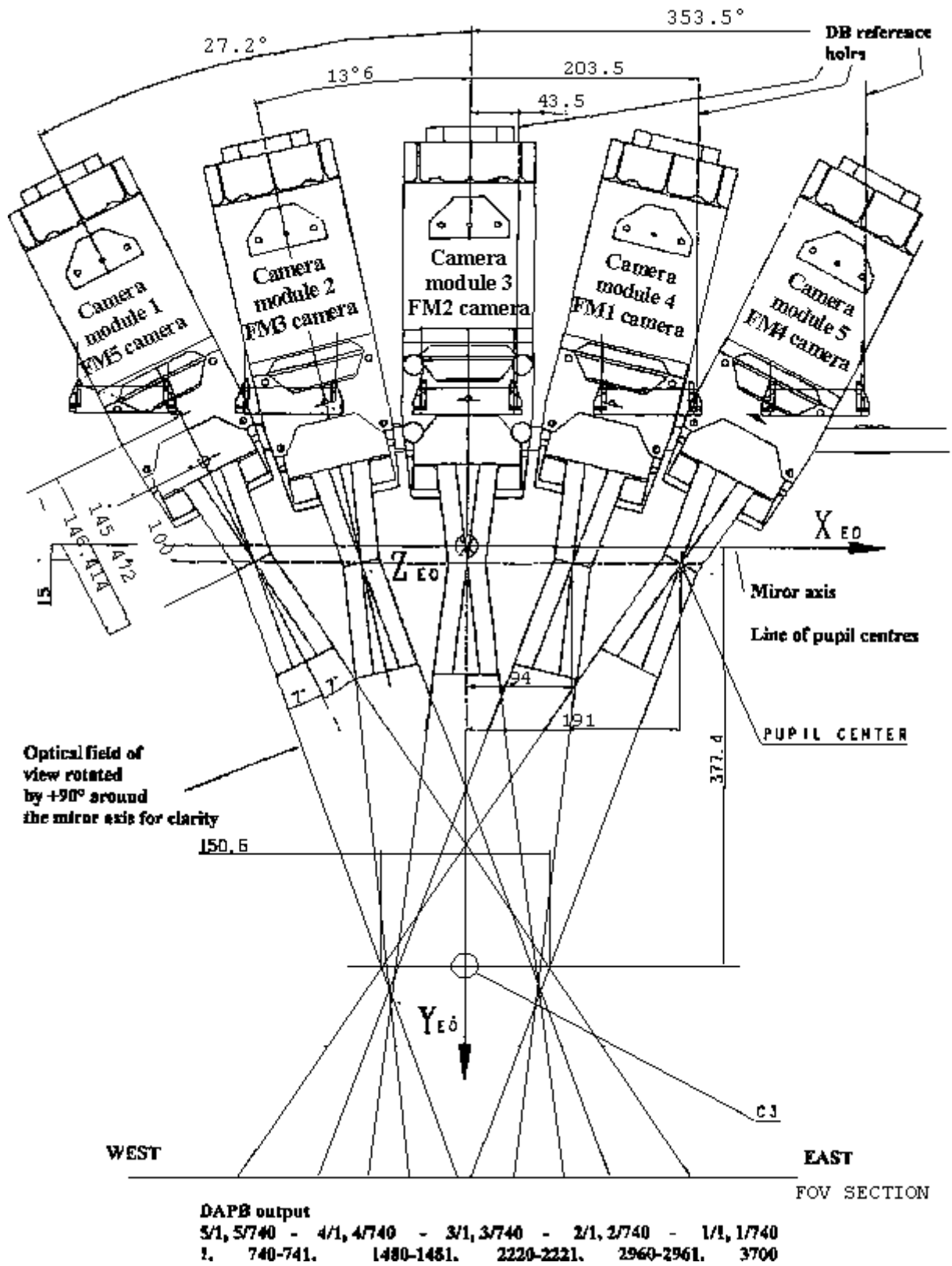

Figure 2.6 - COSA disposition.

2.3.1 Ground Imager

The ground imager is basically an off-axis catadioptric system, consisting of (following the light path):

- Three large lenses made of fused silica.
- A concave primary mirror.
- A convex secondary mirror.
- Field lens, made of fused silica, at the image plane.

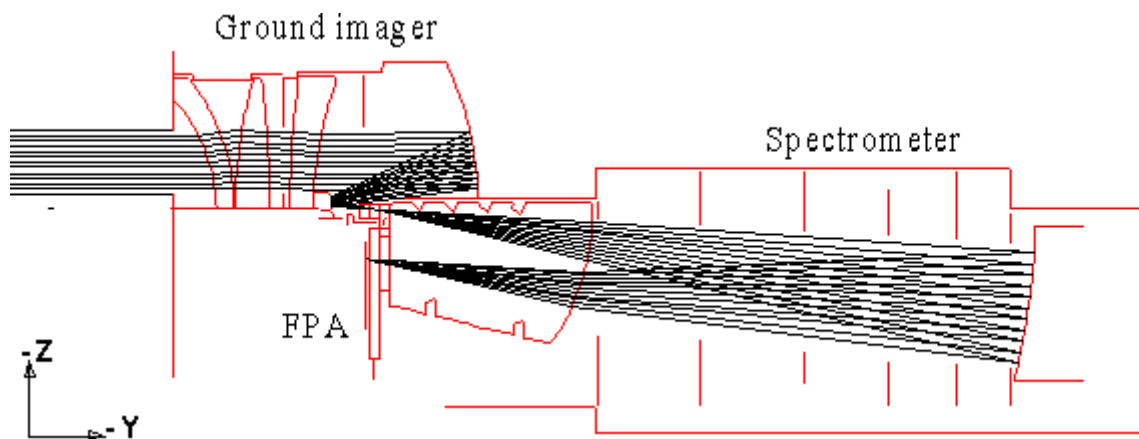

Figure 2.7 - MERIS ground imager and spectrometer optical design.

The catadioptric system is corrected for a 50 mm diameter entrance pupil area. However, the used area of the entrance pupil is limited to an approximately rectangular area 20 mm x 32 mm, as sketched in [figure3.11](#).

Reminder: the entrance pupil and pupil of the ground imager are not physical apertures, but relate to the image shape at the entrance and within the ground imager.

The catadioptric system entrance pupil is located at 88 mm from lens surface. This allows the entrance pupil to be close to the outer surface of the Scrambling Window - with space for the folding mirror between the Scrambling Window and the cameras.

The pupil of the ground imager is not physically defined by an aperture near the Scrambling Window, but by the aperture of the diffraction grating in the [spectrometer](#). (The entrance pupil plane is imaged nominally to infinity by the ground imager itself, and reimaged onto the diffraction grating by the refracting corrector of the spectrometer.)

The focal length of the ground imager is 67.3 mm, so that it images a 260 m ground pixel onto a 22.5 micron spectrometer entrance slit width, from a nominal altitude of 800 km.

The design has a flat image surface and is telecentric.

The lenses have anti-reflection coating optimised for spectral range 390-1,040 nm. Moreover, the external face of the first lens has an inverse filter in order to optimise the instrument spectral responsivity (including optical transmission, spectrometer diffraction grating, [CCD](#) responsivity) for radiometric performances.

2.3.2 Spectrometer

The spectrometer mainly consists of a refracting block and a concave reflecting diffraction grating, as shown in [figure3.12](#).

The spectrometer entrance slit is located near the diffraction grating centre of curvature, on a flat face of the refracting block. The opposite outer face of the block is spherical, and is concentric with the diffraction grating.

This concentric optical system forms a dispersed image of the entrance slit in the plane of the flat face on which the entrance slit is formed. The [CCD](#) array is located close to this face to collect the dispersed image.

A blocking filter is included in the construction of the spectrometer refracting block, in order to block second order spectrum of the diffraction grating (see Figure 5). The concept is a prism in RG610 (i.e., a colour filter glass) located on the front face of the [CCD](#). The gap between the blocking filter outer face and the CCD window is 0.13 mm, and between the CCD and its window is 1 mm. The edge of the prism disturbs the spectral MTF in the range 675-715 nm.

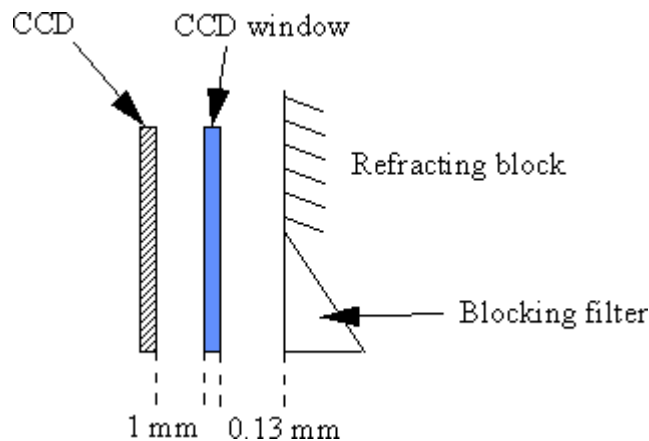

Figure 2.8 - CCD / refracting block configuration.

The spectrometer works at "unit magnification" in each wavelength, which means that a square of side 22.5 microns at the entrance slit (corresponding to a 260 m x 260 m Earth area at subsatellite point, at 800 km altitude) is imaged as a square of side 22.5 microns on the [CCD](#).

The radius of curvature of the grating is 199 mm. The grating disperses a 1.25 nm wavelength interval across one 22.5 micron [CCD](#) element.

The entrance slit with black shielding is a straight slit. It is imaged as a straight line in each wavelength on a [CCD](#) elementary spectral line. 520 CCD elementary spectral lines are dedicated to the nominal spectral bandwidth of the instrument - 390 nm to 1,040 nm. 740 CCD columns are assigned to the nominal 14 degree field width of each camera module. The line spectrum of each point in the ground imager, formed on the entrance slit and reimaged by the spectrometer, is a straight line parallel with a CCD column.

With the pupil of the system at the diffraction grating, the system is telecentric at both the object and image planes. Due to off axis optical design, the beam is tilted at 11 degrees.

This off-axis arrangement is selected so that the light reflected from the [CCD](#) does not return to the diffraction grating (from which some of it would be reimaged onto the CCD).

The refracting block of the spectrometer is made of fused silica, to improve the correction of the spectrometer for aberrations of the dispersed image.

2.4 Focal Plane Assembly (FPA)

For a better understanding of this section, refer to [COSA Figure3.8](#).

Each of the 5 [FPAs](#) is composed of a [CCD](#) array and a Peltier cooler, used to maintain the CCD in its operational temperature range.

2.4.1 CCD Interfaces

Table 2.2 - CCD interfaces.

Input	Output
- CCD power from DU	- Image data to VEU
- Clock line from DU	- Temperature of CCD to DU

2.4.2 CCD Characteristics

The [CCD](#) array converts the light coming from the [COSA](#) into an electrical analogue signal.

The selected [CCD](#) is a thinned, back illuminated, frame transfer CCD, made of 814 x 1152 detector elements, but only 740 x 520 detector elements imaging area are used for the MERIS images (see [figure3.13](#)). Each detector element has a size of 22.5 µm x 22.5 µm, and it corresponds to one pixel in the image data.

- Each line composed of 740 pixels corresponds to the spatial image of the entrance pupil at a given wavelength.
- Each column of 520 detector elements corresponds to the spectral image of a pixel of the entrance pupil at all wavelengths in the 390 nm to 1040 nm range.

Consequently, each pixel in the image represents 260 m (spatial image) x 1.25 nm (spectral image).

The remaining detector elements of the [CCD](#) (surrounding the image area) are dispatched as follows:

Left and right sides

- 10 transition pixels width on both sides of the imaging area, to take into account the possible misalignment with the mask which limits the imaging zone.
- 5 pixels width on both sides, which are shielded in any case, and used to protect the dark pixels against charge contamination.
- 5 dark pixels width on both sides of the imaging area. The 5 dark pixels transmitted first to the [VEU](#) at the beginning of the elementary spectral line are used to monitor and correct the undesired offset effects which alter the image. This correction is achieved by the VEU offset control loop. The 5 dark pixels transmitted to the VEU at the end of the elementary spectral line are not used for this correction.

Top and bottom

- 5 elementary spectral lines on the top and on the bottom of the imaging zone, are kept as a margin for possible shift of the spectrum with respect to the [CCD](#) (these lines are not shielded).
- 10 elementary spectral lines on the bottom of the imaging zone for possible misalignment with the mask which limits the imaging zone.
- 5 elementary spectral lines used to protect the smear band against charge contamination.
- just under the imaging zone, 31 elementary spectral lines are reserved for the smear band, which is used to correct the smear effect.

Shift register

- 17 fictive pixels on both sides of the shift register. Only 4 of these pixels are transmitted to the [VEU](#).
- the storage zone has a size of 576 x 814 pixels, to copy all previously described pixels to this storage zone.

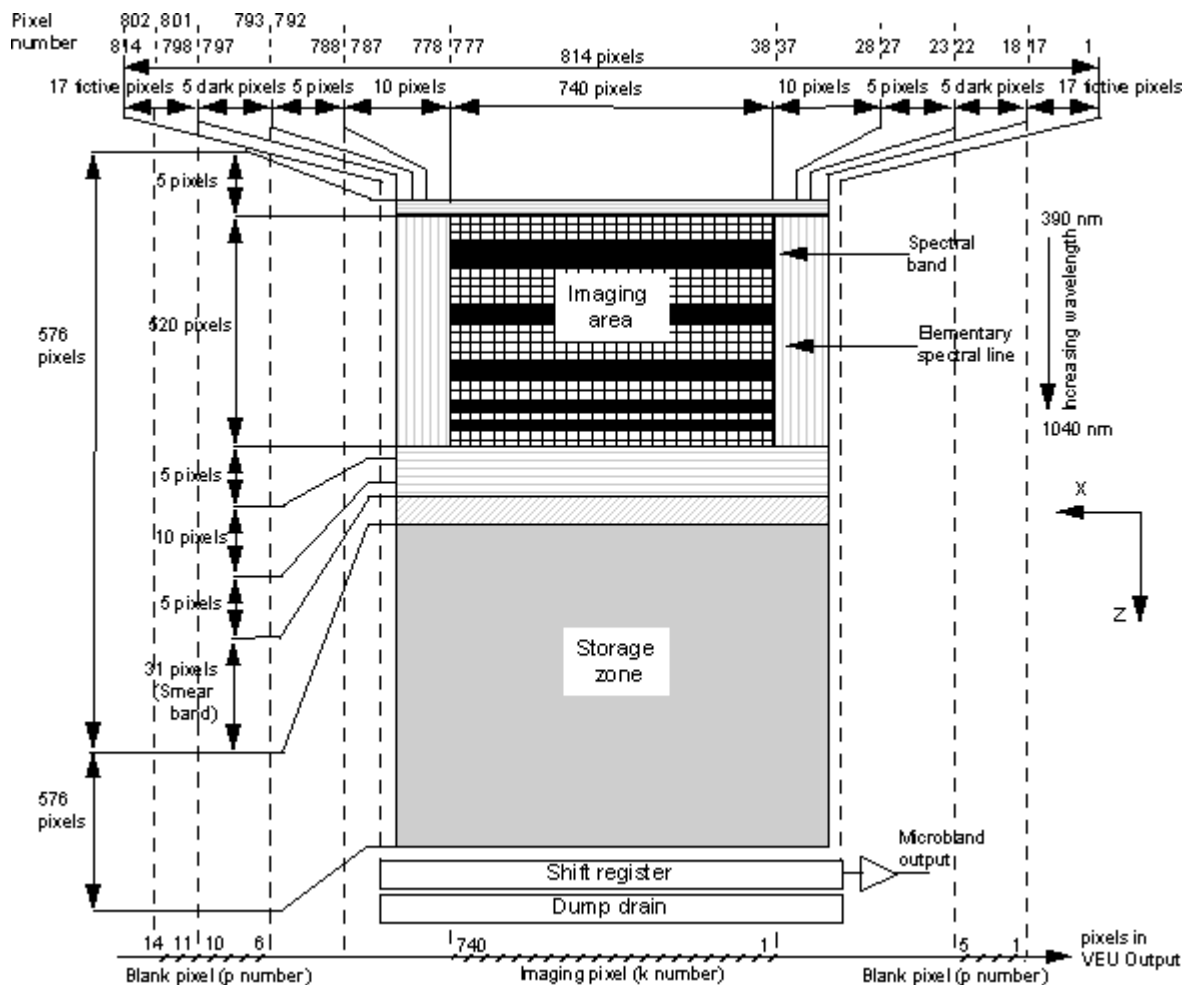

Figure 2.9 - CCD array.

Note: crosshatched pixels in [figure3.13](#) and flagged "Pixels in VEU output", do not indicate [CCD](#) output (i.e., VEU input), but indicate the pixels composing each elementary spectral line in **VEU output**. They are indicated here to show clearly where these pixels come from on the CCD array. These pixels are sent to the [SDPSS](#) and finally put in the source packets.

2.4.2.1 Spectral bands and CCD

For the understanding of the following sections, [figure3.14](#) recalls the relations between elementary spectral lines, microbands and spectral bands. The process used to constitute microbands is described more precisely in this part hereafter. The constitution of spectral bands on the basis of microbands is called spectral relaxation and is described in the [Science Data Processing Subsystem. 3.1.2.6.](#)

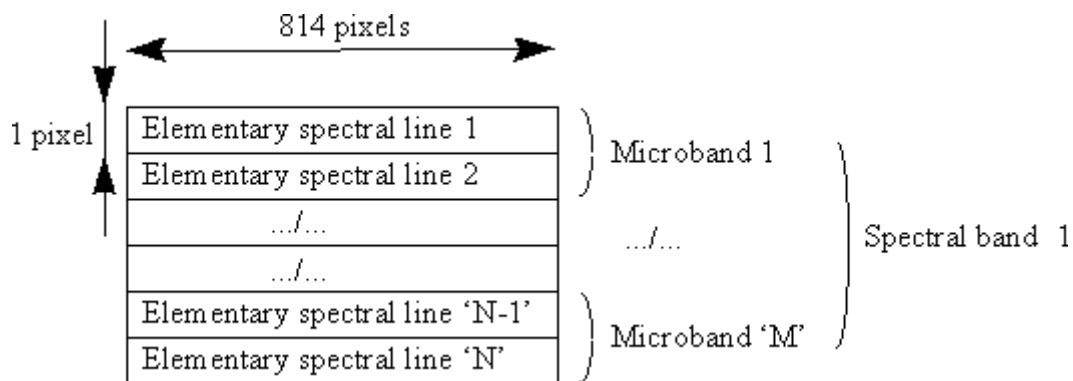

Figure 2.10 - Hierarchical relations for spectral bands in the CCD.

The default values in Read-Only Memory (ROM) for spectral bands (i.e., the number of the last line in the spectral band, between 0 and 520), number of microbands in the spectral band, and number of elementary spectral lines per microband are given in table, with the associated [VEU](#) gain (see [VEU Gains 3.1.2.5.3.1.](#)). No wavelength is indicated for the smear band (16th spectral band) because it is not an observation spectral band.

The spectral band position (given by the number of the last line in the band) is defined in the imaging area. Consequently, the spectral bands effectively observed also depend on the alignment parameter (which influence imaging area position).

Table 2.3 - Spectral bands default values in ROM.

SpectralBand ID	1	2	3	4	5	6	7	8	9	10	11	12	13	14	15	16
Number of last line in the band	22	46	84	100	140	188	224	236	256	294	297	314	384	404	412	520*
Number of microbands	2	2	2	2	4	4	4	2	4	2	1	3	4	1	1	1
Number of lines per microband	4	4	4	4	2	2	2	3	2	3	2	4	4	8	8	31
VEU Gain	1.25	1	1	1	1.75	1.5	1.5	1	1.75	1.25	2	1	1.75	1	1	3.75

(*): non-significant value for the smear band (not taken into account by the Application Software [ASW])

2.4.3 Image acquisition

After the falling edge of frame top, with a determined delay, the [CCD](#) acquires data during 42.776 msec: each detector element acquires an electrical charge. Then the electrical charges are shifted within 1.224 msec to the storage zone, protected from the incoming light by a shield.

Then, depending on the choice of **observation spectral band and alignment parameters**, some elementary spectral lines have to be kept and others have to be eliminated. The selection is made in the [CCD](#) "shift register", described below.

2.4.3.1 Effect of alignment parameters

The alignment parameter associated with the [CCD](#) (there is one such parameter per CCD) has an effect on the "shift register": the relative position of the imaging area with respect to the "shift register" is moved upward or downwards depending on the alignment parameter.

Of course, the [CCD](#) area physically exposed to light is not modified by alignment parameters. However, for the "shift register", the position of the imaging area on the CCD is as indicated in [figure3.13](#) only if **alignment parameter=0**.

If alignment parameter = N (N integer between -5 and +5), the "shift register" considers that the imaging area is shifted by N elementary spectral lines (the width of each is 1.25 nm), **upwards if N>0 and downwards if N<0**. For example, by setting "alignment parameter"=1 for camera module 2 (FM3 camera), the minimum wavelength that can be observed by this camera becomes $390.325 - 1.25 = 389.075$ nm.

Smear band is not affected by alignment parameters.

The alignment parameters have to be changed only if:

- during MERIS lifetime, the [CCD](#) moves with respect to MERIS optics
- spectral bands are desired out of the acquisition ranges specified in Acquisition Spectral Range

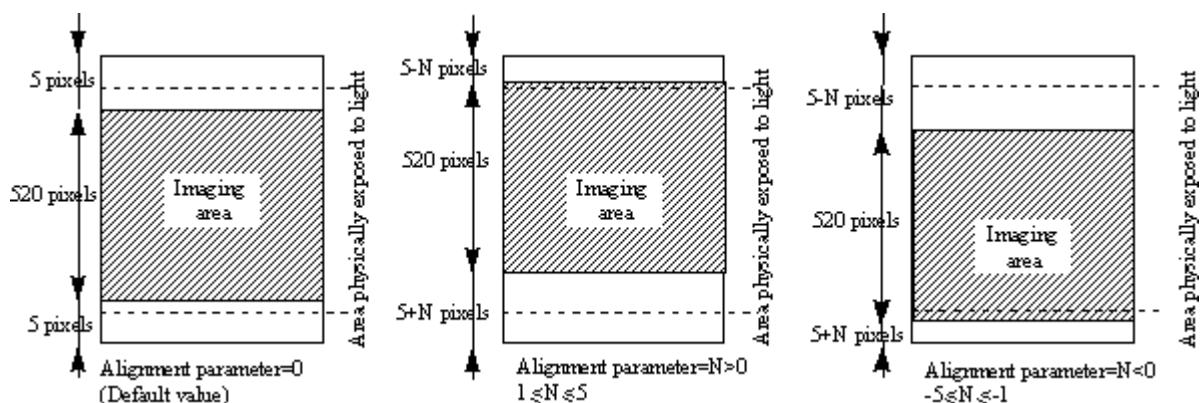

Figure 2.11 - Effect of alignment parameters on the imaging area position.

Note: An "area physically exposed to light" is mentioned in the figure to emphasise the fact that alignment parameters have no effect on the location of the area exposed to light. It is not necessarily representative of the real situation on [CCDs](#).

2.4.3.2 Effect of spectral band programming

Each elementary spectral line is moved one after the other from the storage zone into the shift register, and then:

- For the smear band and in the imaging area (located by taking into account alignment parameters), if it is included in a programmed spectral band, it is added to the other elementary spectral lines in the shift register (as long as saturation limit has not been reached) to constitute microbands consecutively. A spectral band is made of one or several microbands, and each microband is made of one or several elementary spectral lines. The number of elementary spectral lines in a microband (and as a result the number of microbands per spectral band) depends on the shift register capacity, on the incident spectral intensity and the spectral sensitivity of the detector elements involved in the microband. These characteristics are taken into account during the choice of spectral bands on ground. The microbands are the output of the shift register of the [CCD](#) array, and are sent directly to the [VEU](#).
- If it is not included in a programmed spectral band, the elementary spectral line is sent to a dump drain for elimination.

2.4.4 Peltier cooler

One Peltier cooler is associated with each [CCD](#), for the thermal regulation of the CCD within its operational temperature range. CCD temperature is nominally regulated at $-22.5^{\circ}\text{C} \pm 0.25^{\circ}\text{C}$, in order to limit dark current (i.e., noise signal on the CCD). This thermal control is based on the "Peltier effect", i.e., the temperature of the Peltier cooler can be controlled by the value of the current which circulates through it. Each Peltier cooler is powered by a dedicated line from the Detection Supply Unit (DSU).

2.4.5 Detection Box (DB)

One detection box is associated with each [CCD](#), and constitutes its command and control interface. Detection boxes do not need to be switched on. The correspondence between the input and output are as in [table 3.4](#) :

Table 2.4 - Input/output correspondence of detection boxes.

Input	Output
DC power from DSU	CCD powering
Clock signal from the VEU	CCD clock signal
Command signal from the VEU	
Thermistor line from CNTR5.htm - eph.meris.gloss.acrabr:VEUCCD	Thermistor line to ICU
(HK parameters E4520, E4521, E4522, E4523, E4524)	

The clock signal from the [VEU](#), and sent to the [CCD](#), is used to synchronise the image acquisition by the CCD and the correction made on these images by the VEU.

2.4.6 Detection Supply Unit (DSU)

Table 2.5 - DSU interfaces.

Input	Output
Unregulated power 21 / 37V from the PDU	Power to each dB
ML16 from ICU nominal	Current to each FPA PC, commanded by the ICU via ML16 / DS16 line.
ML16 from ICU redundant	DS16 to ICU nominal
	DS16 to ICU redundant

The [DSU](#) is involved in the thermal regulation loop of [CCDs](#), and powers the [DUs](#).

[DSU](#) includes:

- 2 serial I/F: 1 nominal, powered by [PDU](#) nominal and controlled by nominal [ICU](#) via [ML16/DS16](#); and 1 in cold redundancy, powered by PDU redundant and controlled by redundant ICU via ML16/DS16.
- 6 Power Supplies: 5 "in use" [PS](#) nominally used, and 1 "out of use" PS in cold redundancy. In the default configuration, PS 1 to 5 are "in use", and connected to [FPA](#) and [dB](#) 1 to 5 respectively. Any of these PS 1 to 5 can be replaced by PS 6 in case of failure.

"In use" and "out of use" [PS](#) are set by the [DSU](#) serial I/F, according to the command received from the [ICU](#) via [ML16](#).

All [PS](#) are connected to both [PDU](#) power but only "in use" PS use this power effectively. The function of each PS is to:

- send a current to the connected [FPA](#) Peltier cooler, according to the command received from the [DSU](#) serial I/F
- power the connected [dB](#)

2.5 Video Electronic Unit (VEU)

The [VEU](#) has a function only when image data is collected by MERIS; i.e., in Calibration, Measurement modes and Stabilisation modes. In other modes, the VEU is switched off.

Its function is to collect analogue image data from the [CCDs](#), to correct this data, to convert it into 12 bit digital words, and to sent it to [SDPSS](#) through serial links.

The [VEU](#) includes 6 video chains (5 nominal plus one in cold redundancy): 5 video chains are active at a given time, with one video chain associated to each [CCD](#). These video chains are controlled by a sequencer (either nominal or redundant).

The sequencer, VCs and DUs configuration is defined by internal relays: pedestal bus relays, power bus relays, fast I/F relays, and DU-I/F relays.

In the following, the sequencer, VCs and DUs configuration is detailed (see [figure3.16](#)).

Within each VC, one pedestal bus relay, one power bus relay and one fast I/F relay connects the VC to the VEU nominal sequencer or redundant sequencer. These relays can be switched by nominal or redundant sequencers.

Their function is:

- Pedestal bus relay: to connect the sequencer RAM 2 to VC for transmission of VEU coarse offset coefficients.
- Power bus relay: to power the VC.
- Fast I/F relay: to connect the VC to the sequencer for control signals.

For each DU, one DU-I/F relay connects the DU to the VEU nominal sequencer or redundant sequencer. Their function is to connect DU to the sequencer for control signals.

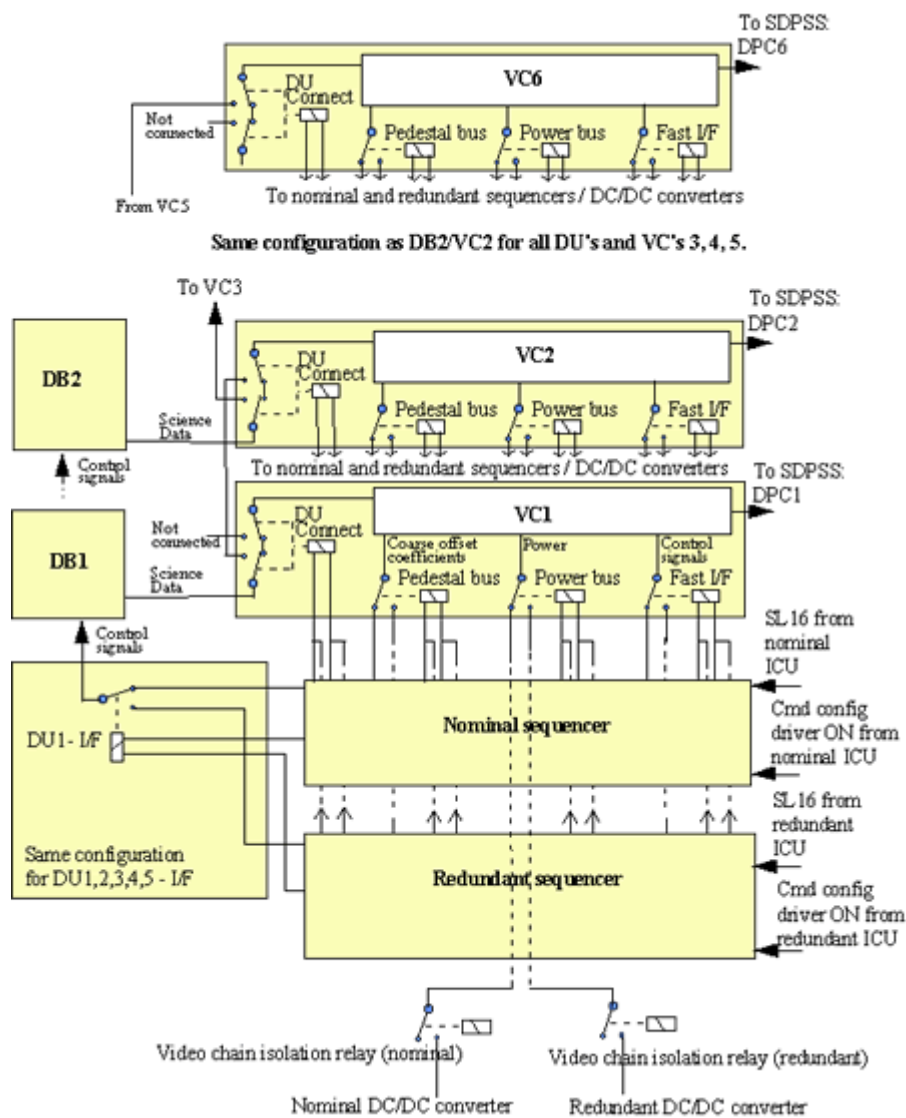

Figure 2.12 - VEU sequencers, VCs and DUs configuration.

2.5.1 VEU Interfaces

Table 2.6 - VEU interfaces.

Input	Output
5 lines from each CCD for Image data	6 Serial Link lines to SDPSS for image data
SL16 line from ICU nominal	SL16 line to ICU nominal for telemetry
SL16 line from ICU redundant	SL16 line to ICU redundant for telemetry
N/A	Clock line to SDPSS
N/A	Clock line to each DB
Power from PDU nominal	N/A
Power from PDU redundant	N/A

2.5.2 VEU Sequencer

Its function is to:

- synchronise the image acquisition (through [dB](#)) and computations (including [SDPSS](#) computations) thanks to an internal clock
- to control the [VEU](#) on the basis of the data and commands sent by the [ICU](#)
- control command for mode switching, coarse offset control loop enabled/inhibited, frame abort function active/inactive, relay configuration (see the following sections for details)
- VEU gain coefficients
- instructions defining the spectral bands

2.5.2.1 Image Synchronisation

The image synchronisation is made as soon as the [VEU](#) is in "Run" mode. Commands and clock signals are sent to each [dB](#), to control the image acquisition sequentially, this is made on the basis of instructions sent to the VEU RAM 1 by the [ICU](#).

Once the image data has been corrected by [VCs](#) (see next chapter) and converted into 12 bit words, it is stored in output registers. Then the transmission of this data to [SDPSS](#) is controlled using the synchronisation signals sent from the [VEU](#) sequencer to the SDPSS sequencer, which make it possible for the SDPSS to perform the relevant computation at the appropriate time (see [figure3.17](#)):

- Frame tops and microband tops sent from the [VEU](#) sequencer to the [SDPSS](#) sequencer via a dedicated clock line. Frame tops indicate that data is related to a given frame; microband tops indicate each microband within a frame (maximum 46 including the smear band).
- End of pixel tops and transfer tops sent from each [VC](#) to the corresponding Digital Processing Chain ([DPC](#)) through the serial link with the image data. The 3 physical lines of each serial link transmit:

- end of pixel tops, which indicate the end of transmission of data related to a pixel
- transfer tops (12 tops for each pixel) that flag each of the 12 bits used to code each pixel
- data that indicates if the bit is set to 1 or 0

End of pixel tops are related to $5 + 740 + 9 = 754$ pixels. More precisely, these pixels are (see [figure3.13](#)):

- 5 dark pixels at the beginning of each microband, used by the offset control loop.
- 740 imaging pixels.
- 5 dark pixels at the end of each microband.
- 4 first pixels of the last 17 fictive pixels read, contiguous to the dark pixels.

For the [SDPSS](#), the 10 dark pixels plus the 4 fictive pixels received from the [VEU](#) are called blank pixels.

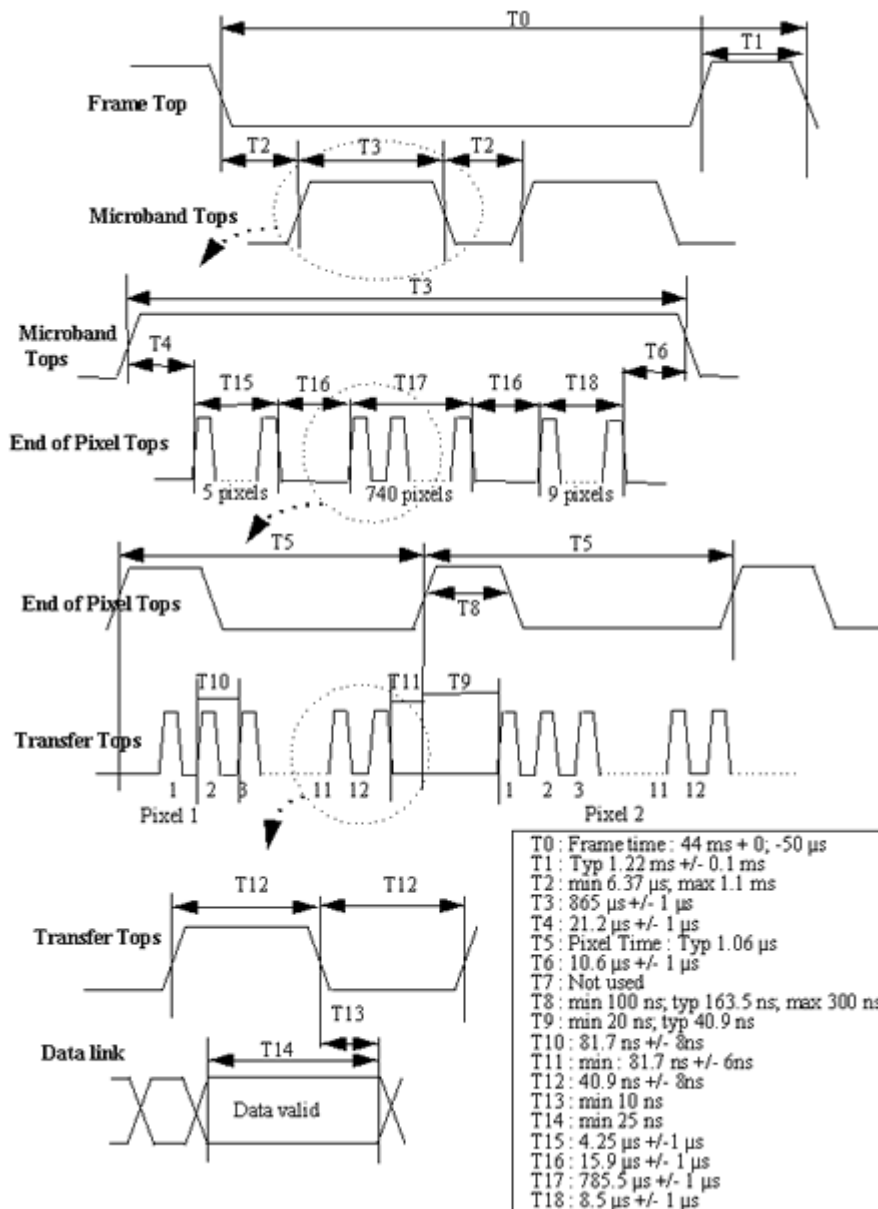

Figure 2.13 - Synchronisation signals between the VEU and the SDPSS.

2.5.3 Video Chains

The global function of each video chain is to:

- receive the video analogue signal (the microbands, shown in [figure3.18](#)) from the [CCD](#).
- perform corrections on this signal.
- convert the analogue signal into a 12 bit digital signal.
- output this digital signal towards the [SDPSS](#) (only the first 5 dark pixels, 740 imaging pixels, 5 last dark pixels and 4 among the last 17 fictive pixels are sent to SDPSS, according to [figure3.13](#)).

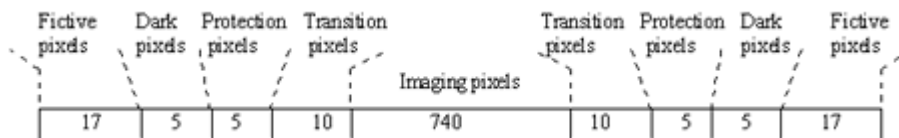

Figure 2.14 - Microband in input of the VEU video chains.

More precisely, each video chain performs (see [figure3.19](#)):

- Reception of the analogue signal from the [CCD](#) and matching of the output impedance of the [DU](#).
- Gain adjustment is an amplification which takes into account the difference in sensitivity of the CCD pixels to different wavelengths, the difference in spectral characteristics of the optical components, the ageing of optical components, and the voltage ranges inside the [VC](#) (see the note 1 below). This gain adjustment is based on the [VEU](#) Gain coefficients presented below.
- Analogue to digital conversion ([ADC](#)): to convert the analogue signal with correlated Double Sampling into 12 bit signals.
- Offset control loop: to compensate for dark current level variation, for each microband (it is made to optimise the dynamic response of the chain). It is possible to enable or to inhibit this offset. For details about the offset control loop, see hereafter.

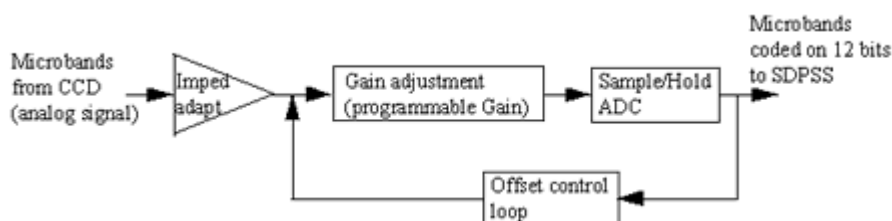

Figure 2.15 - Processing performed by a VEU video chain.

2.5.3.1 VEU Gains

Each [VEU](#) gain is programmable among 12 predefined values. The default values in ROM for VEU gains are given with the associated default spectral bands in [Focal Plane Assembly, Table 3.3](#).

The [VEU](#) gain coefficients are sent from [VEU](#) sequencer RAM to [VCs](#) like the coarse offset coefficients at the beginning of each microband (whatever the enable/inhibit status of the offset control loop). In fact, there are only 16 different values of VEU gains, because the VEU gain has to be the

same for all microbands within a spectral band and for all VC (i.e., 1 value for each of the 16 spectral bands).

2.5.3.2 Offset Control Loop

The coarse offset correction is defined by the value contained in a 12 bit register; this value is converted into an analogue signal and it is applied between the "impedance adaptation" and the gain adjustment step. The content of this register depends on several factors as detailed below:

When the [VEU](#) is switched on, the value put in the register for the coarse offset correction is random. The coarse offset coefficients that are subsequently put into the register depend on the enabling/inhibiting status of the offset correction option, chosen in Measurement, Calibration or Stabilisation [MCMDs](#).

If the offset control loop is inhibited:

At the arriving of each microband in the [VC](#), the 5 coarse offset coefficients stored in [VEU](#) sequencer RAM for this microband are transmitted to the 5 VCs (one coefficient for each VC). Then each coefficient is used for the coarse offset correction of all the pixels of the microband in each VC. This process is applied to all consecutive microbands.

As a result of this process, if the offset control loop is inhibited from the beginning of [VEU](#) switch on, random coefficients (that appear in VEU sequencer RAM when it is switched on) are used to perform coarse offset correction, but then they are kept constant as long as the VEU is left on. These random values are not the same for all microbands, but for a given microband, the random value is constant.

Note: The coarse offset coefficients are not transmitted from the [VCs](#) to the [VEU](#) sequencer RAM at the end of each microband when the offset control loop is inhibited.

When the offset control loop is enabled:

On the basis of the 12 bit digital signal in [VC](#) output, the offset control loop determines the offset correction to apply in feedback between the "impedance adaptation" and the "amplification" step.

When the [VEU](#) is switched on, the coarse offset correction is random.

Then a convergence process begins to determine the appropriate correction, according to the rules given in the following paragraphs for each [VC](#). The target of the convergence process is to determine the coarse offset correction in such a way that the output related to the 5 first dark pixels corresponds to 9.5 LSB on average (i.e., for a large number of microbands, half of the output is 9 LSB and the other half is 10 LSB). For more information about microbands dark pixels, see Spectral bands and CCD.

More precisely, the convergence and correction process is as follows:

At the arriving of a microband in the [VC](#), the coarse offset coefficient stored in [VEU](#) sequencer RAM for this microband is transmitted to the VC: the corresponding correction is applied to all pixels of the microband, including the 5 first dark pixels.

Just after [VEU](#) switch on, at the beginning of the process, the correction is random, so the output corresponding to the 5 first dark pixels is not 9.5 LSB on average.

Then, on the basis of each of 5 first dark pixels of the microband, the offset control loop register is incremented or decremented to converge to the target. The convergence is only performed with the 5 first dark pixels; for the image pixels, the convergence is stopped and the offset correction applied to all image pixels of the microband is constant (it is the correction value as it was in the register at the last of the 5 first dark pixels).

At the end of each microband, the content of the register is sent to the [VEU](#) sequencer RAM and stored as the "coarse offset coefficient" for this microband. Then for the following microbands, all the process previously described begins again, with dedicated coarse offset coefficients.

The time that is needed to reach the convergence coarse offset coefficient for each microband depends on the random value that was in the [VEU](#) sequencer RAM at the VEU switch on. Moreover, the convergence coarse offset for each microband is usually reached after several occurrences of this microband; i.e., several image frames (each microband in the meantime is corrected with a correction between the initial random value and the final convergence value, but it is not possible to know exactly which value, as it is not sent to ground at each occurrence of a microband).

The worst case to reach the convergence value for all microbands after VEU switch on is 36 sec.

Consequently, the convergence has no effect on nominal operation, because it is performed during transition to Stabilisation mode, and this transition is far longer.

2.5.3.3 Coarse offset coefficients in source packets

Coarse offset coefficients are automatically sent from the [VEU](#) to the [ICU](#), and then formatted by the ICU to the [SDPSS](#) for inclusion in the source packets secondary headers, during:

- transitions to Calibration modes.
- transition to a Measurement mode when coming from Stabilisation or calibration modes.

Consequently, between any of these sending events, the coarse offset coefficients put in all source packets are constant: they are the coarse offset coefficients which were in [VEU](#) RAM at the last sending event. This has the following consequence.

If the offset control loop has been inhibited since VEU switch on when a sending event occurs:

[VEU](#) RAM contains random constant coarse offset coefficients, so the source packets contain the same values as in VEU RAM.

If the offset control loop has been enabled since VEU switch on when a sending event occurs:

At a sending event, coarse offset coefficients currently stored in [VEU](#) RAM are transmitted to the [SDPSS](#), and these coefficients are then put in all subsequent source packets.

However, after the sending event, slight adaptation of coarse offset coefficients are continuously done by the offset control loop to compensate for dark current level variation. Consequently, the values put in format do not correspond exactly to the values used for image correction.

2.6 Science Data Processing SubSystem (SDPSS)

The [SDPSS](#) includes 6 digital processing chains ([DPC](#)), consisting of 5 nominal and one in cold redundancy, each being definitely connected to a [VEU](#) video chain ([VC](#)): no reconfiguration is possible between the VEU video chains and SDPSS processing chains.

The [SDPSS](#) also includes a sequencer to control the [DPC](#)s, a main DC/DC converter for power, and a retention DC/DC converter (and a redundant sequencer, main DC/DC converter and retention DC/DC converter, all in cold redundancy).

2.6.1 Sequencer Function

The sequencer controls the [SDPSS](#) (in particular the [DPCs](#)) on the basis of commands and data received from the [ICU](#):

- mode switching commands via [ML16](#)
- data defining the spectral bands, via [ML16](#)
- clock signal via dedicated line, and OBT via [ML16](#)

The [SDPSS](#) also collects information from the [VEU](#) to include in the secondary header of the image formats:

- the [VEU](#) coarse offset coefficients for the 5 "in use" video chains only, received via the [ICU](#) through "coarse parameter" packets
- the blank pixels (14 for each camera module and each of the 16 spectral bands)

2.6.2 DPC Function

The general function of each [DPC](#) is to perform digital corrections on the data (the available corrections in each DPC are displayed in [figure3.20](#)). However, the corrections that are effectively implemented depend on MERIS mode and sub-modes defined in the mode switching [MCMDs](#). DPC processing is only performed in:

- Direct and Averaging mode
- Averaging mode
- Transition to Stabilisation mode
- Transition to Calibration modes

Moreover, the processing performed depends on the sub-mode selected for the mode. More precisely, it is not possible to select a particular process as wanted, but a predefined sequence of processing is automatically performed for each MCMD and sub-mode, as detailed in the following sections.

Each [DPC](#) includes several RAM and ROM sections with a dedicated function. It includes in particular:

- a ROM that contains a number of default values used during the calibrations and observation modes.
- a retention RAM, consisting of an offset RAM and a Gain RAM, in order to keep some particular data in [SDPSS](#) "Retention mode."
- [DPC](#) coefficients area, to store F^{-1} b,k,m; $(A_{i,j})_b$ and K_b coefficients.

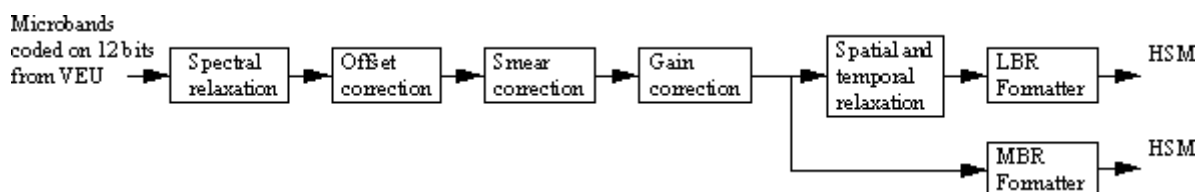

Figure 2.16 - DPC processing.

In the following subsections, the principle of each process is detailed, and then the mode dependency of these processes is given.

2.6.2.1 Spectral Relaxation Principle

The [SDPSS](#) receives microbands coded on 12 bits in input: $X_{l,k,m}$ and $BL_{p,m}$

$X_{l,k,m}$ and $BL_{p,m}$ are respectively the pixel value and the value of blank pixel for:

- pixel k (k varies from 1 to 740)
- microband l (l varies from L_{minb} to L_{maxb})
- camera module m (m varies from 1 to 5)
- blank pixel number p (1 to 14)

with:

L_{minb} (first microband of the spectral band b) and L_{maxb} (last microband of the spectral band b) are programmable parameters sent to the [ICU](#) by the ground, and then from the [ICU](#) to the [SDPSS](#).

Spectral relaxation consists of adding microband pixels to obtain spectral bands pixels $X_{b,k,m}$ for pixel k (k varies from 1 to 740), spectral band b (band varies from 1 to 15) and camera module m (m varies from 1 to 5) according to the formula:

$$X_{b,k,m} = \sum_{l=L_{minb}}^{l=L_{maxb}} X_{l,k,m} \quad \text{eq. 3.1}$$

$$X_{15,k,m} = \sum_{l=L_{min15}}^{l=L_{max15}} X_{l,k,m} \quad \text{eq. 3.2}$$

The number of microbands in one band is given by:

$$L_b = L_{maxb} - L_{minb} + 1 \quad \text{eq. 3.3}$$

2.6.2.2 Offset Correction Principle

Offset correction consists of correcting each pixel (including pixels of the smear band, and excluding blank pixels) of its offset $C_{b,k,m}$ (due to instrument non-uniformities on [CCDs](#), optics, calibration hardware and their ageing). This correction is made according to the formula:

$$\bar{X}_{b,k,m} = X_{b,k,m} - C_{b,k,m} \quad \text{eq. 3.4}$$

$$\bar{X}_{15,k,m} = X_{15,k,m} - C_{15,k,m} \quad \text{eq. 3.5}$$

$C_{b,k,m}$ are offset coefficients for spectral band b , pixel k and camera module m . These coefficients are:

- in the case of "Onboard calibration": calculated by [SDPSS](#) during transition to "Onboard Calibration" and stored onboard in SDPSS offset RAM.
- in the case of "On-Ground calibration": computed on the ground on the basis of data sent to ground via [LBR](#) during the transition to "On-Ground calibration".

2.6.2.3 Smear Correction Principle

Smear correction consists of correcting each pixel of the "smear effect":

When exposed to Earth or Sun light, as the [CCD](#) is continually lit, during the transition of the imaging area into the Storage Zone, CCD elementary spectral lines integrate all other elementary spectral lines signal. This is equivalent to a variable offset on each pixel, depending on the observed signal and the spectral distribution of the signal.

Smearing signal is of the order of magnitude of the [CCD](#) dark current (with an observed [albedo](#) of 0.2 representative of the real observation condition) and has to be corrected.

Only static correction is applied by [SDPSS](#): correction is based on the smear band pixels X_{16,k,m} and smear band blank pixels B_{16,p,m} (available in the image data), and on K_b coefficients (which are sent to MERIS by the ground station).

The correction is according to the formula:

$$\hat{X}_{b,k,m} = \bar{X}_{b,k,m} - (\bar{X}_{16,k,m} \cdot K_b) \quad \text{eq. 3.6}$$

$$\hat{E}_{b,k,m} = \bar{E}_{b,k,m} - (\bar{E}_{16,k,m} \cdot K_b) \quad \text{eq. 3.7}$$

Note: the smear correction is not applied on smear band pixels.

For ocean observation, static correction is sufficient (if the contrast scene is less than 2%) with the IR [CCD](#) elementary spectral lines placed near the smear elementary spectral lines ([albedo](#) ocean have been taken at maximum possible value).

Dynamic correction is possible by using ground processing capabilities; that is why the smear band is sent to ground.

2.6.2.4 Gain Correction Principle

The image data needs to be corrected, pixel by pixel, for gain variation due to instrument components' non-uniformities ([CCDs](#), optics, calibration devices) and their ageing.

Gain correction consists of calculating Full Spatial Resolution pixel values $X_{b,k,m}^{FSR}$:

$$X_{b,k,m}^{FSR} = \hat{X}_{b,k,m} \cdot N_{b,k,m}^{-1} \quad \text{eq. 3.8}$$

$N_{b,k,m}^{-1}$ are Gain coefficients that are calculated:

- in the case of "Onboard calibration": by [SDPSS](#) during transition to "Onboard Calibration" and stored on board in SDPSS offset RAM.
- in the case of "On-Ground calibration": by the ground station on the basis of data sent to ground via [LBR](#) during the transition to "On Ground calibration."

2.6.2.5 Spatial and Temporal Relaxation Principle

The data obtained after spectral relaxation, with or without further offset, smear and gain corrections, is Full Spatial Resolution data. This data can be sent directly to the Medium Bit Rate ([MBR](#)) formatter, and then to the [HSM](#) via the MBR channel. In order to get Reduced Spatial Resolution data, Spatial and Temporal relaxation has to be performed on the Full Spatial Resolution data. The process is described hereafter.

Four consecutive frames on the [along-track](#) direction are stored onboard.

Then Spatial and Temporal relaxation consists of making a weighted summation of 16 pixels (see [figure3.21](#)): on each of the 4 consecutive frames mentioned above, 4 adjacent pixels in the [across-track](#) direction in each frame are taken into account. The pixels are weighted by (A_{i,j})_b parameters. These (A_{i,j})_b parameters are sent from the [ICU](#) to the [VEU](#) through A_{i,j} parameter packets.

In other words, this relaxation consists of calculating Reduced Spatial Resolution pixels $X_{b,i,m}^{RSR}$ (ϕ) of "reduced resolution frame" from Full Spatial Resolution pixels $X_{b,i,m}^{FSR}$ (ϕ) of "full resolution frame" f by:

$$X_{b,i,m}^{RSR}(\phi) = \frac{1}{16} \sum_{f=16-3}^{f=16} \sum_{k=16-3}^{k=16} X_{b,i,m}^{FSR}(f)(A_{i,j}_b) \quad \text{eq. 3.9}$$

$$X_{16,n,m}^{RSR}(\phi) = \frac{1}{16} \sum_{f=4\phi-3}^{f=4\phi} \sum_{k=4n-3}^{k=4n} X_{16,n,m}^{RSR}(f)(A_{i,j,16}) \quad \text{eq. 3.10}$$

where:

$i=k-4n+4$ $j=f-4+4$ b =Spectral band number (1 to 15) m =Camera module number (1 to 5)
 n =number of Reduced Spatial Resolution pixel k =number of Full Spatial Resolution pixels.

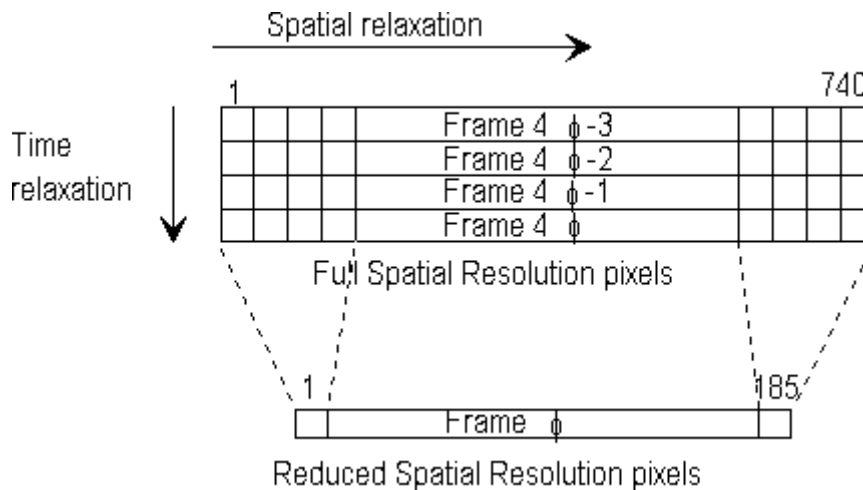

Figure 2.17 - Spatial and time relaxation process.

Note: the $(A_{i,j})_b$ parameters could be used to minimise the aliasing effect on the pixels.

2.6.3 DPC Processing in Measurement and Stabilisation Modes

Each "in use" [DPC](#) performs processing in Measurement and Stabilisation modes (i.e., once the transition to mode is finished), and according to the sub-modes that are defined in the corresponding MCMDs.

[Table 3.7](#), presents:

- the [SDPSS](#) mode, which is used for each MERIS mode and sub-mode.
- the [DPC](#) processes associated with this SDPSS mode.

Table 2.7 - SDPSS processing in Measurement and Stabilisation modes.

MERIS Mode	Sub mode defined	SDPSS	Spectral	Corrections			Spatial & temporal relaxation	Formatting	
				Offset	Smear	Gain		MBR	LBR
	in the mcmd	mode (§ 4)	relaxation						
Direct Averaging &	Full processed	O1	x	x	x	x	x	x	x
	Raw data	O3	x				x	x	x

	Pause	R2							
Averaging	Full processed	O2	x	x	x	x	x		x
	Raw data	O4	x				x		x
	Pause	R2							
	FOV	C3	x						x
Stabilisation	Full processed, FSR	O1	x	x	x	x	x	x	x
	Full processed, RSR	O2	x	x	x	x	x		x
	Raw data, FSR	O3	x				x	x	x
	Raw data, RSR	O4	x				x		x
	Pause	R2							
	FOV	C3	x						x
					: "not performed"	x	: "performed"		

2.6.4 SDPSS Processing in Transition to On Ground Calibration Mode

The processing is only performed in transition to on ground calibration mode (in on ground calibration mode, [SDPSS](#) is in "pause" mode).

Described here is only the type of processing the [SDPSS](#) performs.

In the transition to "on-ground calibration" mode with "Spectral", "Radiometric with diffuser 1" or "Radiometric with diffuser 2" sub-modes, the [SDPSS](#) mode used is the frame averaging mode.

In the transition to "on-ground calibration" mode with "dark calibration" sub-mode, the [SDPSS](#) mode used is dark calibration mode.

2.6.5 MBR / LBR Formatting

[SDPSS](#) multiplexes the 5 [CCD](#) channels to give a global image format to the [HSM](#). This operation is performed:

- by the [LBR](#) formatter, after Spatial and Temporal relaxation for Reduced Spatial Resolution data.

- by the [MBR](#) formatter, with no previous Spatial and Temporal relaxation for Full Spatial Resolution data.

The data is arranged by band order, one band including information from the 5 cameras, that are 5 x 740 pixels.

The instrument provides its measurement data formatted in packets. Formats are provided in a continuous way, in the modes where they are provided.

Each time a packet is sent to the [HSM](#), an End Of Packet (EOP) signal is sent from the formatter (either [LBR](#) or [MBR](#) formatter) to the sequencer, so that the sequencer can check the synchronisation between the reception and sending of science data.

The [SDPSS](#) dates its measurements by use of an internal clock counter synchronised with the one in the [ICU](#).

The auxiliary data (e.g., housekeeping data, datation, mode indication) are inserted into the secondary header field.

2.7 Instrument Control Unit (ICU)

This unit controls MERIS and its functions are:

- Communication with the [PMC](#) via the Digital Bus Unit (DBU).
- Management of the different units and of the functional mode of MERIS after reception of [MCMD](#) from the Polar Platform ([PPF](#)). In particular, the [ICU](#) acquires, checks, and schedules the MCMDs.
- Acquisition and monitoring of MERIS configuration status and of the unit's health.
- Historisation of the successful/unsuccessful execution of the commands, with diagnostic information.
- Thermal regulation of all units except [ICU/DBU](#).
- Calibration mechanism motor control.
- Autonomous control of MERIS when there is no ground link, or in case of internal failure.
- Datation of all onboard events and telemetry packets by an internal clock synchronised by the [PM](#) clock.
- Specific calculations for the configuration of [SDPSS](#).
- Specific calculations in the observation and calibration modes, and storage of calibration data.
- Storage of data patched to SDPSS, and of the dumps from SDPSS.
- Power conversion and distribution for heaters and calibration mechanism.

The function of each internal element is detailed below:

- The computations are performed by the processing core. In particular, the processing core includes a Central Processing Unit (CPU), Memory Management Unit (MMU), Error Detection and Correction (EDAC) and Start-up [PROM](#) chips (only the elements that have a direct relation with some telemetry or telecommand are mentioned here). The [MMU](#) is used to expand addressing capability from 16 bits address to 20 bits address. Start-up PROM contains all specific start-up selftest and monitor software. The [EDAC](#) detects single or double bit errors, in all [CPU](#) memory and start-up PROM (it may detect errors on more bits but it cannot be guaranteed in all cases).

- [CPU](#) computations are based on the Operating System (OS) and the Application Software (ASW).
- The [PROM](#) (i.e., not the start-up PROM, but the external PROM) contains the Operating System (OS), the Application Software (ASW).
- The analogue, temperatures and digital relays status telemetry acquisitions are performed by "Input multiplexers 1 and 2".
- The sending of commands to units (commands to Digital Relay (DR), or [ML16/DS16](#)) is controlled through "High-level and serial data module."
- The [CM](#) motor is controlled via the "CM motor control" module.
- The heaters used for MERIS thermal control are powered via the "Heater controller" module.
- The interface with OBDH and EQSOL/DSL is insured by the BIC module. In particular, this module includes the Remote Bus Interface (RBI)/Application Specific Integrated Circuit (ASIC), that contains all functions for the [RBI](#) low-level protocol. The [RBI ASIC](#) also includes the onboard time counter (32 bits) and the [ICU](#) watchdog. BIC also includes the [ADC](#) that is used for the conversion of all analogue and temperature parameters into digital numbers.

2.8 Power Distribution Unit (PDU)

The PDU can be functionally separated into two independent parts: one piece of equipment for [CM](#) motor powering, and another for all functions except CM motor powering.

2.8.1 Equipment Powering

The [PDU](#) receives the 21/37 V unregulated power from the [PPDU](#) and can distribute it, after protection by fuses, to:

- [SDPSS](#)
- [VEU](#)
- [ICU](#) for heaters
- [DSU](#)

The distribution of power to [SDPSS](#), [VEU](#), [ICU](#) for heaters, and [DSU](#) is controlled by the ICU through relays which make it possible to:

- Power no unit at all (Relay-PDU-N-1 or Relay-PDU-N-2 are Off).
- Power all units except [DSU](#) (Relay-PDU-N-1 and Relay-PDU-N-2 are On; Relay-PDU-N-3 is Off).
- Power all units (Relay-PDU-N-1 and Relay-PDU-N-2 are On; Relay-PDU-N-3 is On).

For the commanding:

- Relay-PDU-N-1 can be switched on by the [ICU](#). It can be switched off only by EQSOL.
- Relay-PDU-N-2 and Relay-PDU-N-3 can be switched on or off by the [ICU](#).

2.8.2 CM Motor Powering

The [PDU](#) is also used to power the [CM](#) motor. For that purpose, it is connected:

- in input, to HSU auxiliary power line, and to power lines from [ICU](#).
- in output, to [CM](#) motor.

The distribution of power to the [CM](#) motor is controlled through Relay-PDU-N-4 and Relay-PDU-N-5, by the PMC. Thanks to these relays, it is possible to connect the CM motor either to an HSU auxiliary power line or to power lines from the [ICU](#).

2.8.3 Telemetry

Telemetry is explained in Annex 3 of the document PO-MA-AER-ME-0005, except for "polarity status" (E4291) and "main line relay" (E4290).

"Polarity status" HK parameter (E4291) is only representative of the polarity of the power line in input of the [PDU](#). If the Relay-PDU-N-1 fails, the "main line relay" HK parameter still indicates "ON" (because no polarity inversion was detected).

"Main line relay" HK parameter is representative of the status of both Relay-PDU-N-1 and Relay-PDU-N-2 . If **both** relays are "ON", the "main line relay" HK parameter indicates "ON;" otherwise it indicates "OFF" (e.g., if any of the 2 relays Relay-PDU-N-1 or Relay-PDU-N-2 is "OFF").

2.9 Digital Bus Unit (DBU)

The DBU interfaces between the [ICUs](#) and the [PPF OBDH](#) bus. It consists of DBU A and DBU B (internal redundancy).

The [DBU](#) A and B connections are given in [figure3.22](#) .

When an [ICU](#) is powered, it automatically provides power to the corresponding part of the [DBU](#). **DBU A** is connected to [ICU](#) **redundant through connector DBU-J05**, and **DBU B** is connected to [ICU](#) **nominal through connector DBU-J06**.

Each part of [DBU](#), when powered, automatically operates with whichever of the 2 [OBDH](#) buses is active.

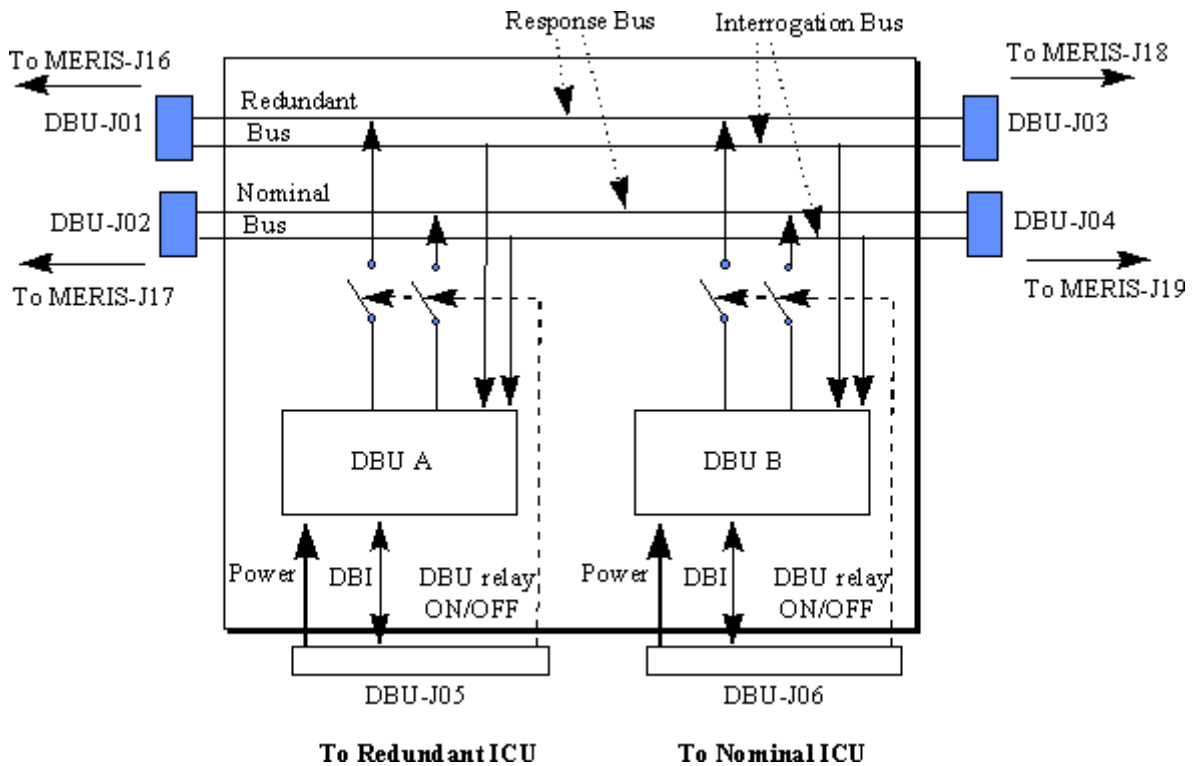

Figure 2.18 - DBU layout.

2.10 Thermal Control

This includes all hardware used for the passive and active thermal control of MERIS.

- Passive control methods
- Heaters and thermistors used for the thermal regulation of units by the [ICU](#).
- Heaters and thermostats used to maintain all the units except [ICU/DBU](#) at non-operational temperatures.

Chapter 3

Internal Data Flow

The optical path and signal processing in MERIS depend on the mode. An overview is detailed in the following 2 figures for the modes involving a science data processing.

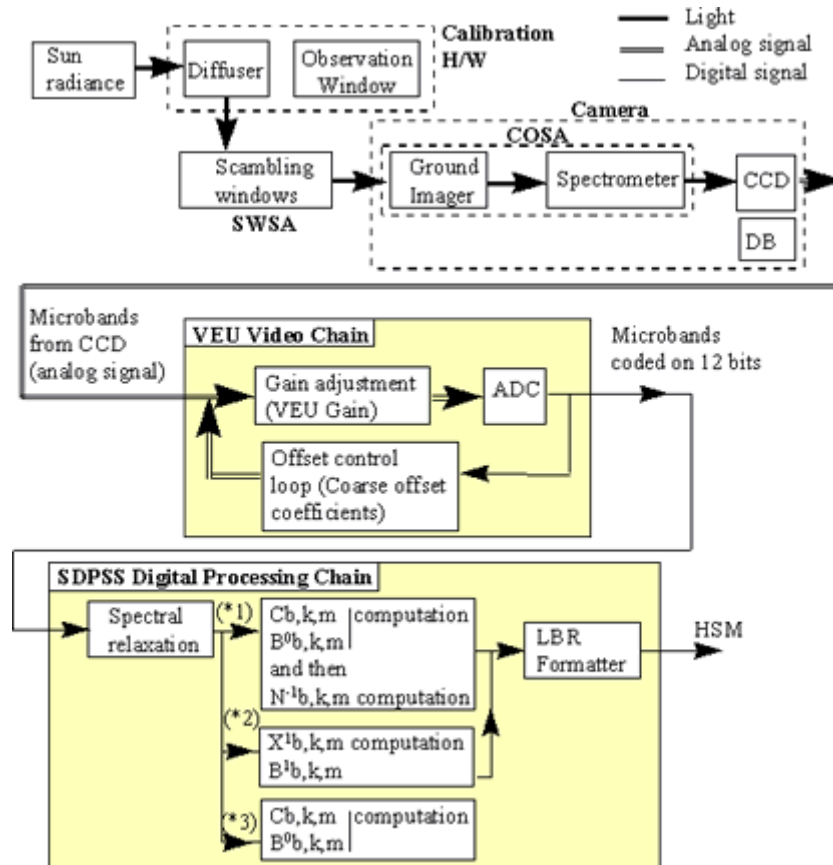

Figure 3.1 - Overview of optical path and signal processing in transition to calibration mode.

(*1): In transition to onboard calibration mode except with "Dark calibration" sub-mode.

(*2): In transition to on-ground calibration mode except with "Dark calibration" sub-mode.

(*3): In transition to onboard or on-ground calibration mode with "Dark calibration" sub-mode.

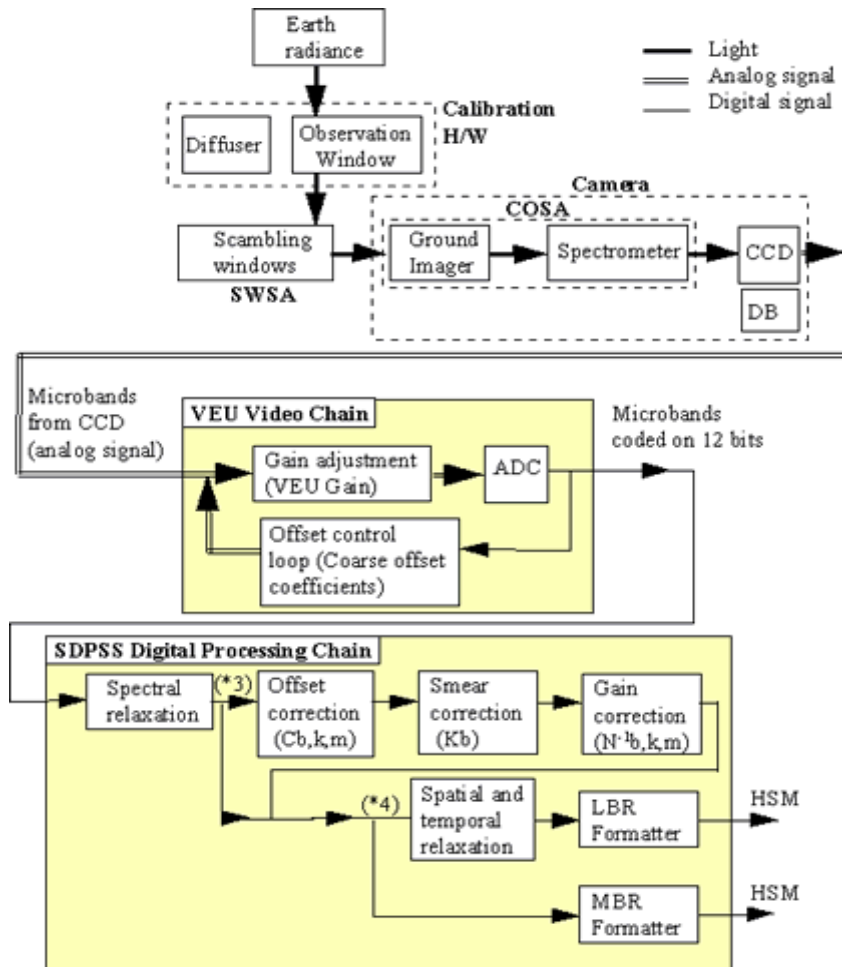

Figure 3.2 - Overview of optical path and signal processing in measurement or stabilisation mode.

(*3): Choice here depends on sub-modes in the measurement or stabilisation mode.

(*4): Same remark as for (*3), but independent of (*3).